

ANTHROT

Your Lawn, Perfected

Genie Series

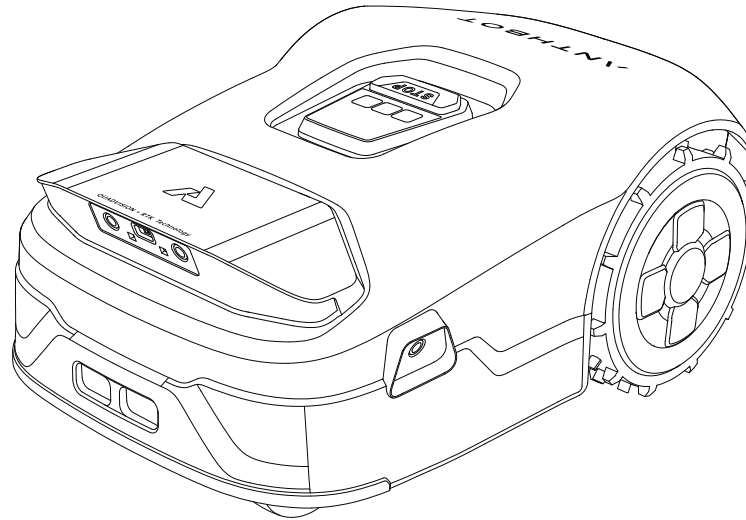

Instruction Manual

Original instructions



Welcome to use the Genie series mower. Please read this manual first to ensure safe and efficient operation.

Note: This product should be operated, and supervised by adults when it is operated by a child.













Welcome

Thank you for choosing the ANTHBOT robotic mower. Please read the instruction below before installing the robot.







Safety Notes

Important! Read all safety warnings and all instructions. Make yourself familiar with the controls and the proper use of the machine. Please keep the instructions safe for later use!

Explanation of symbols on the machine

 	WARNING -Read instruction manual before operating the machine.	 	WARNING -Operate the disabling device before working on or lifting the machine.	 	WARNING -Keep a safe distance from the machine when operating.	 	WARNING -Do not ride on the machine.
	Class III machines.		Electrical appliances must not be disposed of with the domestic waste.				
	The product complies with the applicable European directives and an evaluation method of conformity for these directives was followed.		This device complies with Part 15 of the FCC Rules. Operation is subject to the following two conditions: (1) this device may not cause harmful interference, and (2) this device must accept any interference received, including interference that may cause undesired operation.				

Explanation of symbols on the package

	Recyclable		Fragile		This side up		Keep dry		Stacking layers limit:6		Do not step
---	------------	---	---------	---	--------------	---	----------	--	-------------------------	---	-------------

SAFETY WARNINGS

OPERATION

► Before using

1. Be sure to install and operate the mower and the charging station according to the instructions.
2. Using the mower for purposes other than mowing can bring serious injury. To avoid risks of injuries, please read and understand all the warnings and cautions. Please understand that you can reduce the risk by following the instructions and warnings in this manual, but you cannot eliminate all risk. The operator or user is responsible for accidents or hazards occurring to other people on their property.

3. ANTHBOT has many safety sensors to protect our customers, however, safety risks still exist. Set a mowing time when there are no people or pets on the lawn. Inform the neighbors about the risks for accidents or hazards. When using the mower on a public lawn, or when your lawn is open to your neighbor or street, protect or fence the lawn, or put up a warning sign around the working area that says: WARNING! Automatic lawn mower! Keep away from the machine! Supervise children!
4. DO NOT modify the mower by yourself. Modifications could interfere with mower operations, result in serious injury and/or damage, or void the Limited Warranty.
5. Before working on the mower itself (e. g. maintenance, tool change, etc.) as well as during transport and storage, power off the mower by pressing and holding the on/off button 15s.
6. The manufacturer recommends the user to be 18–70 years old. Be sure to get the necessary training before operating the machine.
7. Never allow children, persons with reduced physical, sensory or mental capabilities or lack of experience and knowledge or people unfamiliar with these instructions to use the machine, local regulations may restrict the age of the operator.

► Before mowing

1. Regularly check that all parts of the mower can function normally.
2. Operate the machine only when the battery compartment is shut with the cover and all the screws in place. This protects the battery against moisture.
3. Keep any supply and/or extension cords away from moving hazardous parts and the working area to avoid damage to the cords which can lead to contact with live parts.
4. Do not to connect a damaged cord to the supply or touch a damaged cord before it is disconnected from the supply for the reason that damaged cords can lead to contact with live parts.
5. For the best mowing results, it is recommended to mow in dry weather. Mowing in the rain can make the grass stick on the product and the mower may slip. DO NOT mow in bad weather, such as heavy rain, thunderstorms or snow.
6. Periodically inspect the area where the machine is to be used and remove all stones, sticks, wires, bones and other foreign objects. The Limited Warranty does not cover damages caused by objects left on the lawn.
7. To avoid possible damage, keep the operating mower at least 1 m (3 ft) away from sprinkler heads. The mower and sprinklers should NOT work simultaneously. Time the mower so that it works at a different time from sprinklers.
8. NEVER allow children to touch the power supply unit, charging station, blades, the battery compartment, or any parts with gaps such as the wheels.
9. To connect the peripherals only to a supply circuit protected by a residual current device (RCD) with a tripping current of not more than 30mA.

► Mowing

1. While operating and as well while approaching the mower, take sufficient precaution to keep balance at all times particularly on slopes and wet grass. Do not stretch yourself too much forwards. Do not operate the mower in a rush.
2. When operating the machine with the hand controls, do not operate the machine barefoot or in open-toed sandals. Always wear sturdy shoes and long pants.

3. During manual control, it is recommended not to exceed speed, always maintain balance, always ensure a firm footing and walk on a slope, and never run while operating the machine or its peripherals.
4. Avoid mowing in bad weather conditions especially when there is a risk of lightning.
5. If the mower vibrates abnormally or makes an abnormal sound or signals an alarm, press the STOP button immediately.
6. DO NOT leave the machine to operate unattended if you know that there are pets, children or people in the vicinity.
7. DO NOT allow children to be in the vicinity or play with the machine when it is operating.
8. DO NOT lift the mower in operation. DO NOT ride on the mower.
9. DO NOT mow on areas with slopes steeper than the maximum incline inside the working area (45%), as well as the boundary (15%).
10. DO NOT touch moving hazardous parts before they have come to a complete stop.

Safe usage

1. DO NOT operate (including charging mode) the mower outside the temperature limits: 3–45°C (37.4–113°F), because low/high temperatures can decrease mower performance and even lead to accidents.
2. DO NOT place anything on the mower or the charging station.
3. It is recommended to conduct regular maintenance of the mower by an adult.
4. Regularly check the warning devices to ensure they are effective. These devices include the voice announcer, the LED light on the charging station, and the screen on the mower.
5. Before charging, please read How to Charge in To set the charging station. Improper use may cause electric shock, overheating, or leakage of corrosive liquid.
6. It is recommended to inspect the mower, charging station, power cord and extension cord every six months for signs of damage or aging. If the mower and charging station are faulty, or the power cord and extension cord are damaged, please do not use the mower and contact the after-sales personnel for after-sales maintenance.

Turn off the mower by pressing and holding the On/Off button

- Before clearing a blockage.
- Before checking, cleaning.
- Before storage.
- If the machine vibrates abnormally (stop and check immediately).
- After striking a foreign object, inspect the machine for damage and get advice on necessary repairs from your after-sales service.
- If the machine starts to vibrate abnormally, and to check for damage before restarting;

Maintenance

1. Please wear gardening gloves when handling or working near the sharp blades.
2. Before working on the charging station or power supply, remove plug from mains.
3. Clean the exterior of the machine. Remove all grass and debris, especially from the blade disc shield.

4. Turn the mower upside down and clean the blade area and the swivel castors regularly. Use a stiff brush or water to remove compacted grass clippings.
5. Make sure all nuts, bolts and screws are tight to ensure safe working with the garden tool.
6. Periodically visually inspect the machine and replace worn or damaged parts for safety.
7. Ensure that only official replacement parts are used.
8. Replace all blades and bolts as a set as required.
9. If it was need to replace the battery, open the battery holder with symbol pointing.

Storage

1. Before storage, power off the mower by press and holding the On/Off button 15s till mower makes a voice announcement and charge its battery to 80% or higher to avoid over-discharge, which will cause permanent damage.
2. Store in a cool and dry place indoors.
3. Keep the mower, charging station and power supply away from heat sources (such as stoves, radiators, etc.) or chemicals.
4. Protect the power supply from moisture and keep it in a well-ventilated place.
5. Store the mower only within a temperature range between -20°C and 60°C . As an example, do not leave the mower in the car in summer.

About battery

1. Do not open the battery compartment. There is a sign pointing out the position of battery, but it is not recommend open it. There is a risk of short-circuiting.
2. Protect the battery against heat(e.g. against continuous intense sunlight), fire, water, and moisture. There is a risk of explosion.
3. Keep any unfitted battery away from paper clips, coins, keys, nails, screws or other small metal objects, that can make a connection from one terminal to another. Shorting the battery terminals together may cause burns or a fire.
4. In case of damage and improper use of the battery pack, vapours may be emitted. Ventilate the area and seek medical help in case of complaints. The vapours can irritate the respiratory system.
5. The battery can be damaged by pointed objects such as nails or screwdrivers or by force applied externally. An internal short circuit can occur and the battery can burn, smoke, explode or overheat.
6. If used incorrectly or if the battery is damaged, flammable liquid may be ejected from the battery. Contact with this liquid should be avoided. If contact accidentally occurs, rinse off with water. If the liquid comes into contact with your eyes, seek additional medical attention. Liquid ejected from the battery may cause irritation or burns.
7. Do not short-circuit the battery. There is a risk of explosion.
8. Use only original battery packs intended specifically for the machine. Use of any other battery packs may create a risk of injury and fire.
9. Ensure the robot has power off before inserting battery. Inserting the battery pack into machines with power on can cause accidents.
10. The ANTHBOT will operate(including charging mode) between 3°C and 45°C . If the battery temperature is outside this range, the APP will display a message and the robot will not leave the charging station. If operating, the robot will return to the charging station or stay in place.
11. Recharge only in the original charging station.This appliance contains batteries that are only replaceable by skilled persons.

Intended use

1. The mower is intended for domestic lawn mowing.
2. Do not operate the mower indoors.
3. Do not use the mower for any other purpose because of the increased risk of accidents and damage to the mower.
4. Never attempt to modify the mower in any way since this may result in accidents or damage to the mower.

Regulatory information



This product and - if applicable - the supplied accessories too are marked with "CE" and comply therefore with the applicable harmonized European standards listed under the Machinery Directive 2006/42/EC, the Radio Equipment Directive 2014/53/EU, and the RoHS Directive 2011/65/EU.



Products marked with this symbol cannot be disposed of as unsorted municipal waste in the European Union. For proper recycling, return this product to your local supplier upon the purchase of equivalent new equipment, or dispose of it at designated collection points.



This symbol means: This product contains a battery that cannot be disposed of as unsorted municipal waste in the European Union. See the product documentation for specific battery information. The battery is marked with this symbol, which may include lettering to indicate cadmium (Cd), lead (Pb), or mercury (Hg). For proper recycling, return the battery to your supplier or to a designated collection point.

Declaration of Conformity

The full text of the DECLARATION OF CONFORMITY is available at the following web link: <https://www.anthbot.com/pages/doc-list>

Recycling and end-of-life disposal

1. DO NOT treat this product as domestic waste. For recycling information, contact your domestic waste service, your municipality, or point of sale.
2. For questions about how to remove the battery, refer to About Battery.
3. WARNING: DO NOT dispose of this product in a landfill, by incineration, or by mixing with household trash. Danger or serious injury can occur because of the electrical components.

What's in the box

Main body

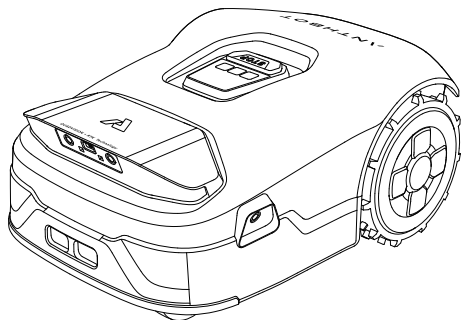

Charging station and installation kit

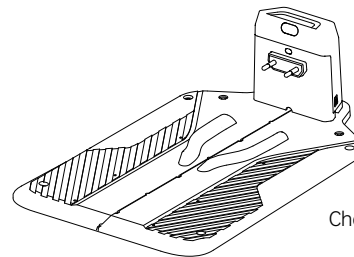

Charging station



x 10

Adapter cable fixing card



x 4

Fixing screw



Charging station adapter



Charging station adapter extension cable

RTK installation kit



RTK reference station

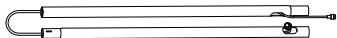

RTK mounting pole

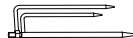

RTK tripod fixing stake

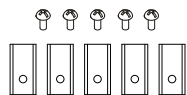

Blade + fixing screw



Hex wrench (6mm)



Screwdriver

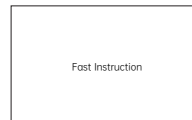

Fast Instruction



Instruction manual

Genie Robotic Mower

TOP VIEW

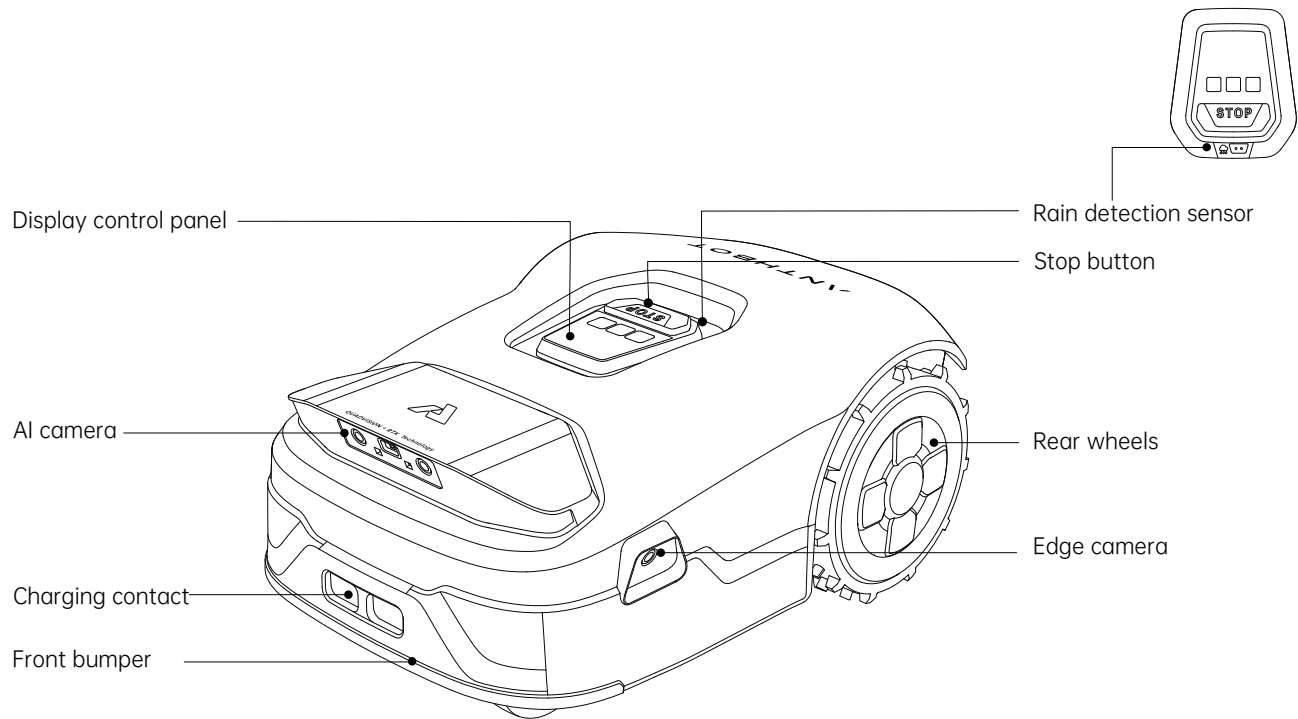

Genie Robotic Mower

BOTTOM VIEW

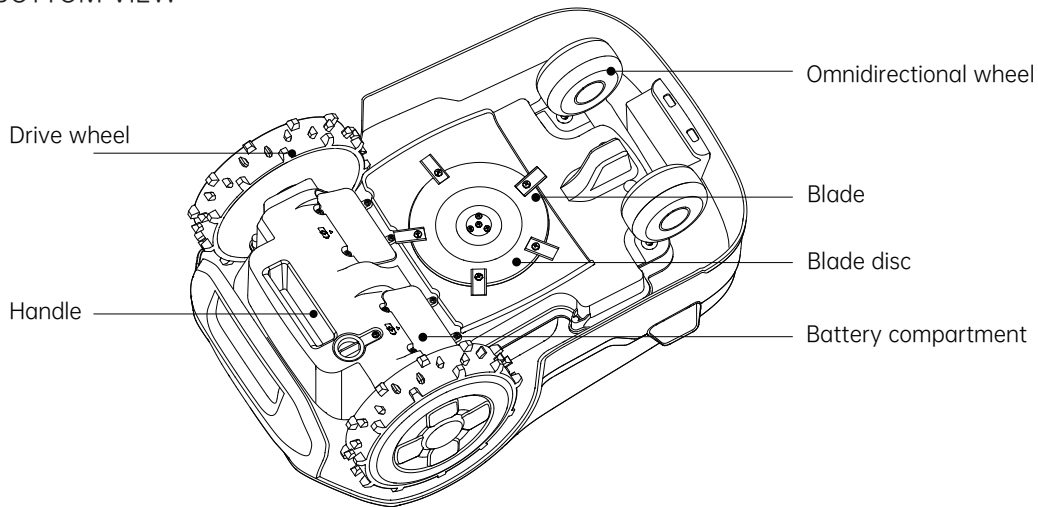

Blade: The blades can rotate freely after being attached to the blade disc. When mowing, the spinning blade disc will generate centrifugal force to keep the blades pointing outside so that the blades can cut grass. When hitting an obstacle, the blade will turn inside.
Blade disc: Blade disc height adjustment through ANTHBOT App.

NOTE: If the mower falls into water, take it out immediately and put the mower right side up to drain it. Never submerge the mower in water, otherwise, the components may be damaged and the Limited Warranty will be voided.

Charging Pile

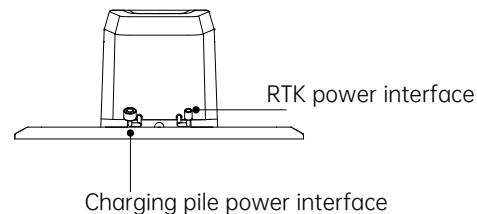
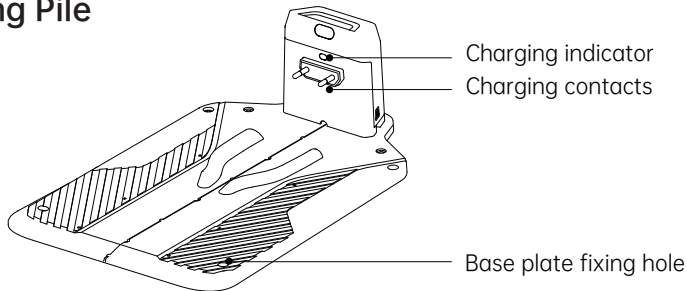

RTK

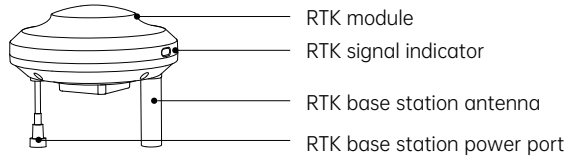

RTK Signal Indicator

Indicator	Status	Description
RTK signal indicator	Red	Powered on
	Flash red	Matching
	Green	RTK signal stabilized
	Flash green	RTK signal instability
	Breath green	Upgrading

NOTE: Assemble the RTK, search for the RTK signal temporarily, find a place with stable signal according to the RTK signal light, and install the RTK. After the installation is completed, the temporary power supply needs to be removed, and the RTK needs to be connected to the charging station power supply.

Main Body Button Description

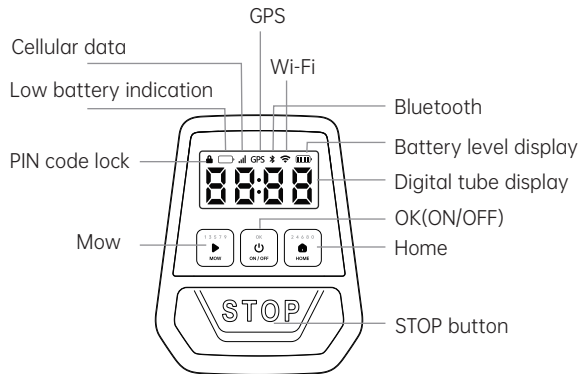

Indicator	Description
PIN code lock	PIN code required for machine operation
Low battery indication	Low device battery
Cellular data	4G signal normal
GPS	Green: the signal is normal flash green: the signal is unstable
Bluetooth	Bluetooth connected
Wi-Fi	Wi-Fi connected
Battery level	Each bar represents 25% battery level, with a full charge at 100%. The last bar flashing indicates low battery, please charge
Digital tube display	PIN code input display Error code display (e.g., E100) Working time display for the current task

Charging Station Installation Environment Requirements

Here are some examples to clearly illustrate correct and incorrect setups:

1. Place the charging station on a flat lawn.
2. Do not install the charging station in the corner of an L-shaped building or a narrow path between two buildings.
3. There should be no obstacles or other objects between the charging station and the docking point.
4. The charging station base plate should not be bent or tilted.

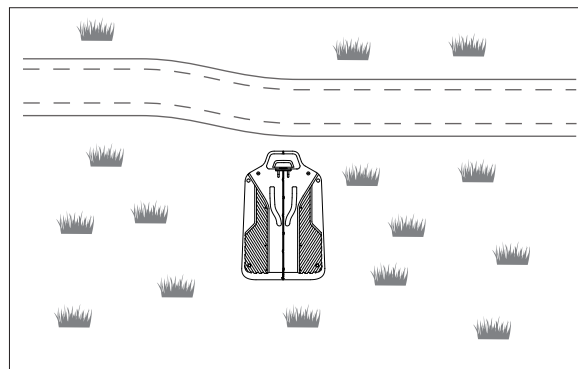
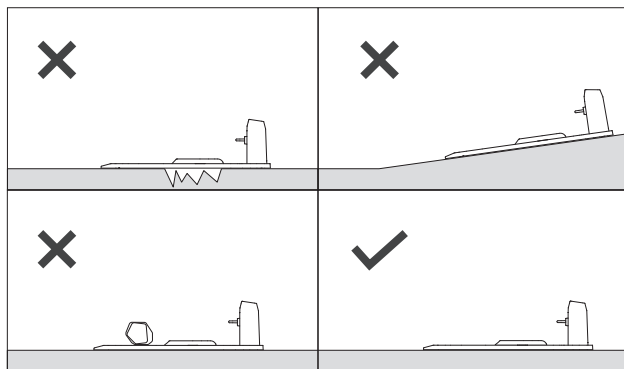

RTK Base Station Installation Environment Requirements

Warning: Before installing RTK, please check whether the RTK signal light and GPS on the host are always green. If they are not on or flashing, please find a suitable open environment with stable signal to install and use.

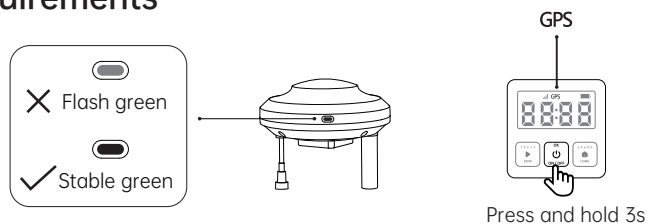

To ensure RTK signal stability, please place the RTK base station in an open area without obstruction. Avoid areas under trees, eaves, or surrounded by multiple buildings that may cause obstructions. The following are recommended usage scenarios for installation:

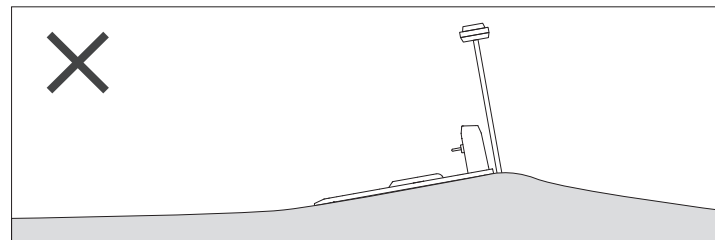
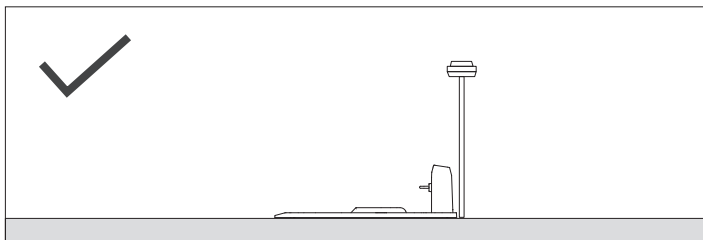
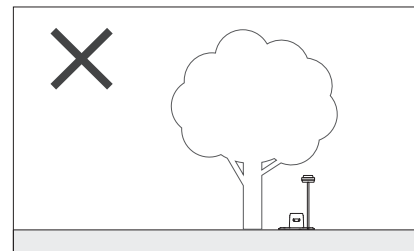
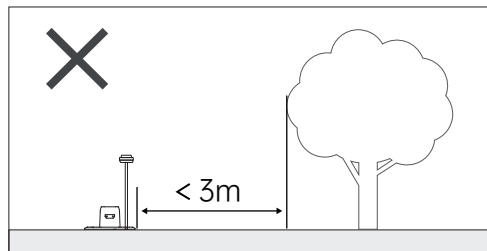
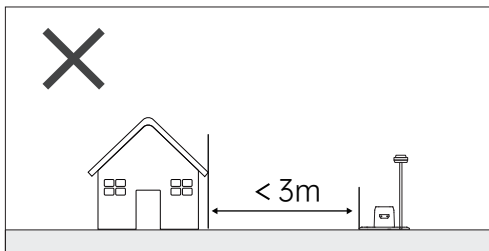
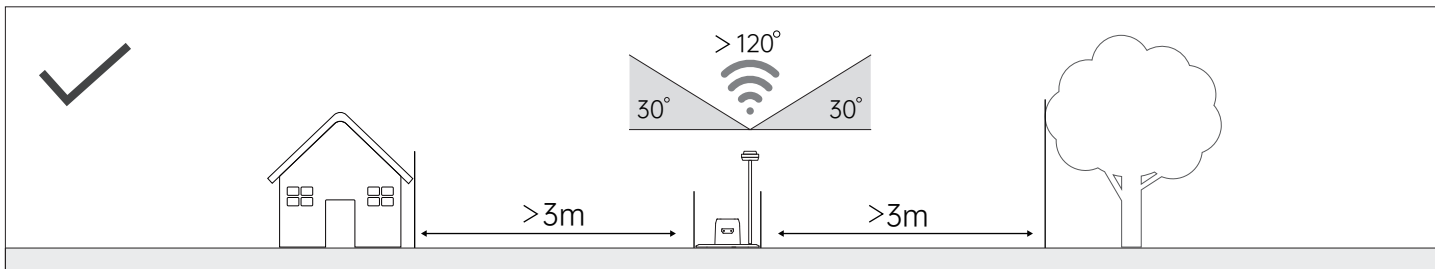

Installation of Charging Station and RTK Base Station

Install the RTK reference station on the mounting pole.
Connect the RTK power port to the power extension cable.
Connect the RTK power extension cable to the charging station power port.

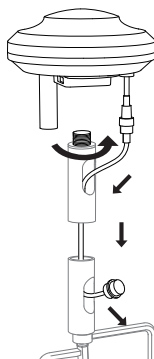

Assemble two mounting poles and the tripod ground stake.
Insert the RTK tripod into the ground and keep it upright.

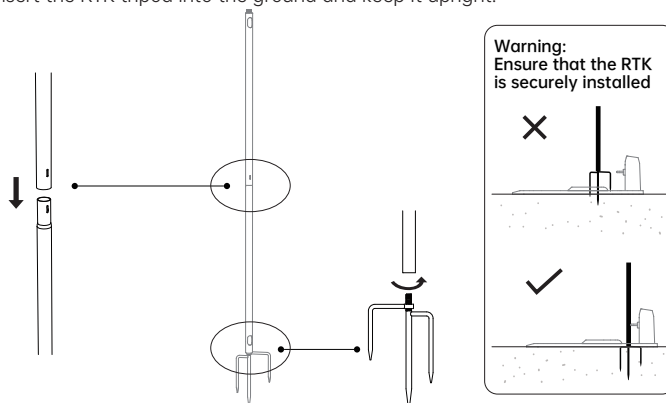

Fix the charging station on a horizontal surface with four fixing screws, ensuring the charging station remains level.

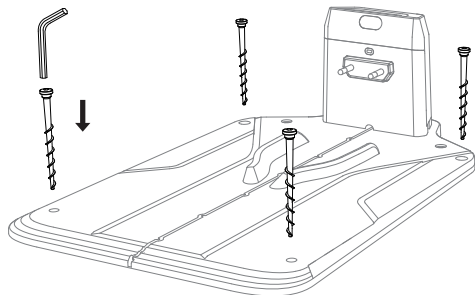

Connect the RTK power extension cable to the charging station power port.

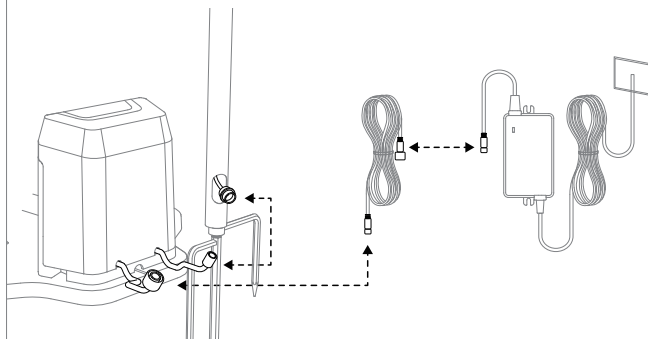

Warning:

1. Make sure the RTK is securely mounted.
2. Create a map for the first time. Please refer to the APP operation guide for creation.
3. After the RTK base station is moved, you need to recreate the map.
4. Move the mower to the charging station and prepare for operation.
5. Please use the APP restricted area function to mark the dangerous area to prevent the device from going astray.
6. When using automatic map creation, please make sure your lawn has clear boundaries.

Clear boundary description:

Physical barriers:

Walls: Walls are the most common border, which can be brick walls, fences, metal fences, etc., usually through sensor detection or visual identification to determine the boundary.

Buildings: Buildings such as houses, huts, garages can also serve as obvious boundaries on the map.

Trees and shrubs: Large trees or dense bushes can serve as borders because they are not usually crossed by lawnmowers.

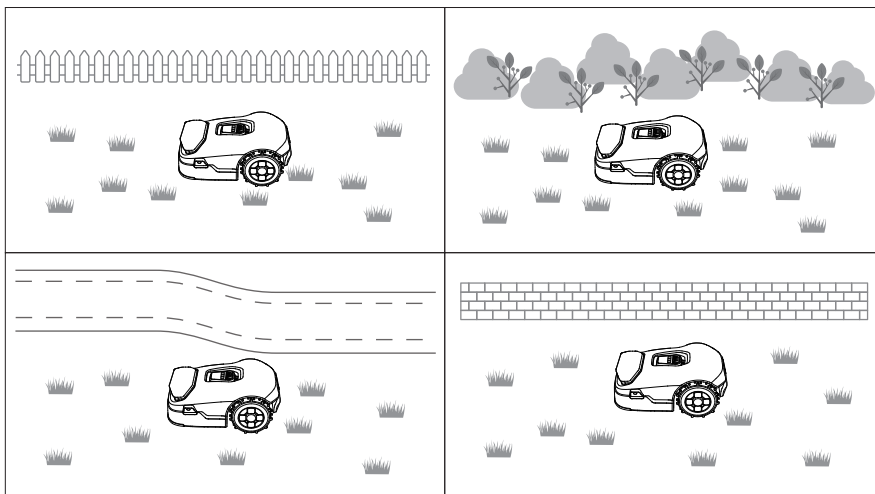

Instructional Guidance for Main Body Buttons

Note: If the mower is in lock status, you must enter the PIN code before operating the mower. The default code is 0000.

🔌 Power on/off

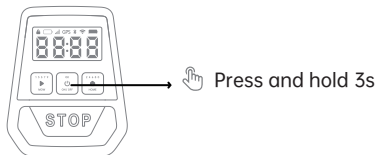

⏹ Stop mower operation

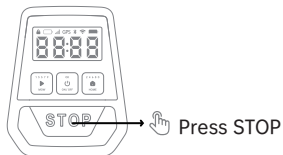

ACC Enter ACC Mapping Mode

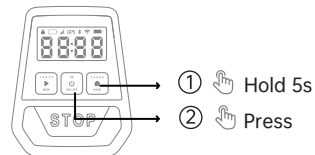

▶ Start global mowing

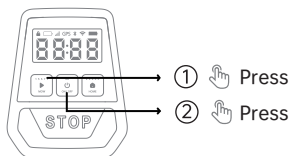

📍 Start area mowing

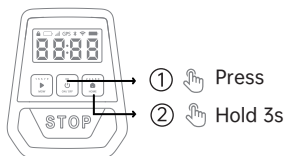

🔒 How to unlock the mower?

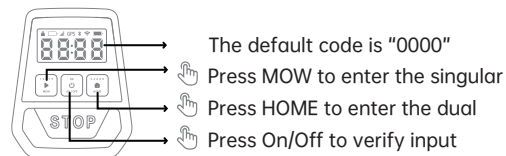

⚡ Mower returns to the charging station

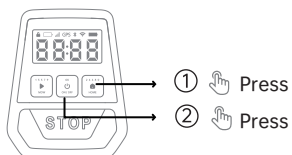

Lora Enter Lora Mode

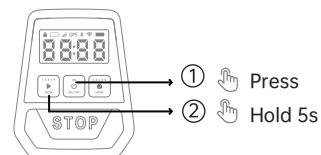

✕ Remove the error reporting operation

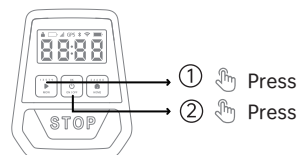

↕ Adjust cutting height

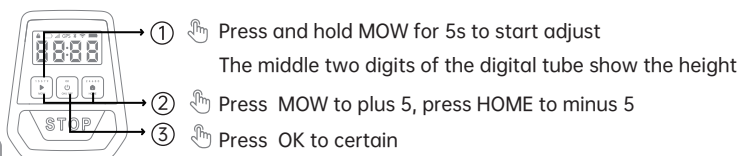

⌚ Restore factory settings

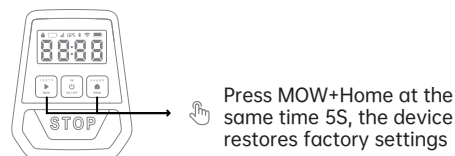

Common Fault Issues

Fault Messages

	Message	Cause	Action
E1XX (communication related)	E101 RTK abnormality	RTK module communication timed out and failed to start	Try restarting. If the error persists, please contact customer service.
	E102 Lora communication abnormality	a. The base station power supply failed to work properly b. There is an obstruction between the host and the RTK base station	a. Please check whether the power supply is normal. Wait about 3 minutes after re-powering on before operation b. Please check whether the host and base station are blocked
	E103 RTK calibration failed	a. The current device is in an obstructed area b. The device calibration action failed to complete	a. Please check whether the device is in the obstructed area and make sure the signal indicator is green. b. Try to restart. If the error persists, please contact customer service
	E104 Lora pairing error	Lora is not paired	Please refer to the detailed instructions (electronic file) for pairing operations.
E2XX (sensor related)	E201 Collision sensor abnormality	Upper shell omnidirectional collision sensor is stuck	Please move the upper shell assembly gently to ensure that it can move normally. If the upper shell moves normally and the error still occurs after trying again, please contact the customer service for processing
	E202 IMU data initialization abnormality	The equipment is initialized abnormally or the machine is not placed on a level surface when started	Please keep the machine level and restart the device. If the error still occurs, please contact customer service
	E203 Rain detection sensor abnormality	The rain detection sensor is dirty or damaged	Try to wipe or clean the rain detection sensor. If the error still occurs, please contact after-sales customer service
	E204 Device suspended	The equipment is lifted or sunk during operation	Please move the device to a safe area and restart
	E205 Blade falls off	a. The blade is not installed firmly enough and is loose, causing it to fall off. b. The blade breaks when it cuts the hard ground.	a. The blade is not installed firmly enough and is loose, causing it to fall off. b. The blade breaks when it cuts the hard ground.

	Message	Cause	Action
E3XX (path-dependent)	E301 Recharge failed	a. There are obstacles around the charging station or tall grass near the charging pile b. The charging electrode is in poor contact c. The power is not enough to support the charging pile d. The charging pile is not powered on e. There is dirt on the lens	a. Please clear the obstacles and tall grass around the charging station and try to recharge again b. Please check whether the charging pole is dirty. If it is dirty, please clean it and try to recharge again c. Please install the charging pile in the middle boundary of the lawn area as much as possible d. Please check whether the power supply of the charging pile is connected to ensure that the power supply is normal e. Please wipe the lens clean to avoid affecting the recognition of the charging pile
	E302 Machine trapped	a. The equipment is stuck in a pit and cannot be rescued b. The equipment is in a high grass area c. The equipment is working in a small corner or complex area, resulting in the equipment being unable to be rescued	a. Please move the device to a safe working environment before starting b. Please trim the tall grass to less than 7cm before cutting c. Confine dangerous and easily trapped scenes to restricted areas
	E303 Ramp start	a. The equipment is started on a slope b. The charging pile is installed at an angle	a. Please move the device to a level surface and restart the device b. Please install the charging station on a level surface
	E304 Reposition failed	RTK signal is poor and the device does not work within the map range	Please put the device on the mobile charging station and restart
	E305 Positioning signal abnormality	a. The device is not within the signal coverage area and is beyond the signal range b. The device is working in a blocked area	a. Make sure the device is working within the map boundary b. Check whether the RTK base station and device are blocked, and do not work on rainy days
	E306 Device out of bounds	a. The device is not within the working area of the map boundary b. The map is offset	a. Please move the device within the map boundary and restart b. Please recreate the map and try to restart
E4XX (motor related)	E400 Left wheel motor abnormality	Left wheel motor stuck or open circuit	Please check if the left wheel motor is stuck. If not, please restart the device. If the error is not eliminated, please contact customer service.
	E410 Right wheel motor abnormality	Right wheel motor stuck or open circuit	Please check if the right wheel motor is stuck. If not, please restart the device. If the error is not eliminated, please contact customer service.
	E420 Lifting motor abnormality	Lifting motor stuck or open circuit	Please check if the lifting motor is stuck. If not, please restart the device. If the error is not eliminated, please contact customer service.

	Message	Cause	Action
E4XX (motor related)	E430 Cutter motor abnormality	Cutter motor stuck or open circuit	Please check if the lifting motor is stuck. If not, please restart the device. If the error is not eliminated, please contact customer service.
E5XX (battery related)	E501 Charging abnormality	Abnormal charging protection	Please recharge the device. If the error persists, please contact customer service.
	E502 Battery temperature too high	Ambient temperature too high	Please ensure that the device is working in a normal working environment. The recommended working temperature of the device is 5 to 40 degrees Celsius.
	E503 Battery temperature too low	Ambient temperature too low	Please ensure that the device is working in a normal working environment. The recommended working temperature of the device is 5 to 40 degrees Celsius.
E6XX (camera related)	E601 Front left camera abnormality	The camera is dirty or blocked (rain, mud, etc.)	Please check whether the lens is dirty or blocked. If it is blocked, please clean it before starting.
	E602 Front right camera abnormality		
	E603 Left camera abnormality		
	E604 Right camera abnormality		
	E605 Front left camera abnormality	Camera module initialization is abnormal	Please restart the device. If the error persists, please contact customer service
	E606 Front right camera abnormality		
	E607 Left camera abnormality		
	E608 Right camera abnormality		
E7XX (other abnormalities)	E700 Triggering Safety Protection	a. The emergency button (STOP) is triggered during operation b. It is lifted during operation	Please press the MOW button first and then the OK button to release the security protection before performing the operation

Product name : ANTHBOT

Type/model:

Genie 600/Genie 1000/Genie 3000/Genie 5000

Sound Data: Measured Sound Power Level LwA : < 70dB(A)

Sound Pressure Level LpA: 55dB(A)

Sound Pressure Uncertainties KpA: 3.0dB(A)

WARNING: Only use the supply unit provided with this appliance.

Genie 600 : DZ048BWL240200U / DZ048BWL240200V / DZ048BWL240200B / DZ048BWL240200S
GM51-240200-1DE / GM51-240200-2DE / GM51-240200-3DE / GM51-240200-4DE

Genie 1000: DZ100CWL280300U / DZ100CWL280300V / DZ100CWL280300B / DZ100CWL280300S
GM95-280300-1DG / GM95-280300-2DG / GM95-280300-3DG / GM95-280300-4DG

Genie 3000/5000: DZ180AWL2800600U / DZ180AWL2800600V / DZ180AWL2800600B / DZ180AWL2800600S
GM259-2800600-1DG / GM259-2800600-2DG / GQ150C-2800600-E3

Download the ANTHBOT App

ANTHBOT APP can be downloaded from Apple APP Store or Google Play. Or scan the QR code to download and install ANTHBOT APP. Follow the APP prompts to add the device.

Precautions: Please make sure that the WIFI network is 2.4G before adding a device.

Download the app



Mower Operation Instructions Preparation

1. Read and understand the safety instructions before operation.
2. The charging station and RTK reference station are correctly installed.
3. Ensure the device is docked at the charging station.
4. Ensure a good Wi-Fi or hotspot signal.
5. Keep your phone's Bluetooth turned on.



User manual

Please scan the QR code to download the electronic manual, which provides you with multi-language instructions and more detailed product introduction.

ANTHBOT

Your Lawn, Perfected

Manufacturer : ANTHBOT (SG) PTE. LTD.

Address : 14 ROBINSON ROAD #02 - 01 FAR EAST FINANCE BUILDING, 048545 SINGAPORE

Customer Service: support@anthbot.com

Official website: <https://www.anthbot.com>