

# Dukkehus

Til både dukker og dyr

Ax2 Bx24 Cx24 Dx2 Ex2 Fx2 x1

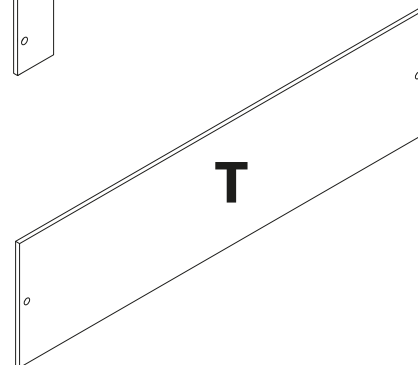
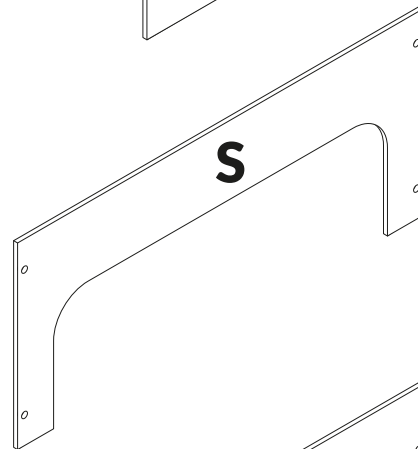
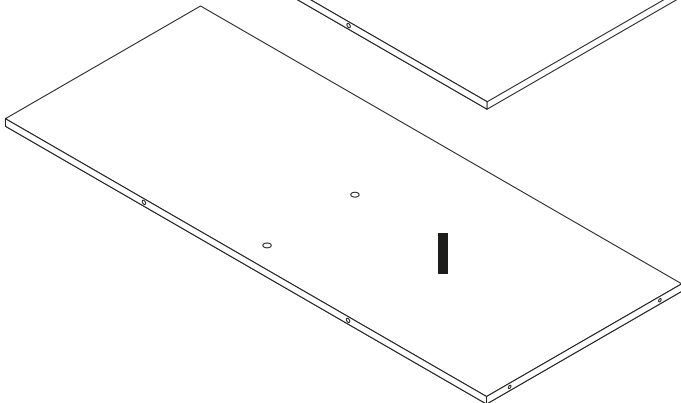
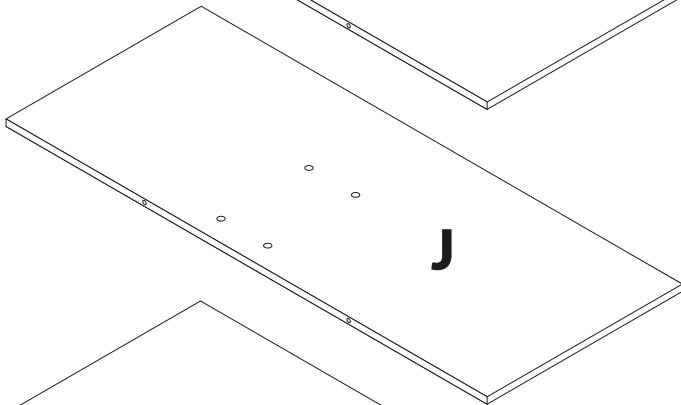
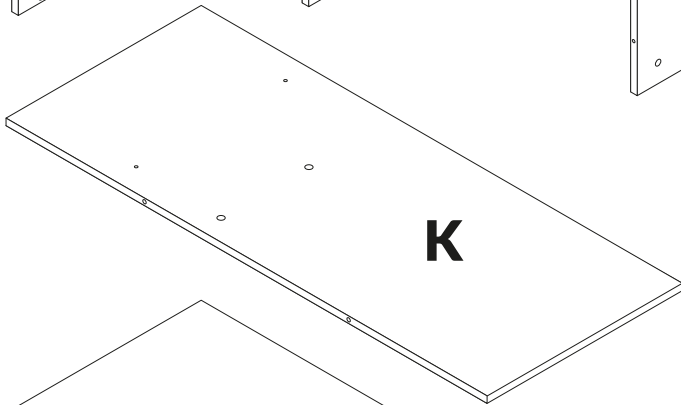
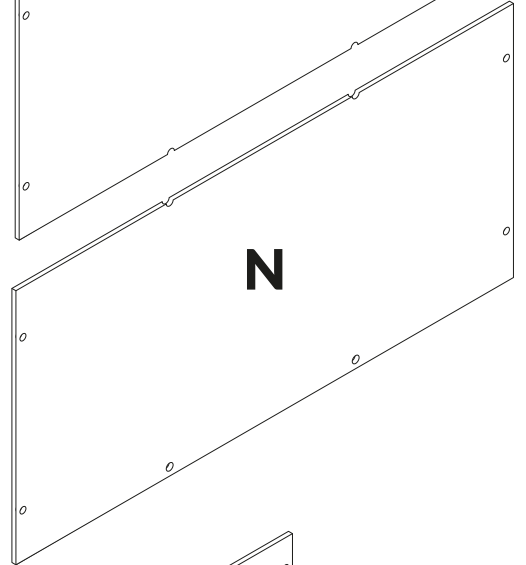
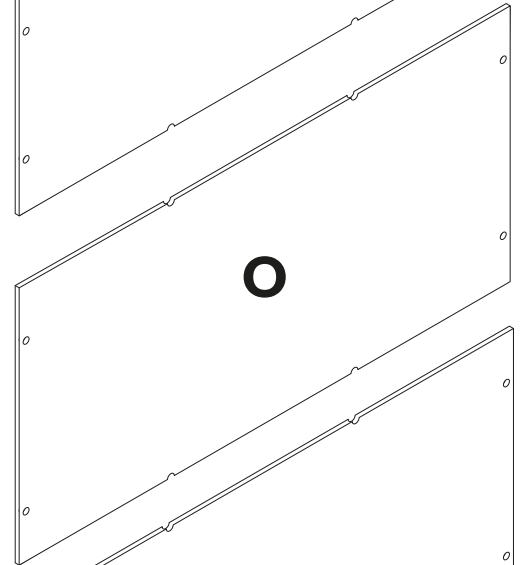
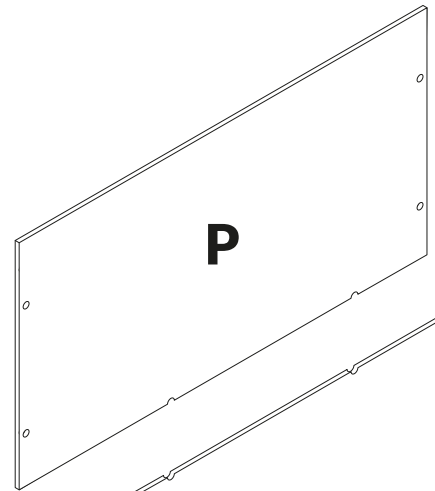
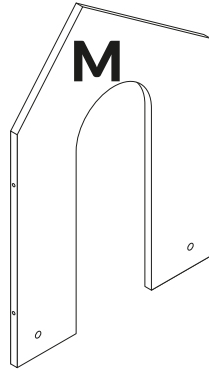
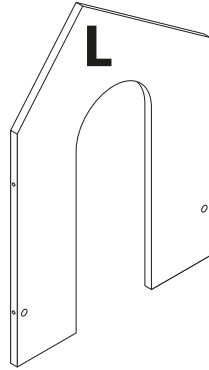
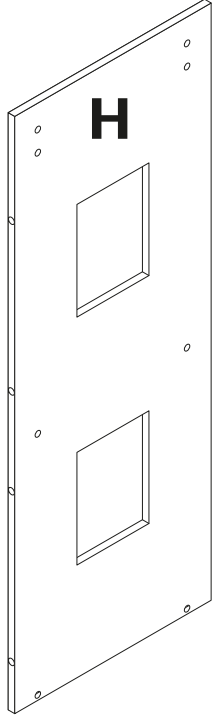
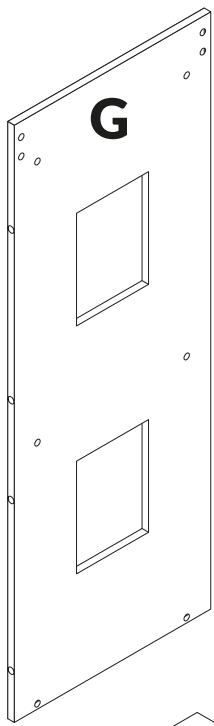
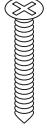

Rx2

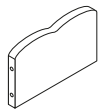

Qx2

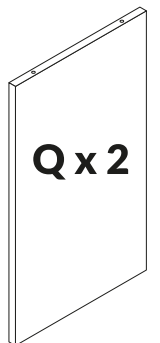

1

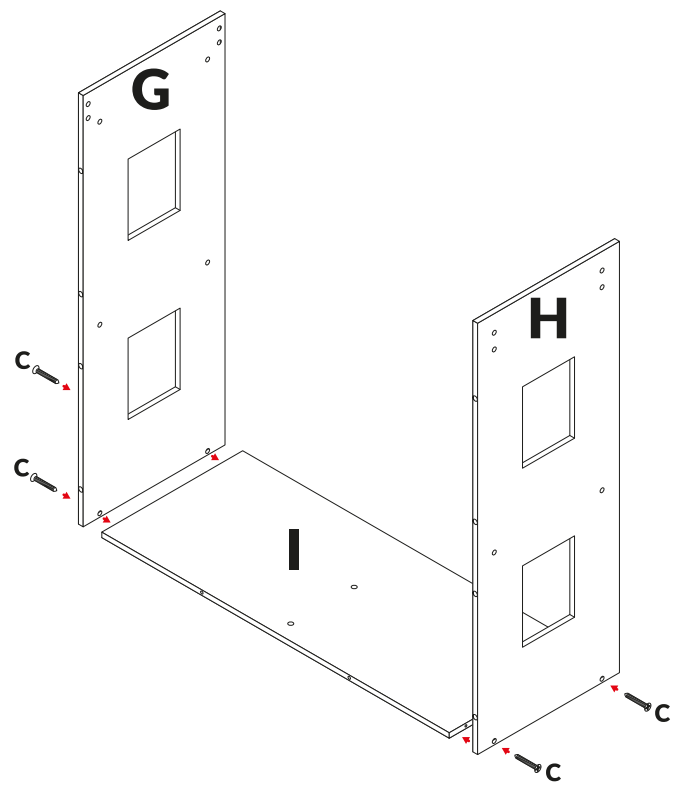

C x 4, G, H, I

2

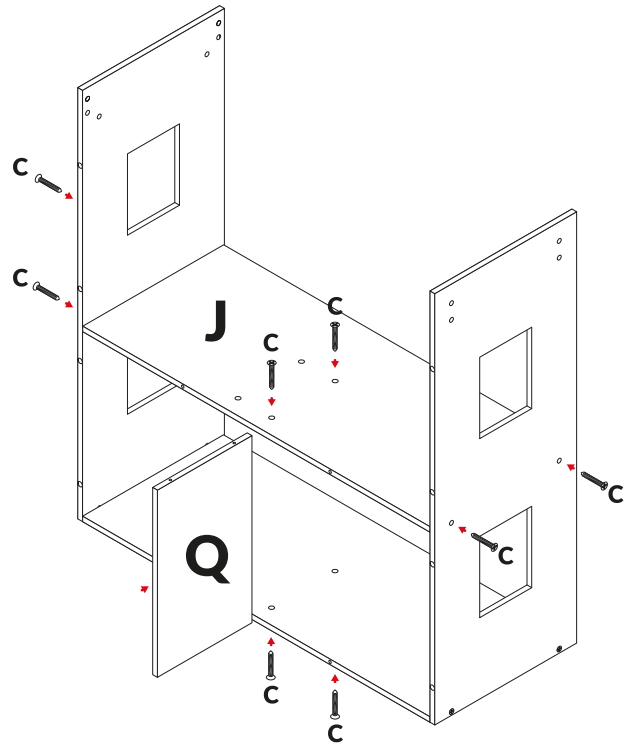

C x 8, J, Q

3

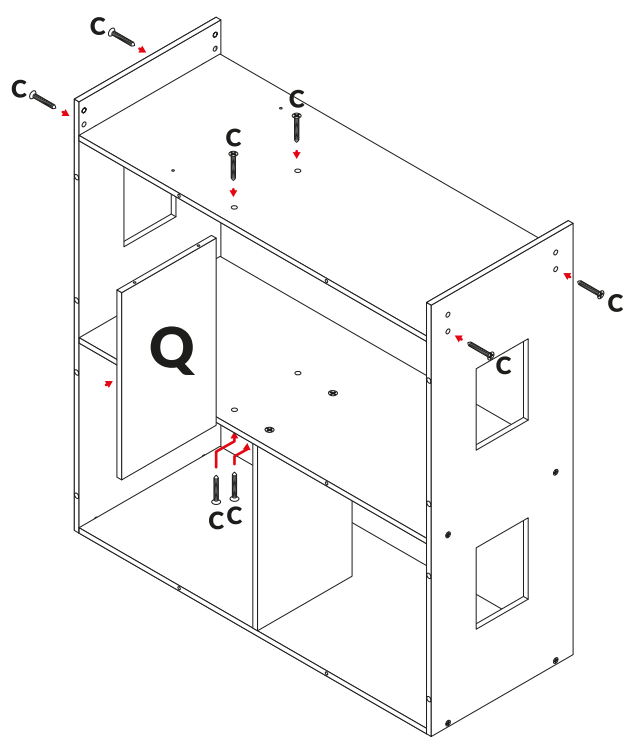

C x 8, Q

4

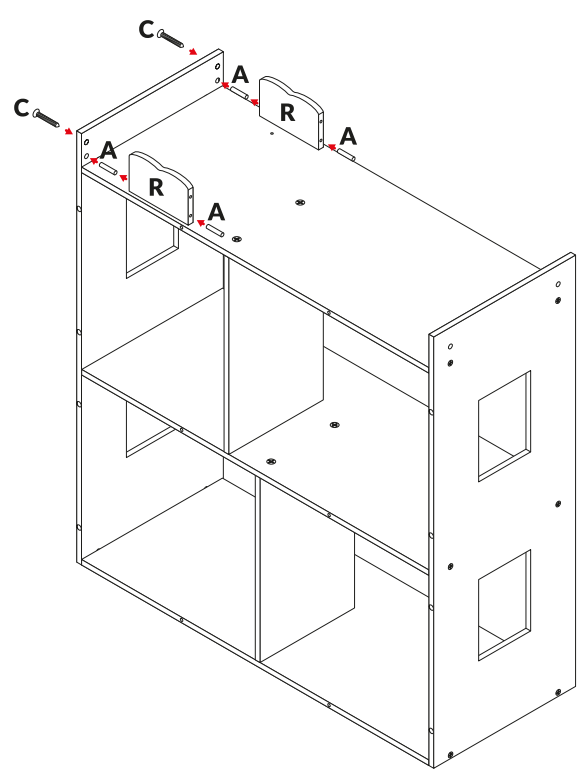

C x 2, A x 4, R x 2

5

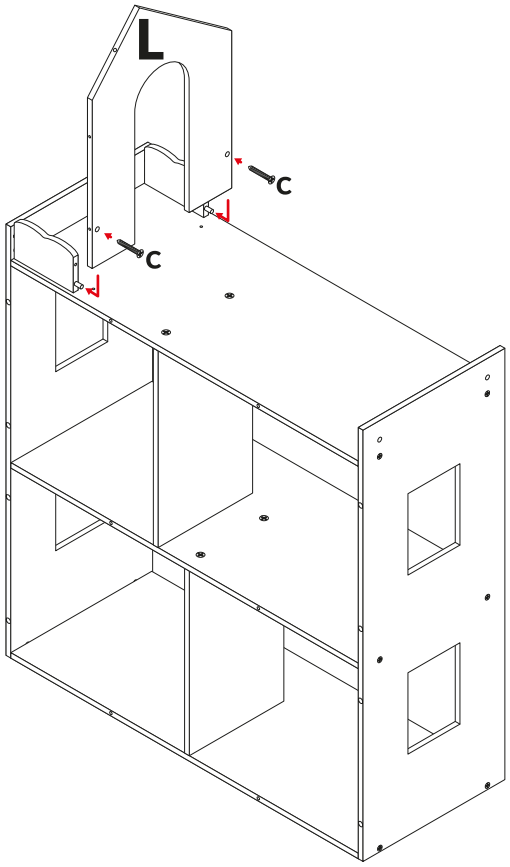

C x 2, L

6

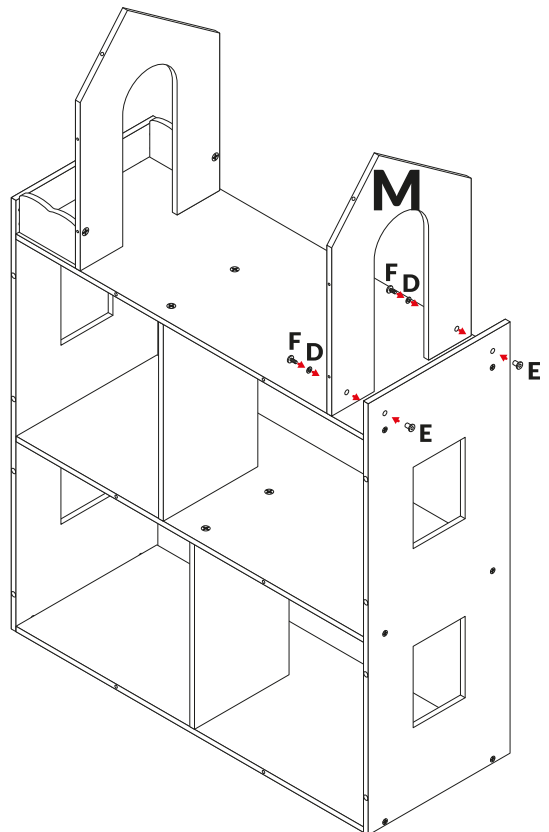

F x 2, D x 2, E x 2, M

7

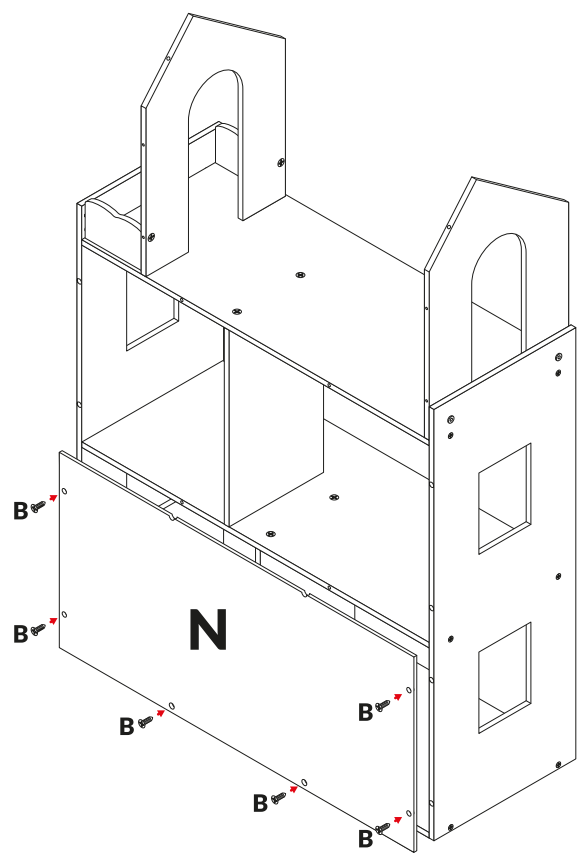

B x 6, N

8

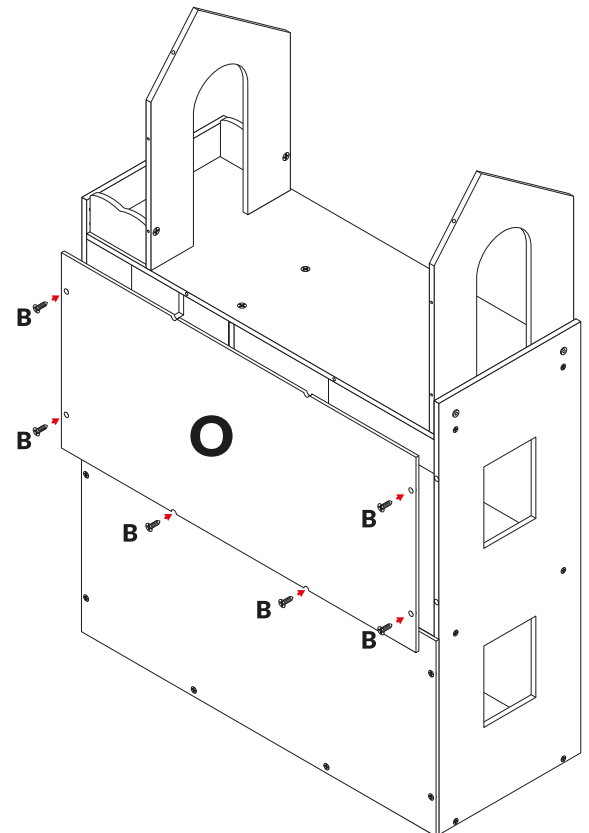

B x 6, O

9

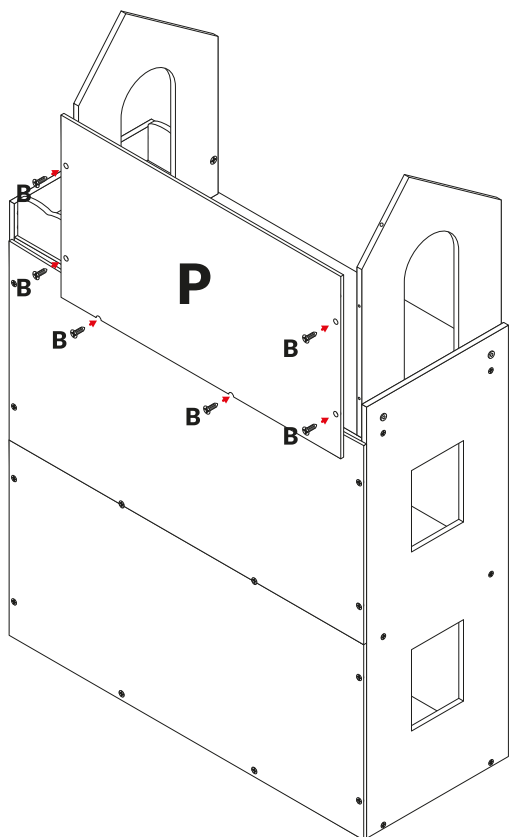

B x 6, P

10

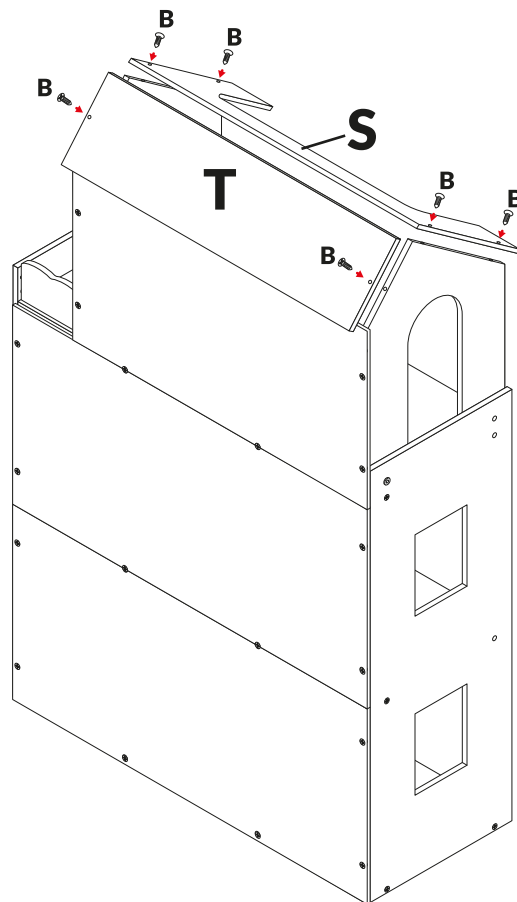

B x 6, T, S

11

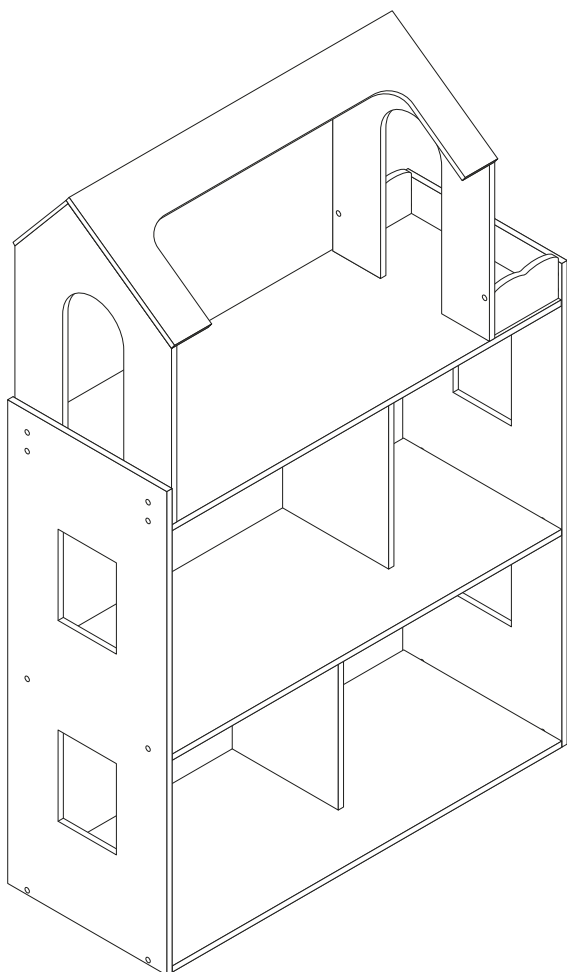

Dukkehuset er nu færdigsamlet. Så er det op til dig og din fantasi, at påsætte de medfølgende klistermærker og skabe dine egne værelser og universer, alt sammen inde i dukkehuset. Så om du er til dukker eller dyr, så er der klistermærker til enhver smag.