



MARMOR SPEEDWAY

GRAVITY RACE BYGGESÆT



ALDER
6+

ADVARSEL:

Kvælningsfare - Ikke egnet for børn under 3 år. Små dele og marmorkuler.

FAO® and FAO Schwarz® names and logos are trademarks or registered trademarks. All rights reserved. www.fao.com

© 2022 MerchSource, LLC. Irvine, CA 92618 For customer support, please call 1-888-987-6533.

KEEP THIS INSTRUCTION MANUAL AS IT CONTAINS IMPORTANT INFORMATION FOR FUTURE REFERENCE.

Due to continuous product improvements, the picture on the manual may differ slightly from the actual product.

Printed in China.

INDHOLD

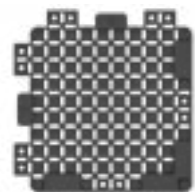

Base Piece
x4



Name Plate
x1

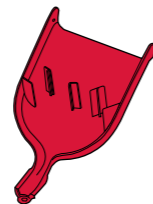

Starting Track
x1



Starting Track Connector
x1

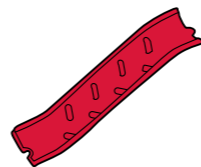

Groove Track B
x2



Arch Track A
x2



Arch Track B
x1



Dual Corner Track A
x6

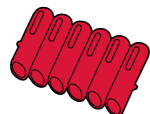

Marble Launcher
x1

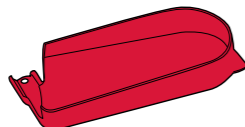

Long Funnel
x1



Funnel
x1

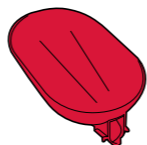

Wide Funnel
x1



Dual Corner Track B
x3

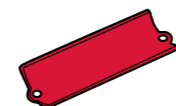

Short Dual Track A
x1

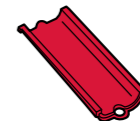

Short Dual Track B
x2



Dual Track A
x2



End Goal Bottom
x1



End Goal Top
x1



Long Track
x2



Track B

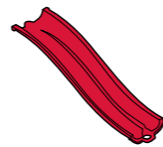

Dual Track B
x1



Corner Track A
x4



Corner Track B
x1



Wide Ring
x13



Curved Track
x1



Tiny Track A
x2



Tiny Track B
x4



Groove Track A
x2



Ring
x9



Connector
x85



Extra Small Post
x31



Small Post
x55



Medium Post
x35



Long Post
x22



Extra Long Post
x21



Sign Holder
x5



Marble
x6



Sign
x5



Post Cap
x19

GLØ-I-MØRKE STYKKER



Følg byggevejledningerne for at tilføje ringene til dit spor. For at tilføje skiltene til din bane skal du installere skiltholderne på stolpehæfterne, ringene eller stik og derefter skubbe skiltene ind i skiltholderne. For den klareste glød skal du lade din bane stå i et stærkt oplyst område i et par timer. Hvis du gør rummet så mørkt som du kan og lader dine øjne justere, vil skæret virke lysere.

SPIL

Ræs med dine kugler i 3 unikke begivenheder! Skriv vinderne ned på de medfølgende kort.

MESTERSKABET

Kamp om mesterskabet!



1. Skriv kuglernes farver i de tomme felter til runde 1 på mesterskabskortet.
2. I ræs 2 konkurrer to kugler med hinanden. Placer 2 kugler på startlinjen og se dem ræse om kamp mod målstregen.
3. Skriv farven på vinderkuglen i hver runde i de tomme felter. Disse går videre til runde 2.
4. Placer de 3 vinderkugler fra runde 1 på startlinjen, og se dem ræse mod målstregen.
5. Den første kugle, der når målstregen, vinder mesterskabet! Skriv vinderen ned, hvorefter sejren kan fejres.

TIDTAGNING

Ræs mod tiden!



1. Brug et stopur eller en stopursapp, og gør dig klar til at tage tid, som skal skrives ned på tidskortet.
2. Sæt kuglen i gang fra startlinjen og start stopuret.
3. Stop stopuret, så snart kuglen når målstregen, og skriv tiden med i det blankt felt til kuglens farve.
4. Hver kugle får 3 forsøg, hvorefter tiden fra de 3 forsøg lægges sammen, så du får en samlet tid for hver kugle.
5. Kuglen, der gjorde det på kortest tid, vinder tidtagningen! Skriv vinderen ned, hvorefter sejren kan fejres.

ELIMINERINGSSPIL

Sidste kugle er ude!



1. Skriv kuglernes farve i de tomme felter for runde 1 på elimineringskortet.
2. Alle kuglerne skal ræse mod målstregen. Sidste kugle er ude!.
3. Skriv farverne på resten af kuglerne ned til næste runde.
4. Bliv ved med at ræse, eliminere og skrive rundens vindere ned.
5. Den sidste kugle, der er tilbage, vinder elimineringsspillet! Skriv vinderen ned, hvorefter sejren kan fejres.

SÅDAN BYGGER DU

Før du går i gang med at bygge, skal du lære hvordan delene sættes sammen. Når du har lært dette, vil du nemt kunne bygge en hel kuglebane!

SÅDAN SÆTTES BUNDENE SAMMEN

Sæt det 4 bundstykker sammen, så du har én stor bund til din kuglebane. Hvert bundstykke har 2 sider med tapper, der stikker ud og 2 sider med riller, der passer til tapperne. Sæt tapperne på et bundstykke mod rillerne på et andet bundstykke, og tryk derefter det ene stykke på det andet stykke, så det sidder ordentligt fast. Drej bundstykkerne efter behov. Gentag dette indtil de 4 stykker er sat sammen. Se vejledningerne til bygning af bunden på efterfølgende sider.

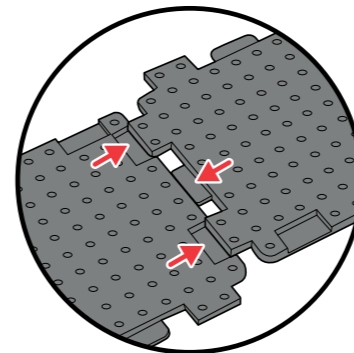

SÅDAN SÆTTES LEDDENE PÅ

Sæt hullerne i leddene mod stængerne, og tryk derefter leddene på stængerne. De andre huller i leddene bruges til, at sætte andre dele sammen.

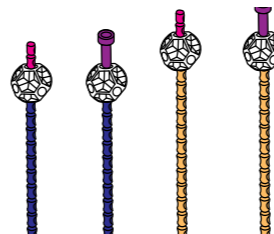

MONTERING AF STÆNGERNE

Stængerne sættes på bunden ved at sætte enderne i hullerne foroven på bunden. Tryk stængerne ordentligt i. Følg byggevejledningerne, så du ved hvor hver stang skal sidde.

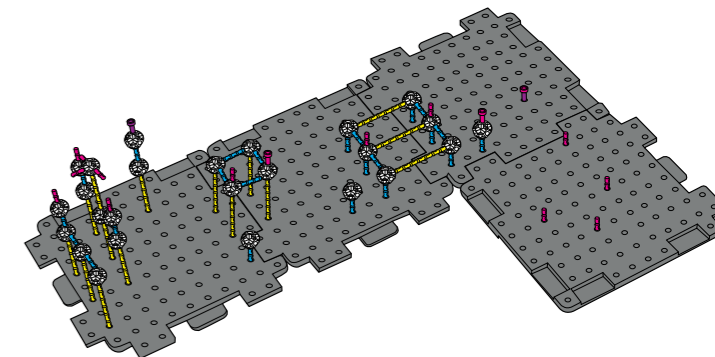

SÅDAN SÆTTES BANERNE SAMMEN

Når banestykkerne sættes sammen, skal du starte med enden med pinden på hvert banestykke. Hullet på modsatte enden af banestykket sættes på stængerne med dækslerne. Pinden på det næste banestykke trykkes ind i hullet på banestykket, der allerede er sat på.

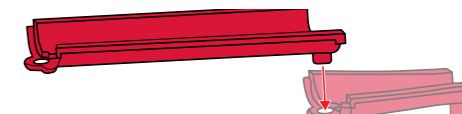

VEJLEDNING TIL BUNDEN

Dette er din vejledning, når du sætter delene sammen. Brug de medfølgende vejledning til at lave dit layout. Tag også et billede, så du hurtigt kan referere til det!

BYGGER 1

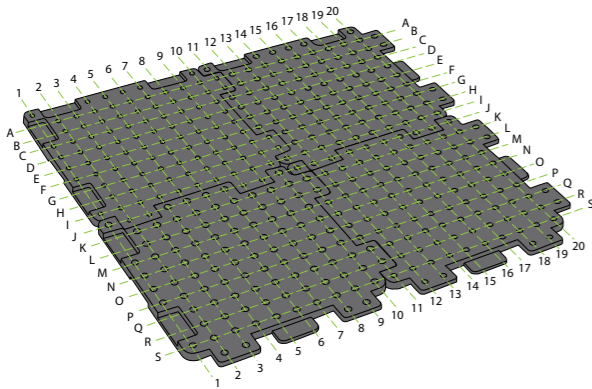

BYGGER 2

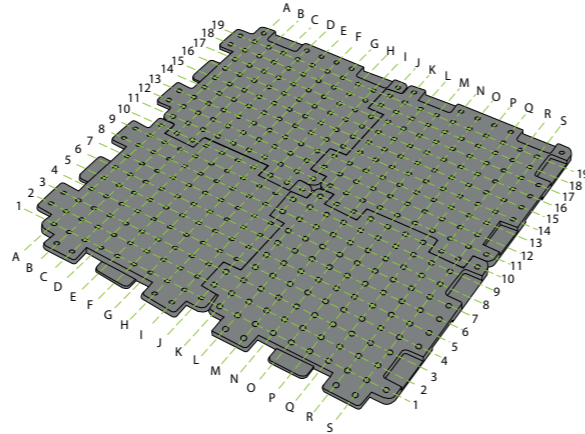

BYGGER 3

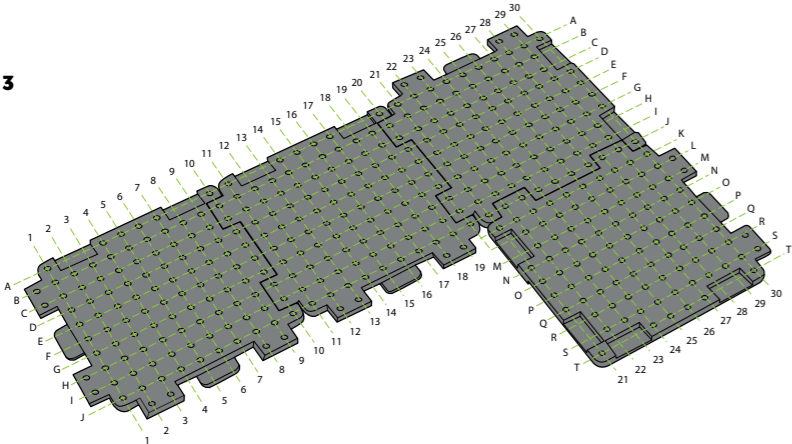

BYGGER 1

TRIN 1

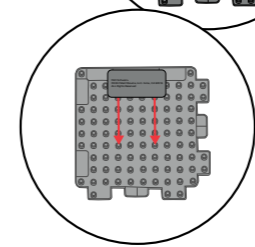
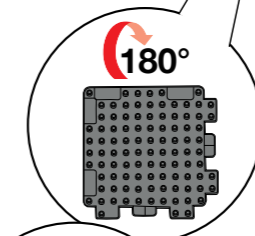
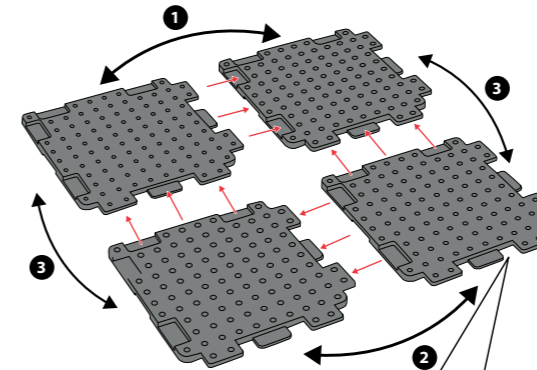

TRIN 2

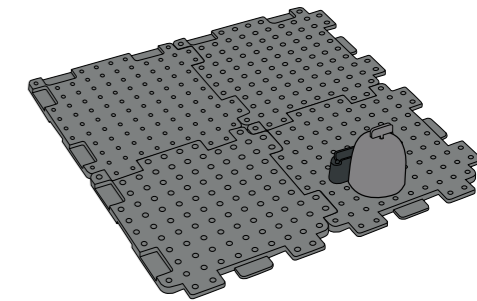
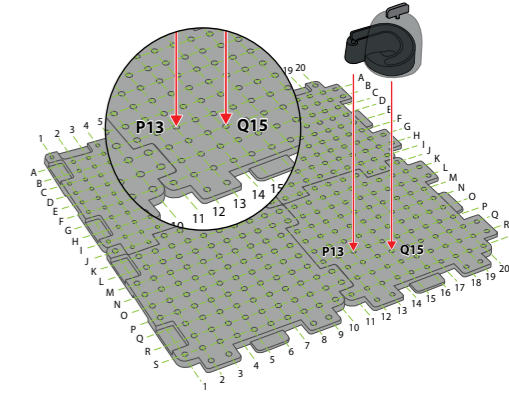
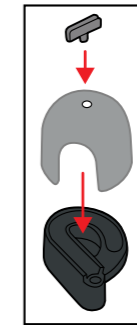
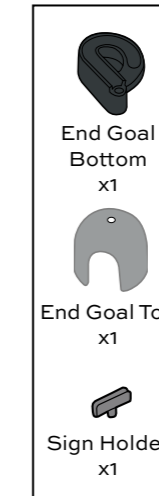

BYGGER 1

TRIN 3

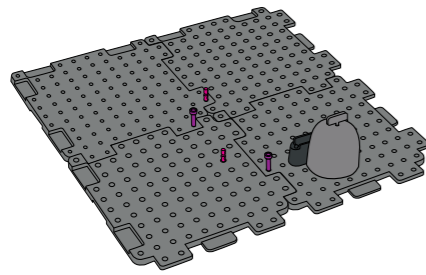
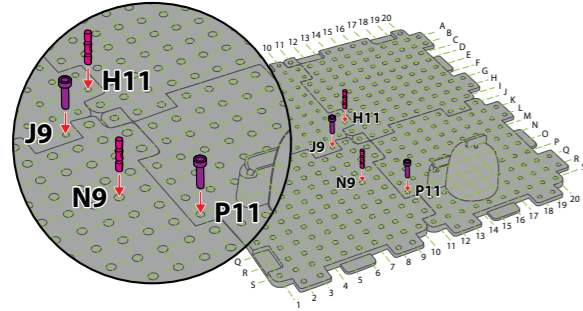
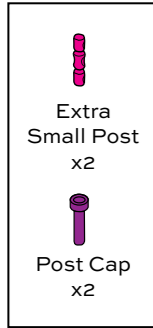

TRIN 4

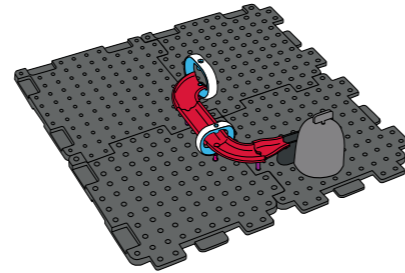
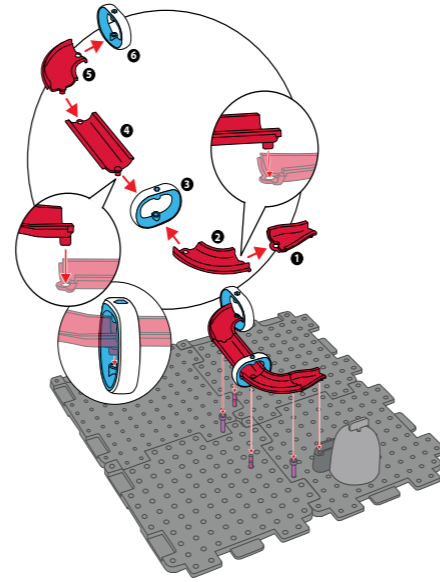
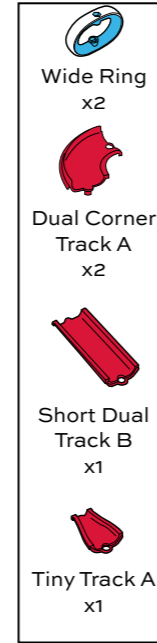

BYGGER 1

TRIN 5

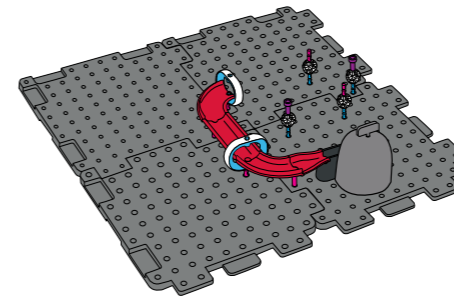
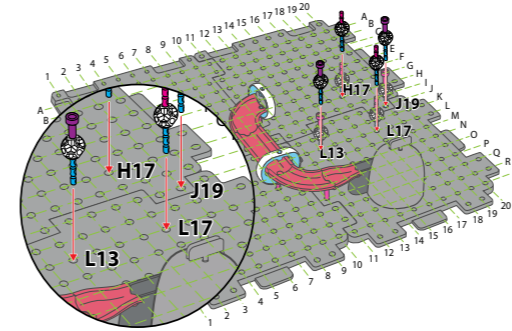
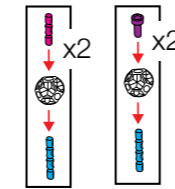
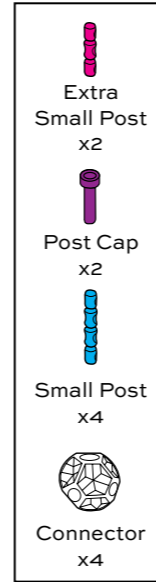



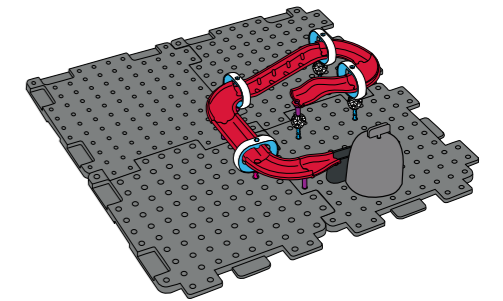
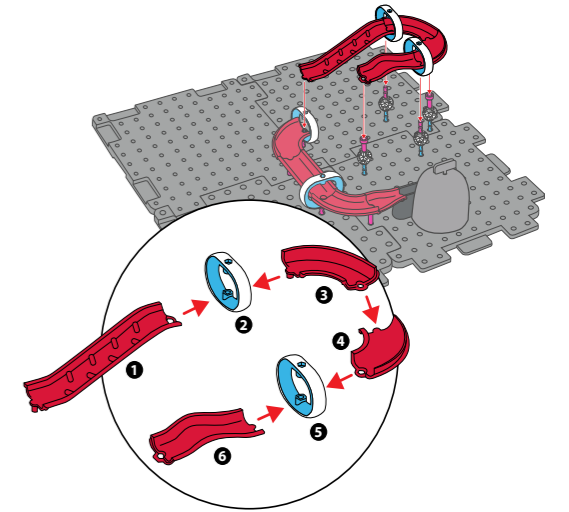
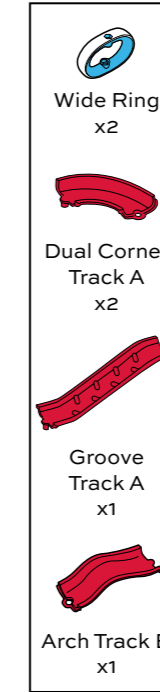



TRIN 6



BYGGER 1





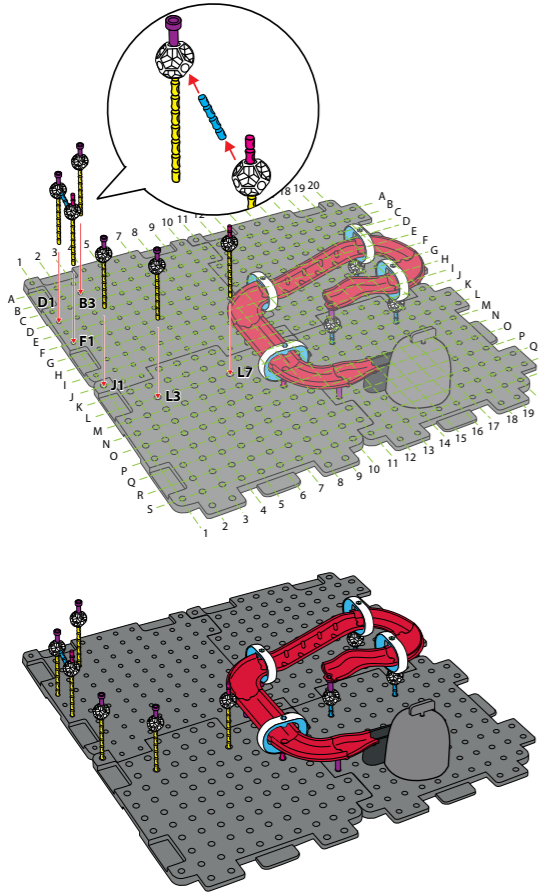

TRIN 7



-  Wide Ring
x2
-  Arch Track B
x1
-  Dual Track A
x1
-  Dual Corner Track B
x2

-  x2
-  x4



TRIN 8



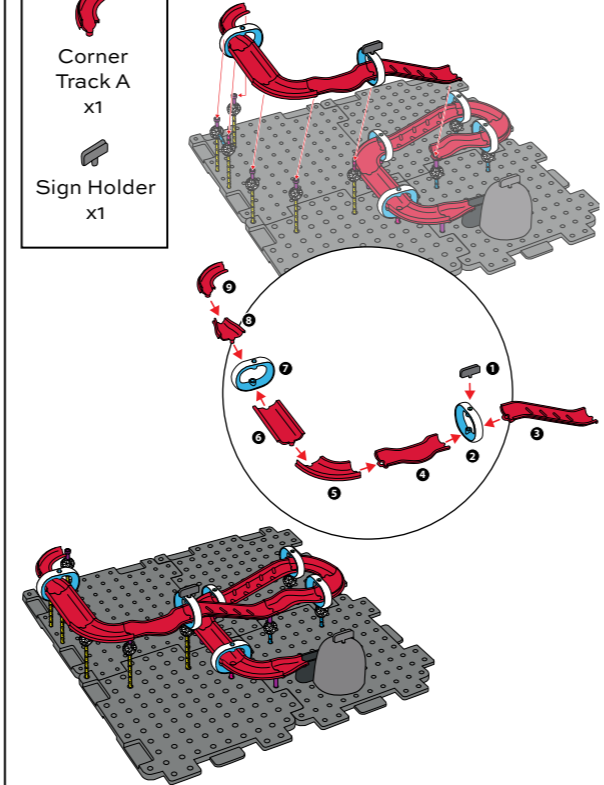

-  Wide Ring
x2
-  Tiny Track B
x1
-  Arch Track A
x1
-  Groove Track A
x1
-  Short Dual Track B
x1
-  Dual Corner Track A
x1



-  Corner Track A
x1
-  Sign Holder
x1



BYGGER 1

TRIN 9

-  Post Cap
x2
-  Small Post
x1
-  Medium Post
x3
-  Long Post
x8
-  Connector
x8

-  x1
-  x4
-  x1

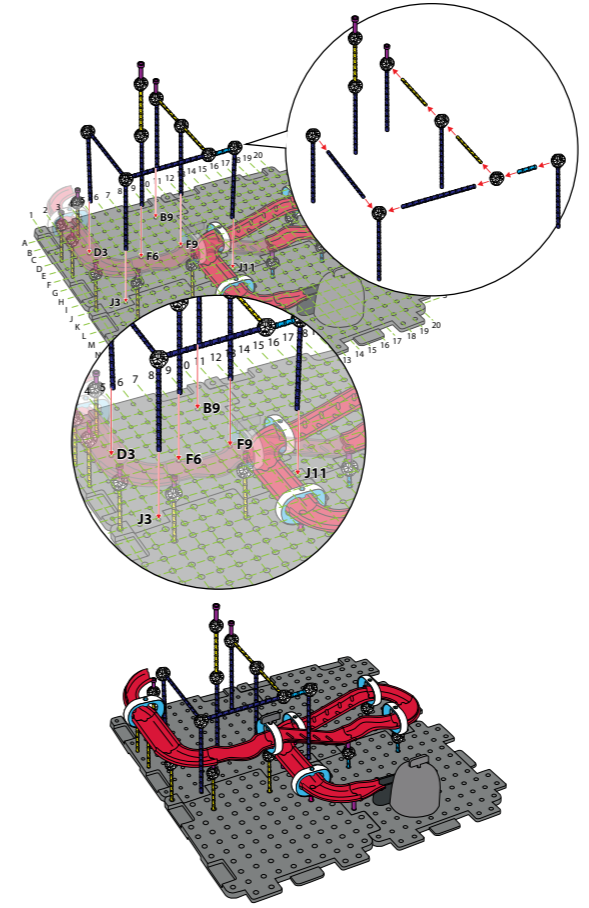

TRIN 10

-  Track B
x1

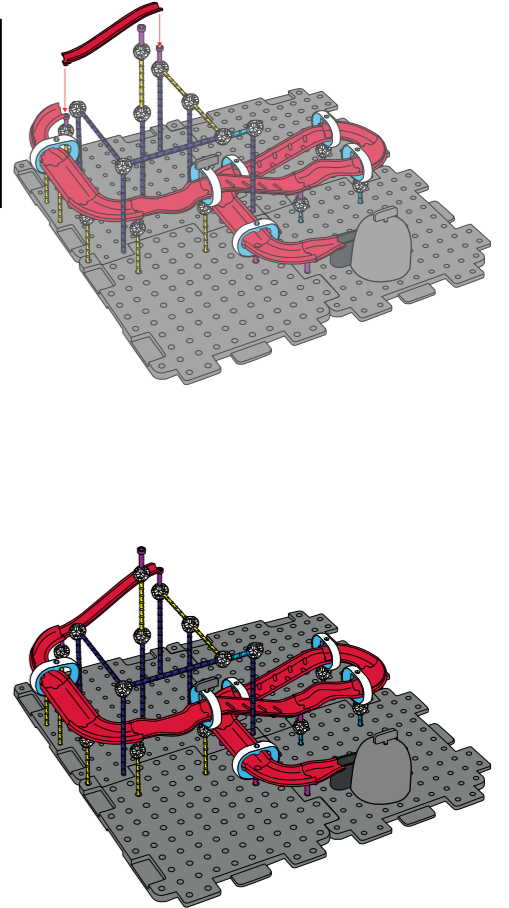

BYGGER 1

TRIN 11

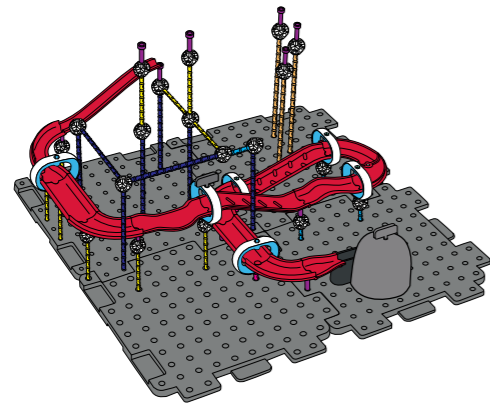
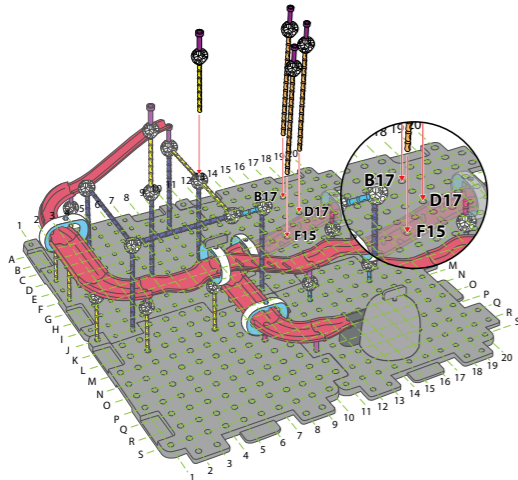
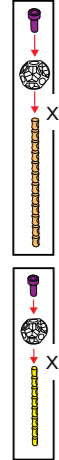
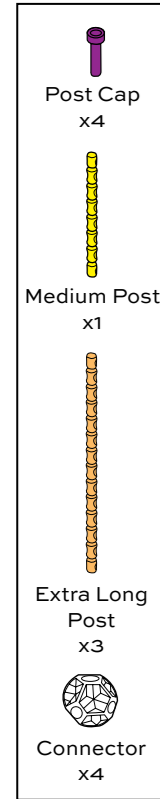

TRIN 12

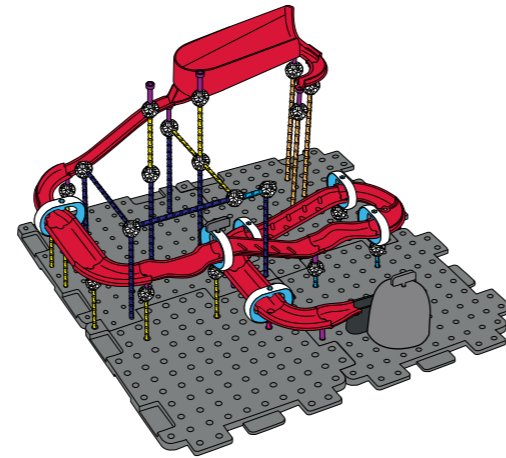
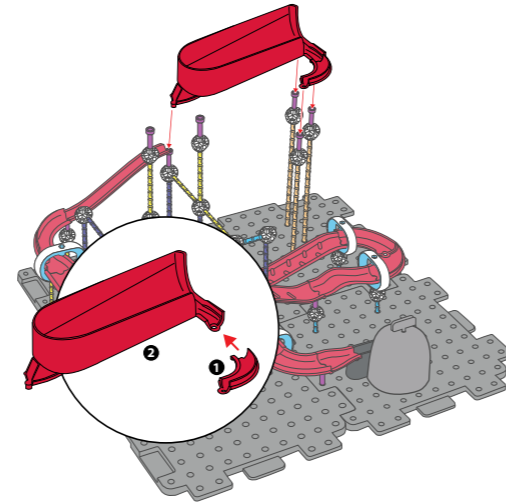
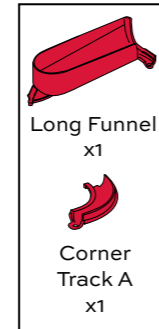

BYGGER 1

TRIN 13

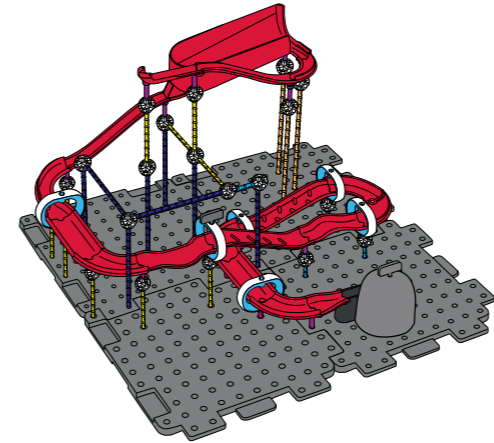
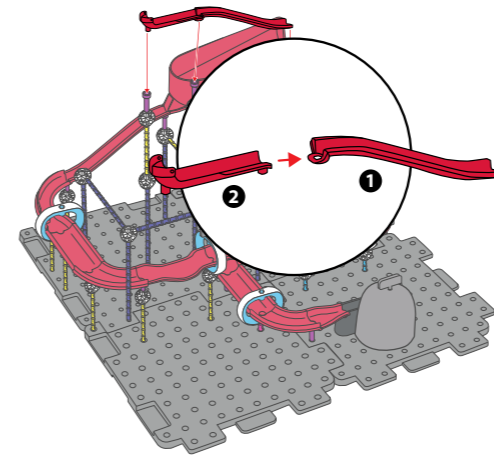
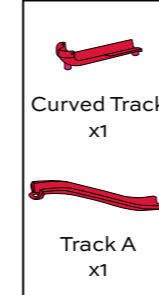



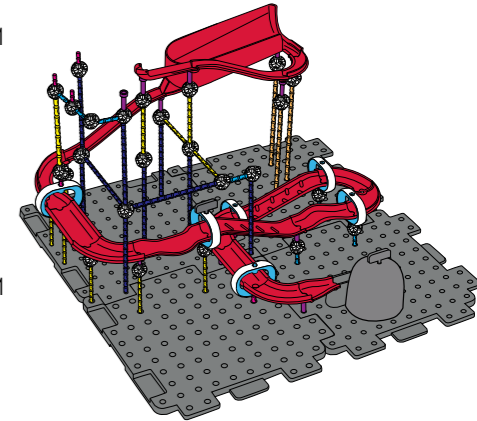
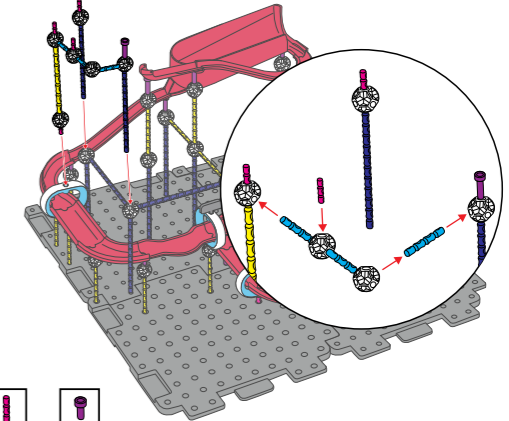
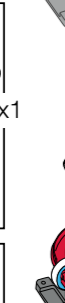
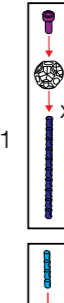
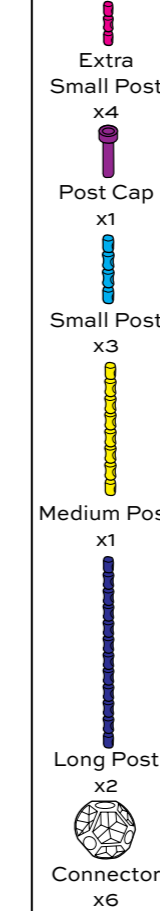



TRIN 14







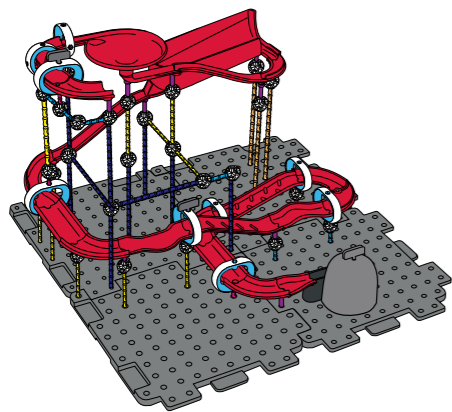
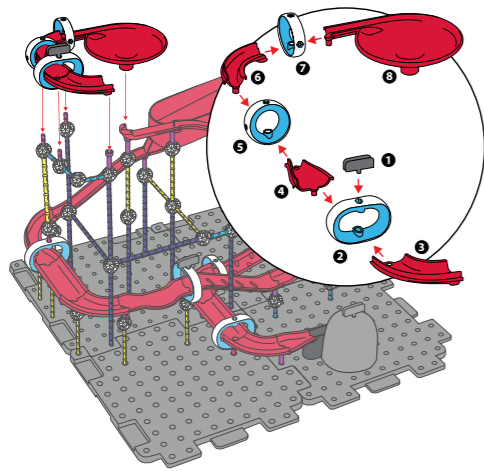

BYGGER 1

TRIN 15

-  Funnel
x1
-  Corner Track A
x1
-  Split Track B
x1
-  Dual Corner Track A
x1
-  Ring
x2
-  Wide Ring
x1
-  Sign Holder
x1



TRIN 16

-  Extra Small Post
x4
-  Post Cap
x2
-  Small Post
x1
-  Medium Post
x5
-  Long Post
x4
-  Extra Long Post
x1
-  Connector
x9

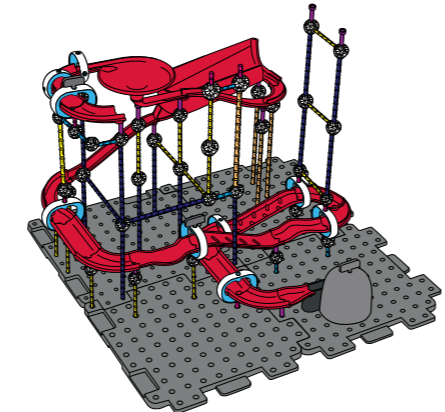
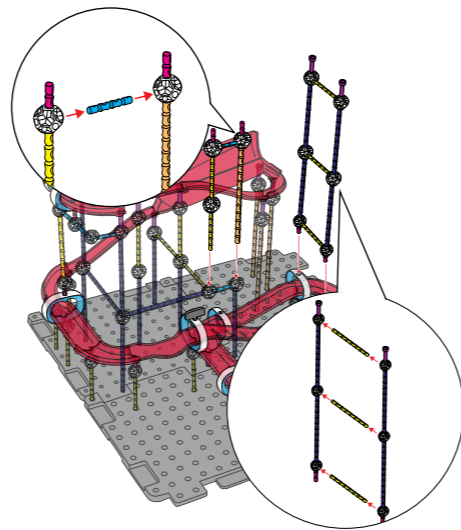

BYGGER 1

TRIN 17

-  Groove Track A
x1
-  Tiny Track A
x1
-  Wide Ring
x2
-  Sign Holder
x1
-  Marble Launcher
x1
-  Starting Track
x1

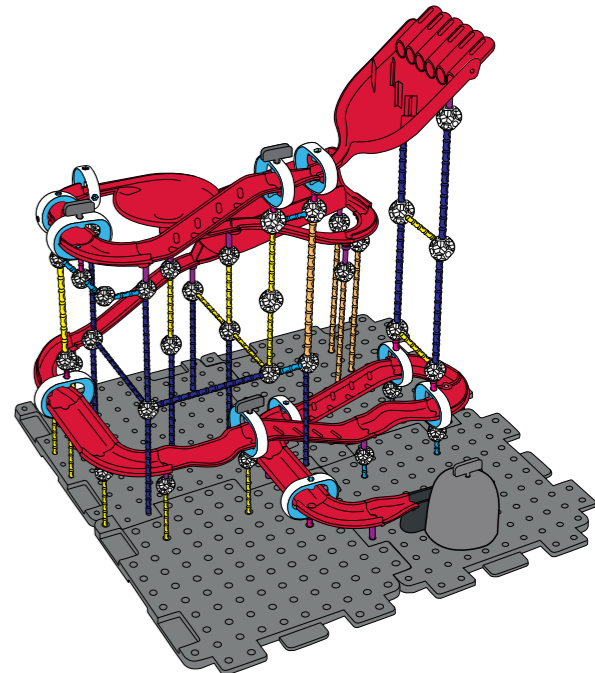
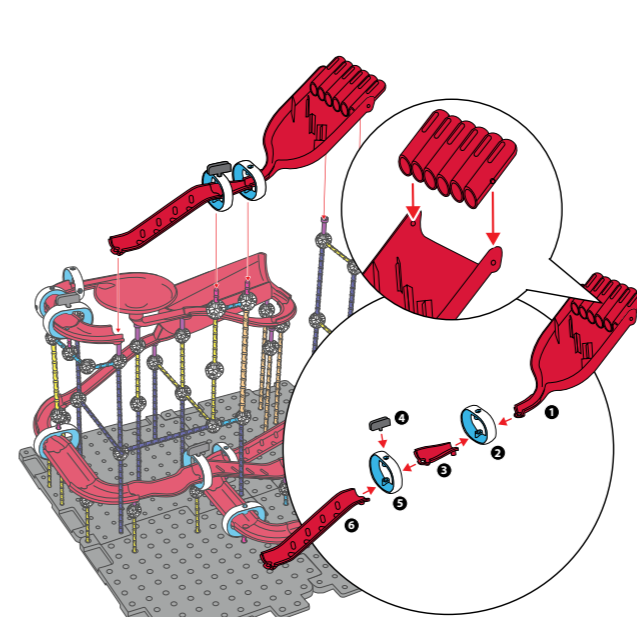

BYGGER 2

TRIN 1

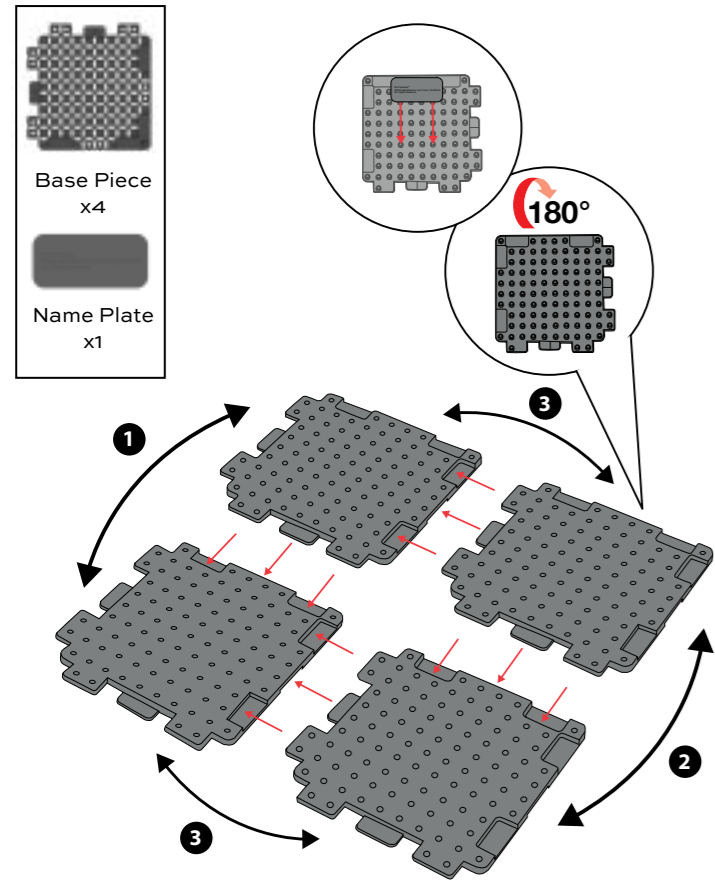

TRIN 2

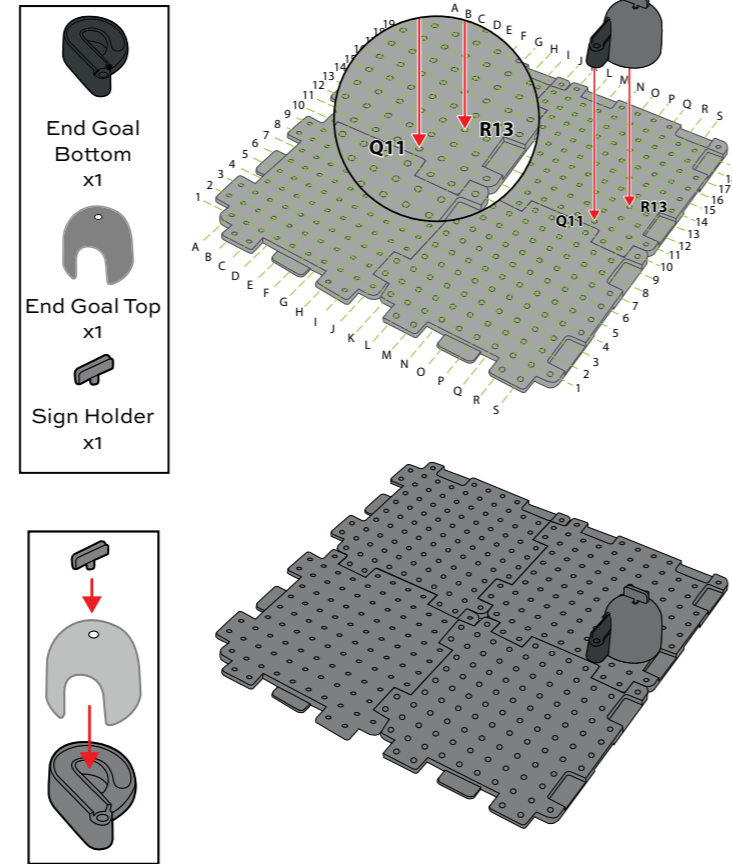

BYGGER 2

TRIN 3

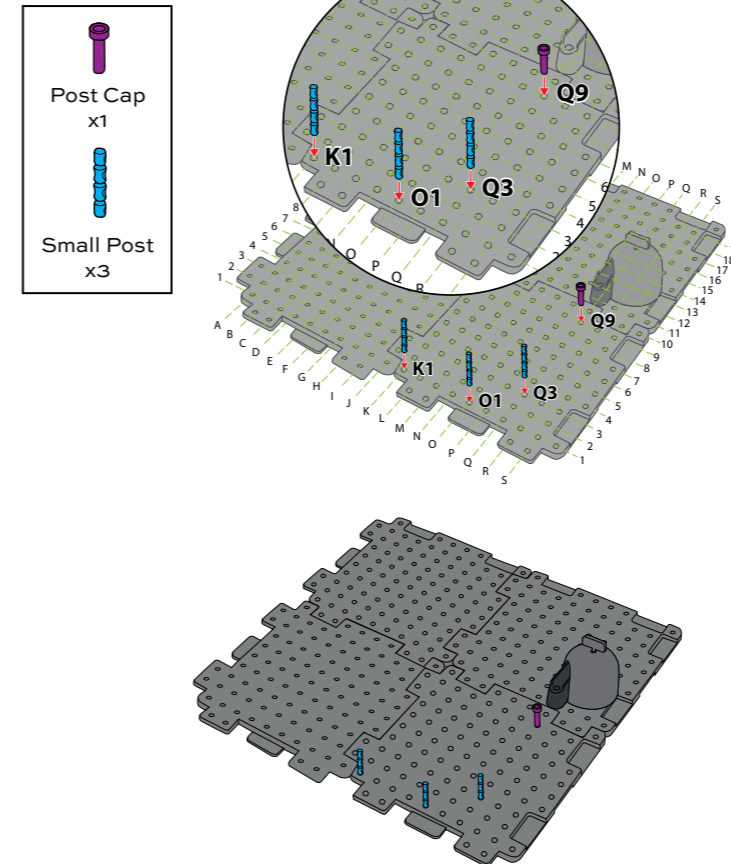



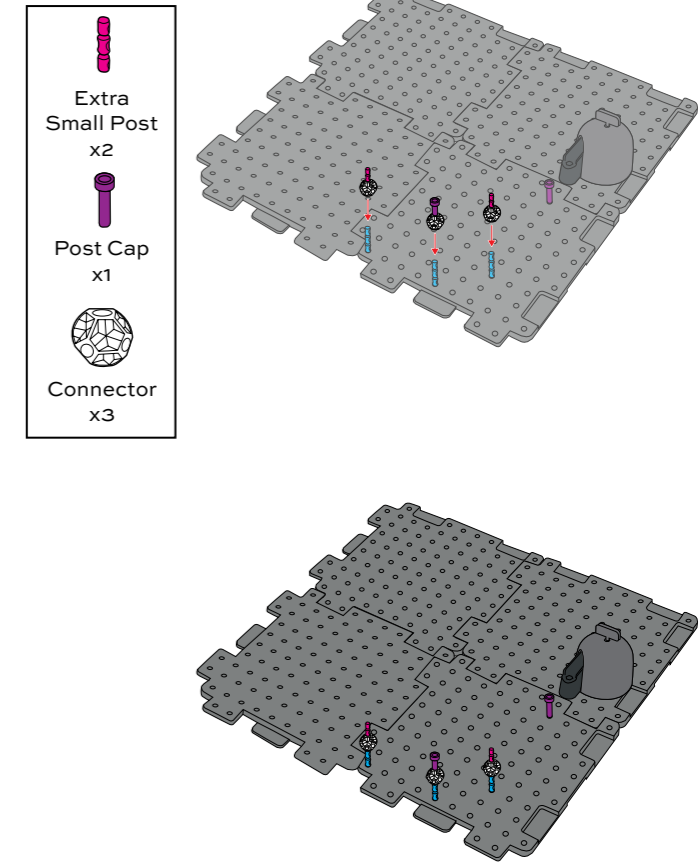

TRIN 4





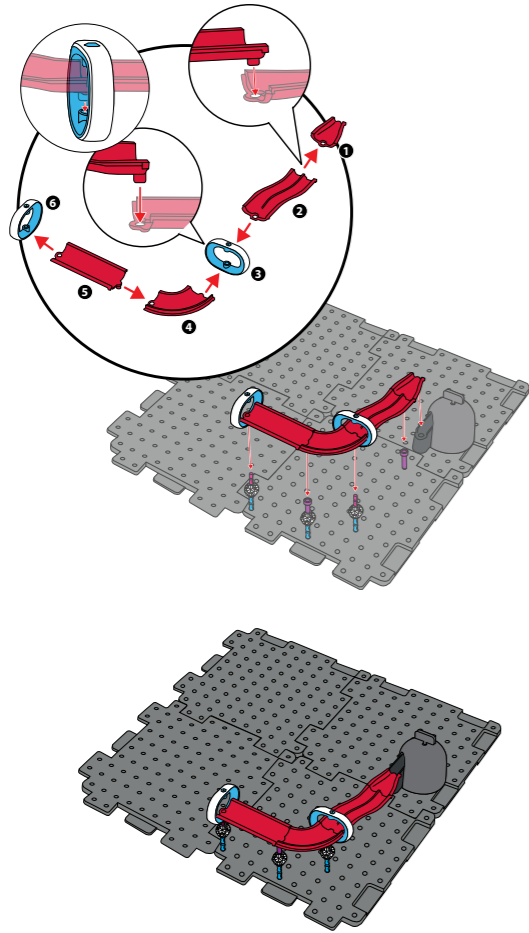

BYGGER 2

TRIN 5

-  Wide Ring
x2
-  Dual Corner Track A
x1
-  Short Dual Track B
x1
-  Tiny Track A
x1
-  Dual Track A
x1





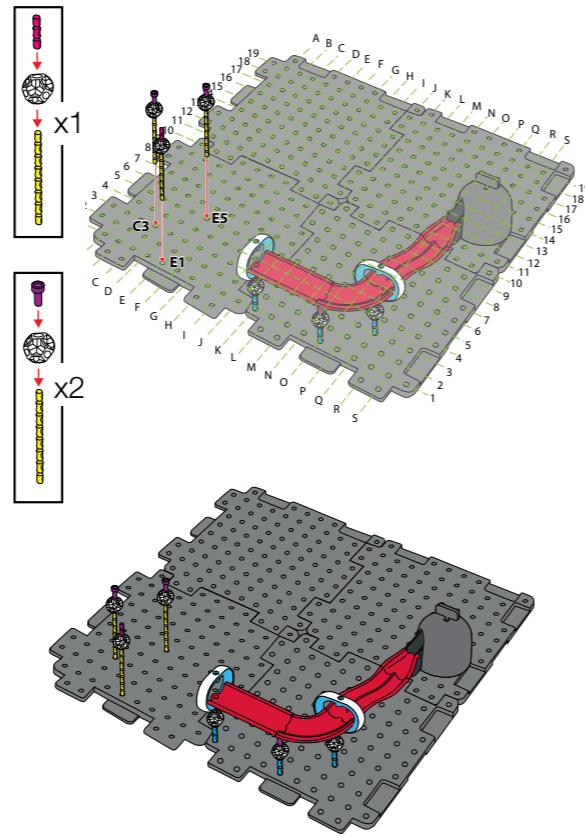

TRIN 6

-  Extra Small Post
x1
-  Post Cap
x2
-  Medium Post
x3
-  Connector
x3







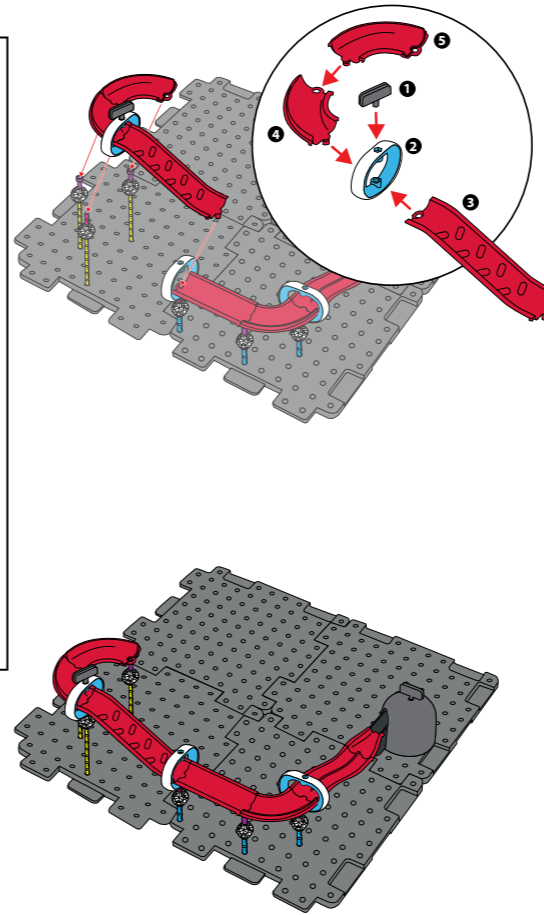

BYGGER 2

TRIN 7

-  Wide Ring
x1
-  Groove Track A
x1
-  Dual Corner Track A
x2
-  Sign Holder
x1



TRIN 8

-  Extra Small Post
x2
-  Post Cap
x2
-  Small Post
x3
-  Medium Post
x1
-  Long Post
x2
-  Connector
x5

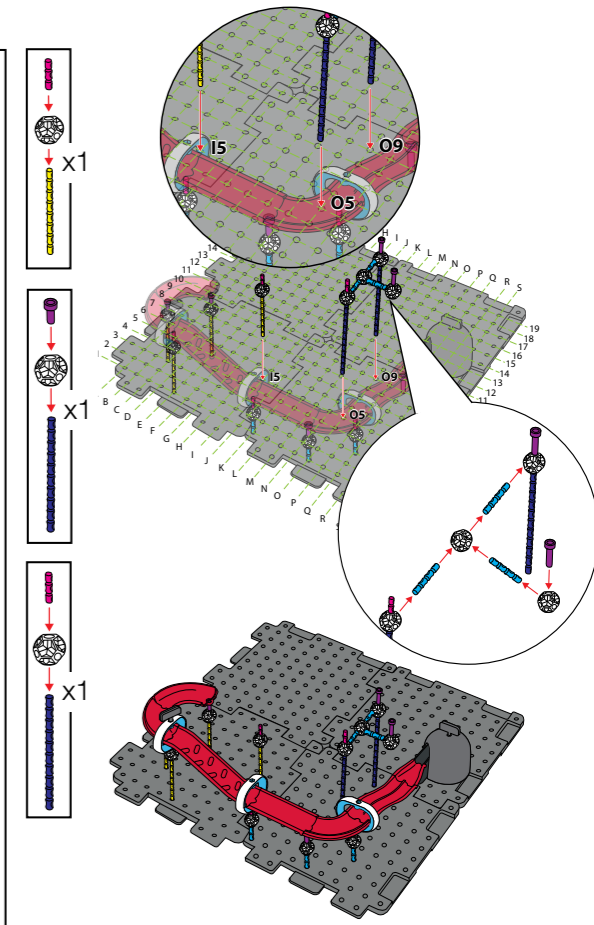

BYGGER 2

TRIN 9

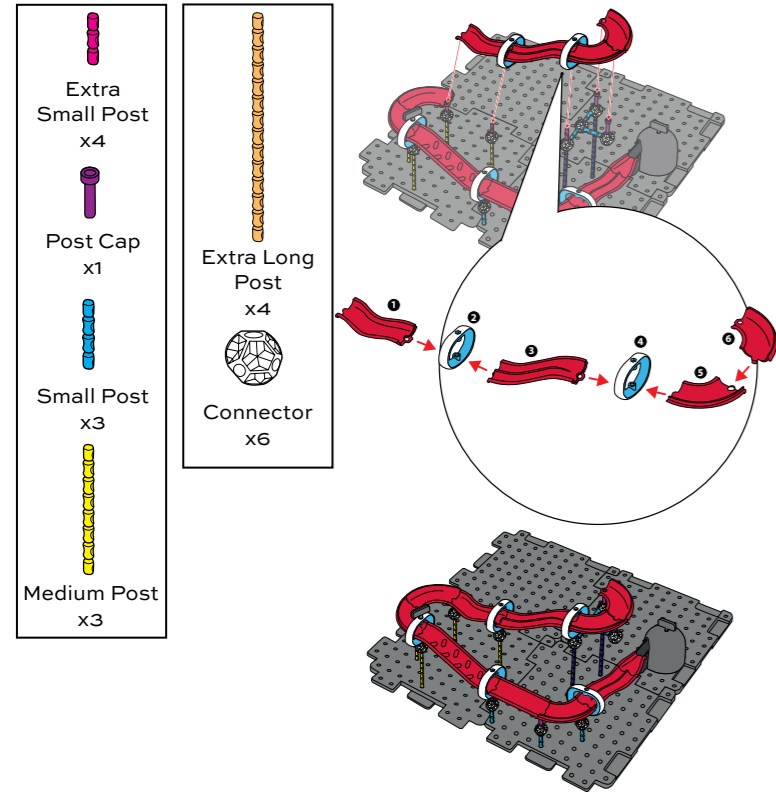

TRIN 10

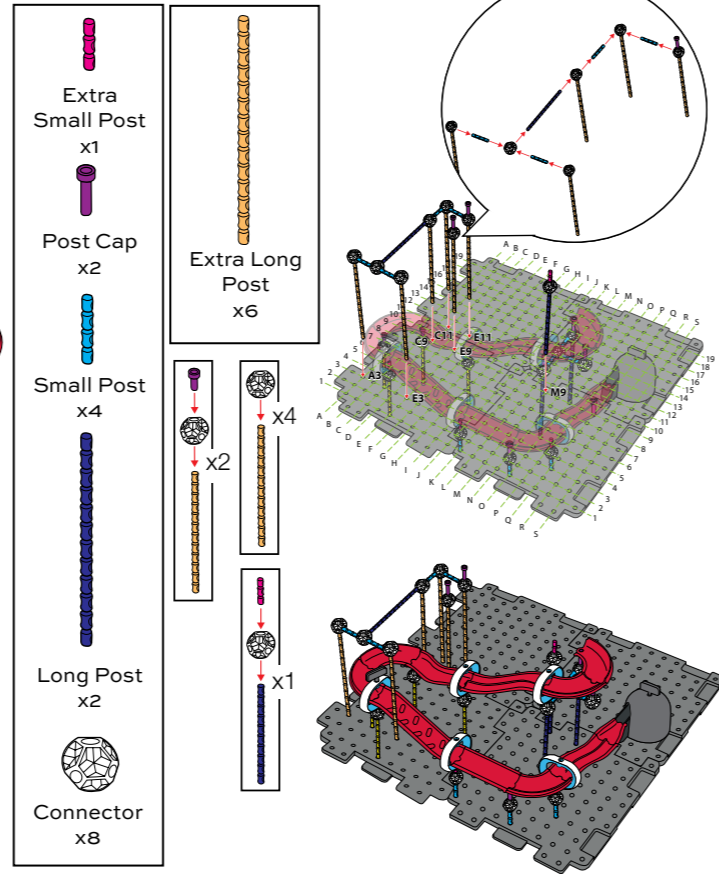

BYGGER 2

TRIN 11

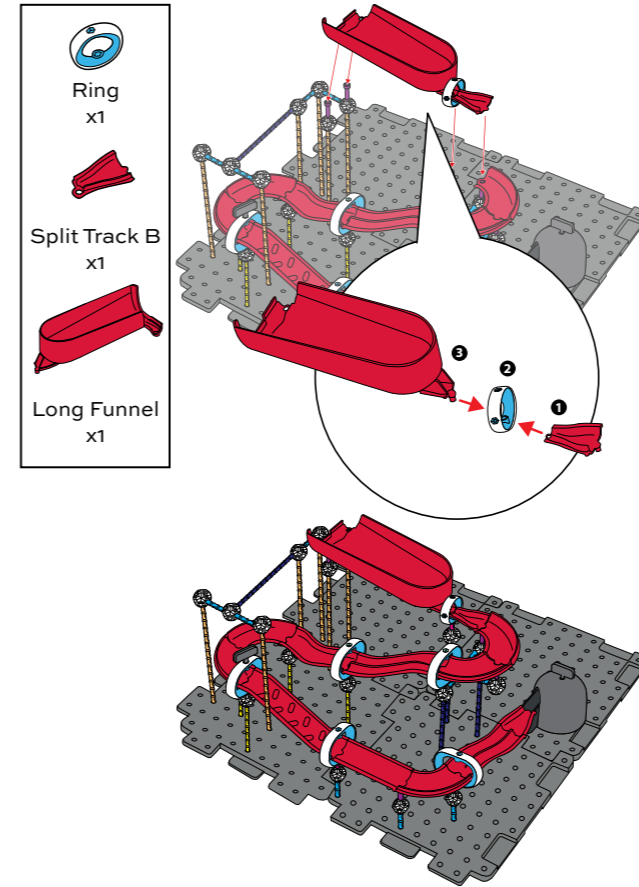



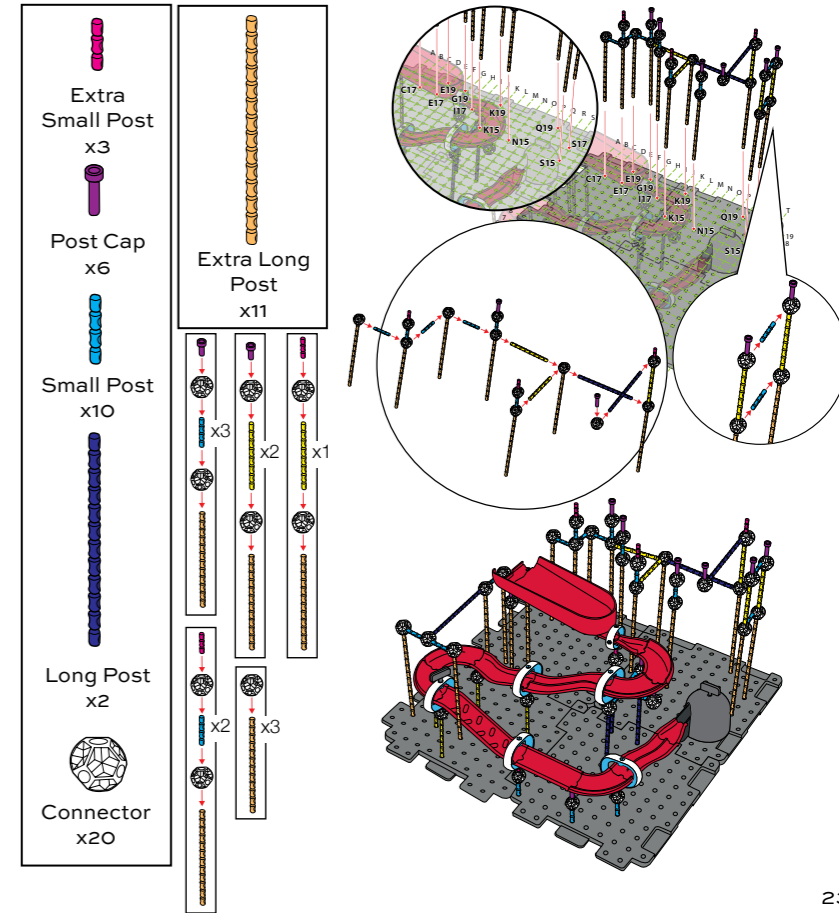

TRIN 12









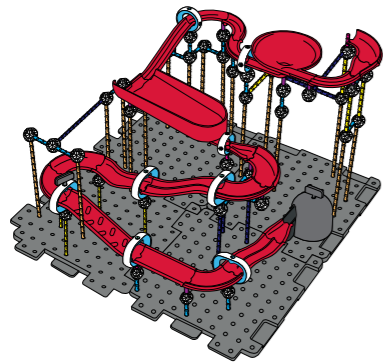
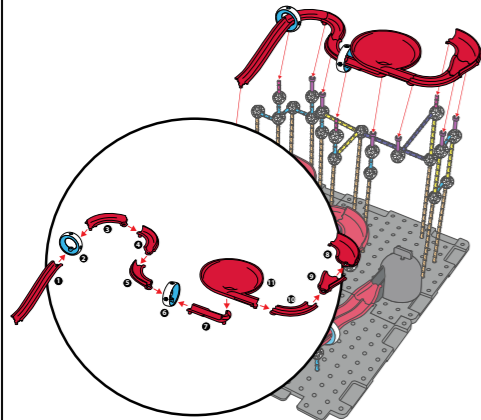



BYGGER 2

TRIN 13

-  Extra Small Post x5
-  Small Post x1
-  Medium Post x1
-  Long Post x2
-  Connector x5







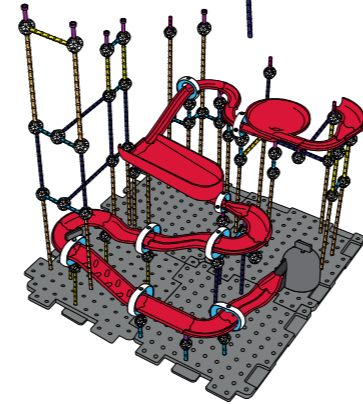
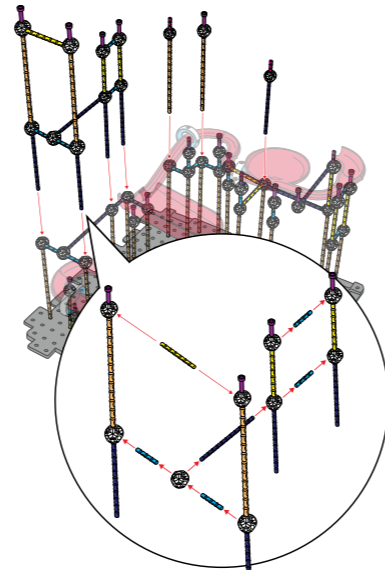

TRIN 14

-  Extra Small Post x3
-  Post Cap x6
-  Small Post x10
-  Long Post x2
-  Connector x20
-  Extra Long Post x11
-  x2
-  x2
-  x1
-  x1
-  x1

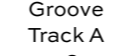

BYGGER 2

TRIN 15

-  Wide Ring x3
-  Tiny Track A x1
-  Groove Track A x2
-  Marble Launcher x1
-  Starting Track x1
-  Dual Corner Track A x1
-  Dual Track B x1
-  Sign Holder x1

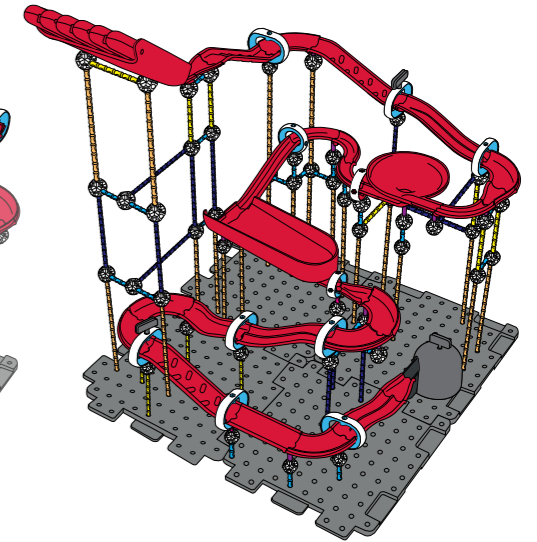
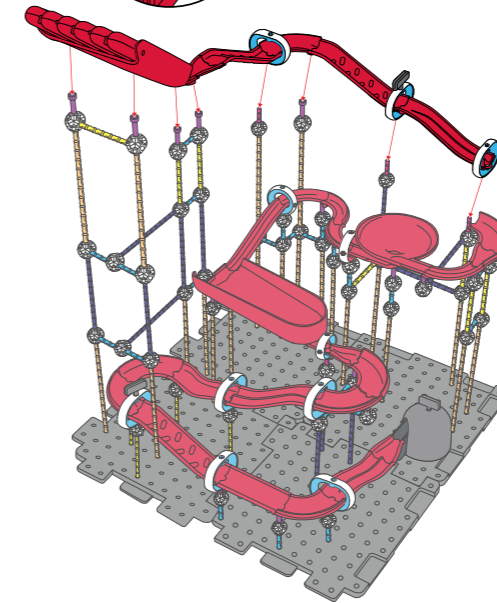
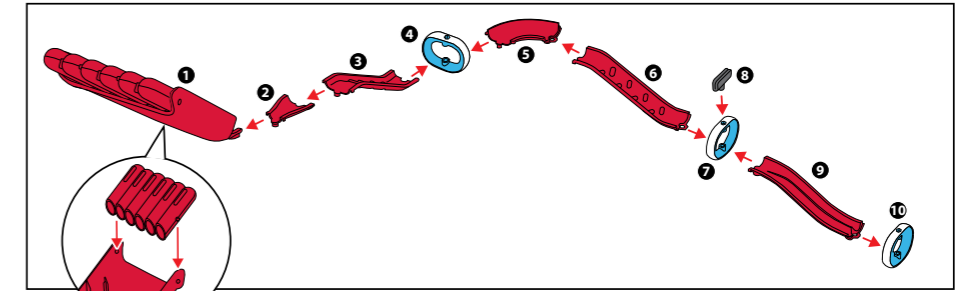

BYGGER 3

TRIN 1

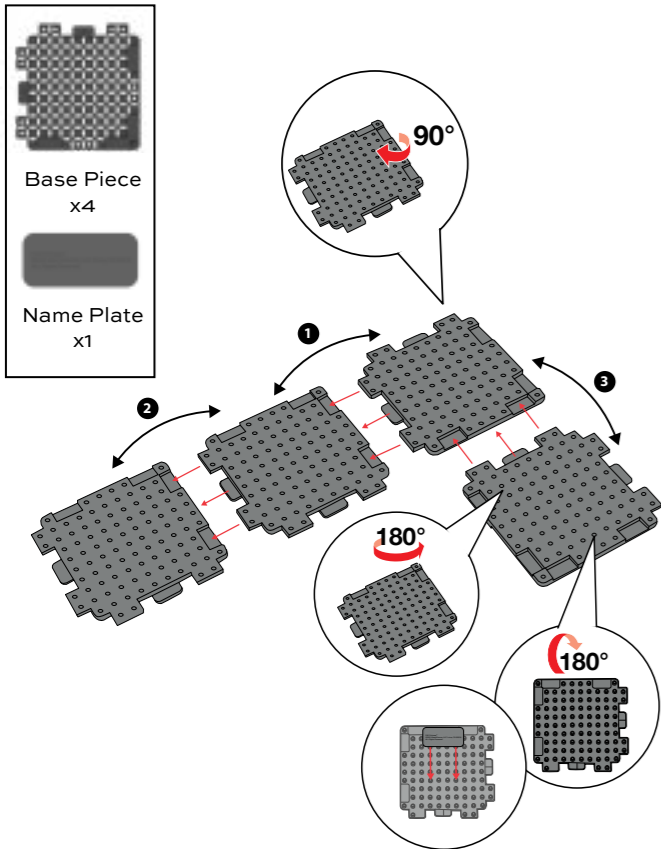

TRIN 2

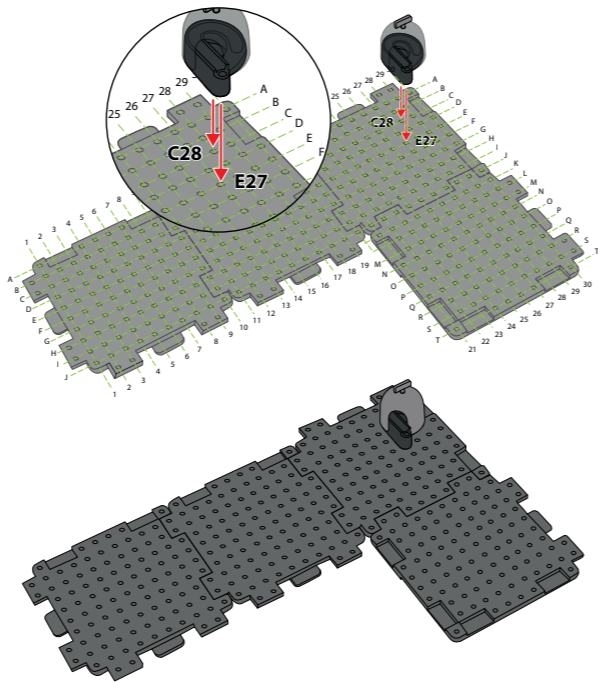

BYGGER 3

TRIN 3

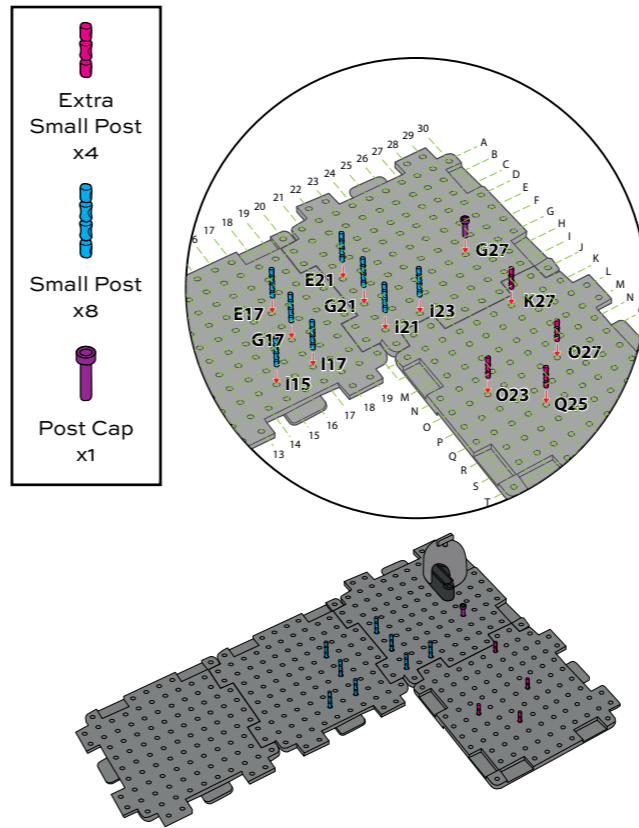

TRIN 4

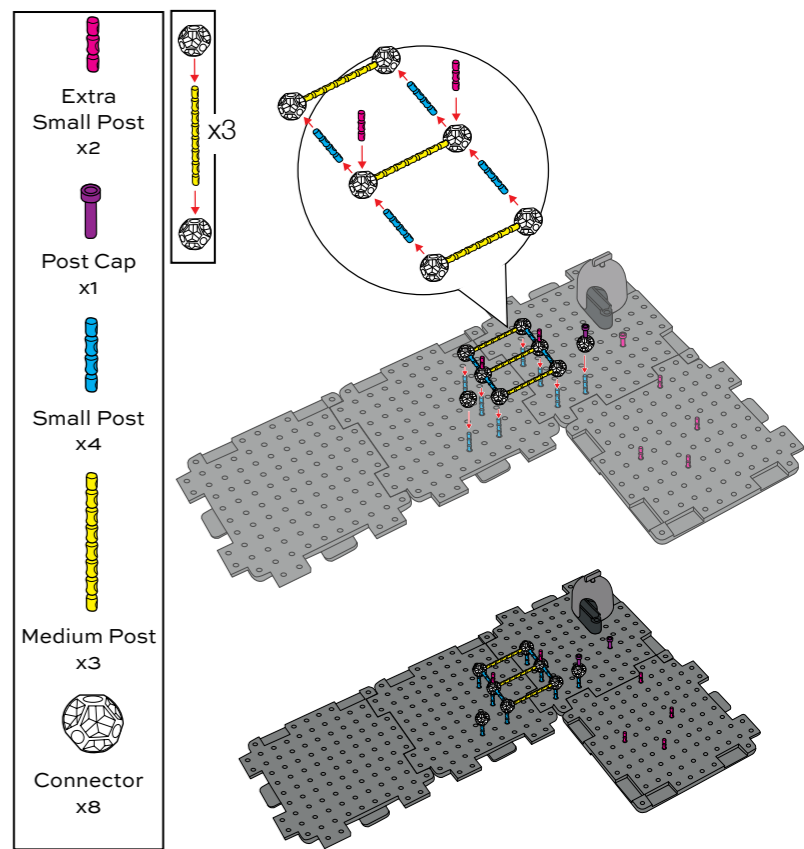

BYGGER 3

TRIN 5

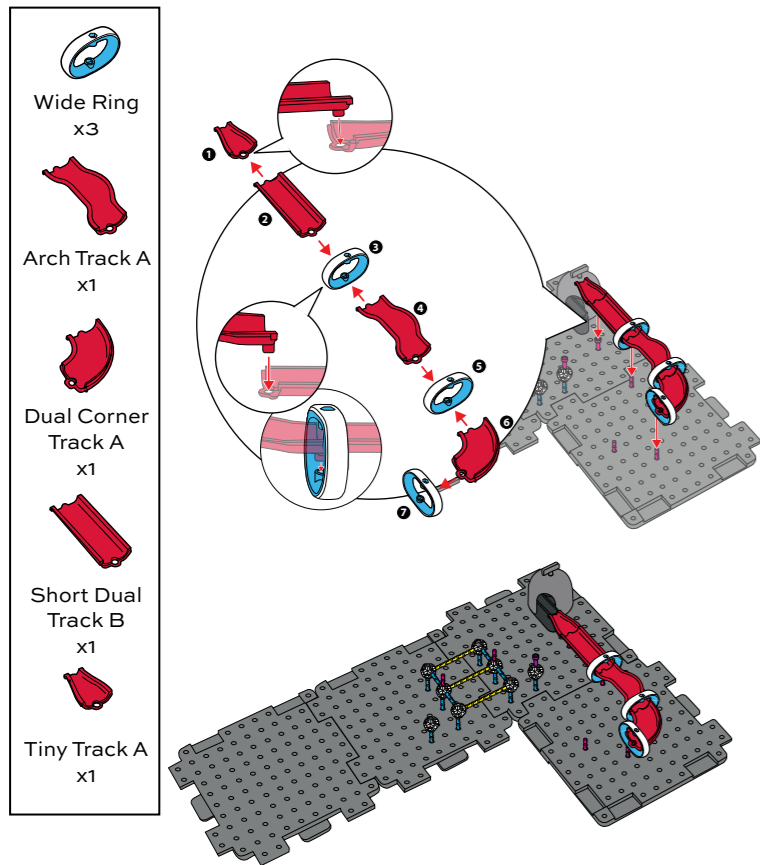

TRIN 6

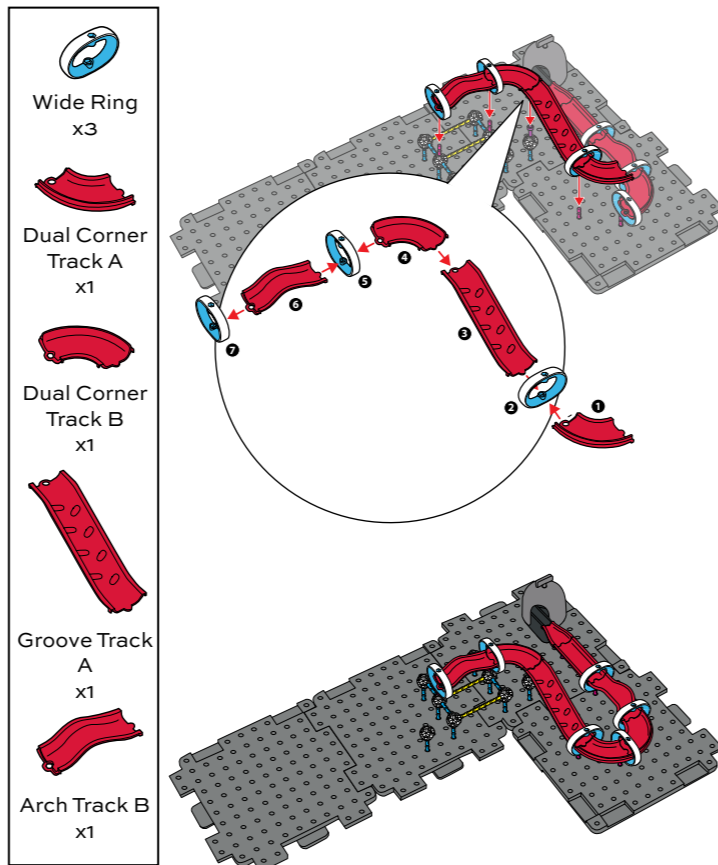

BYGGER 3

TRIN 7

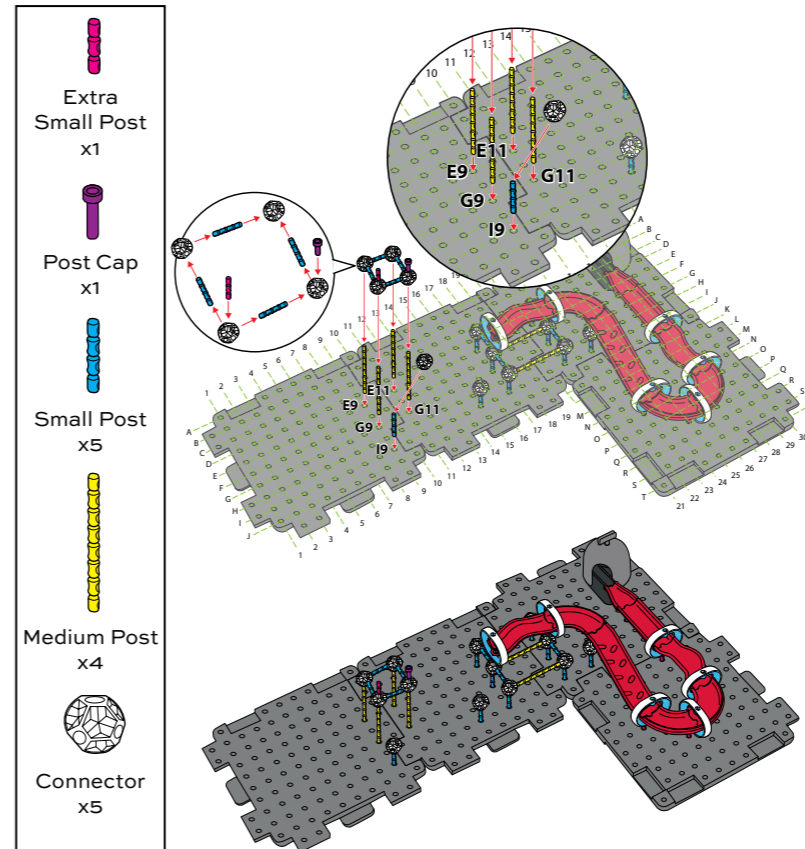

TRIN 8

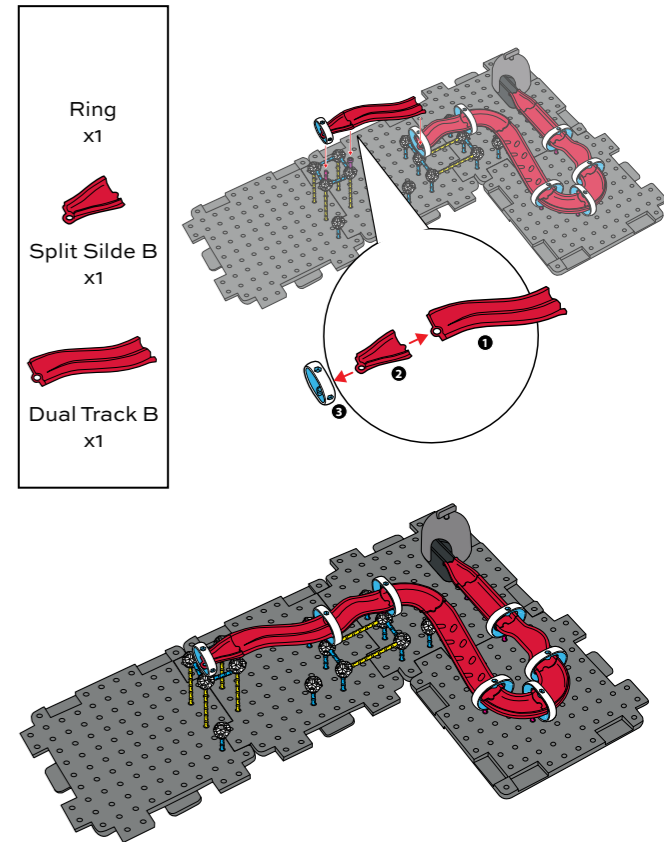

BYGGER 3

TRIN 9

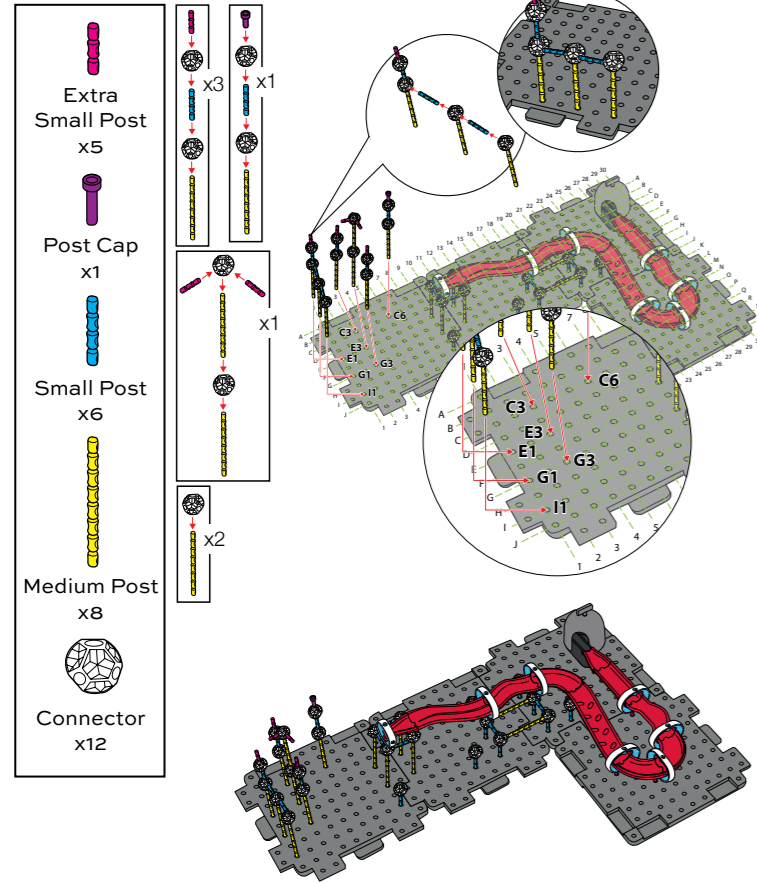

TRIN 10

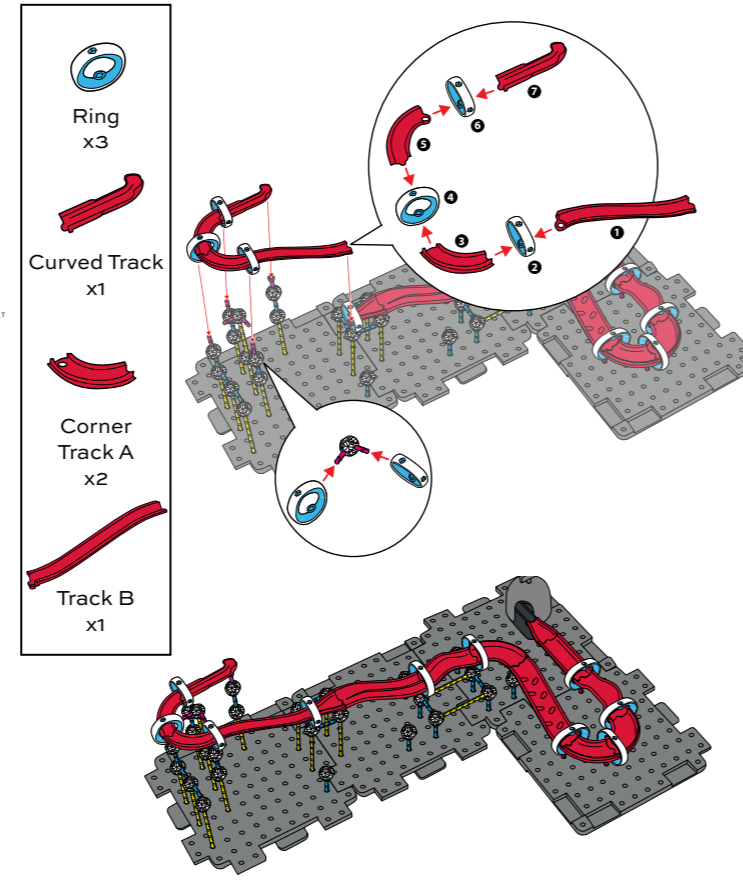

BYGGER 3

TRIN 11

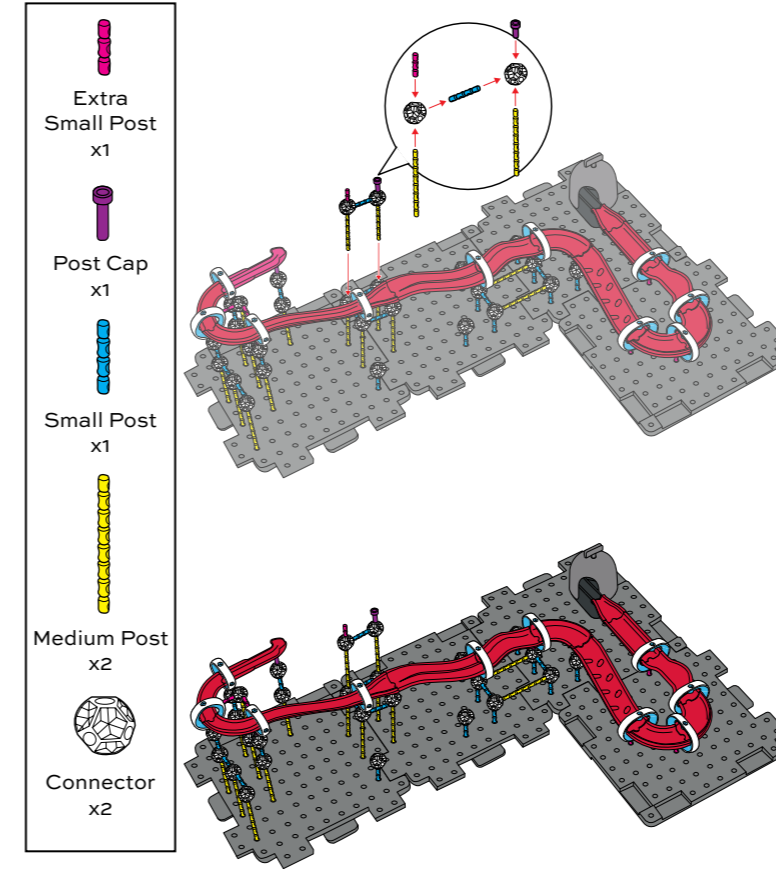

TRIN 12

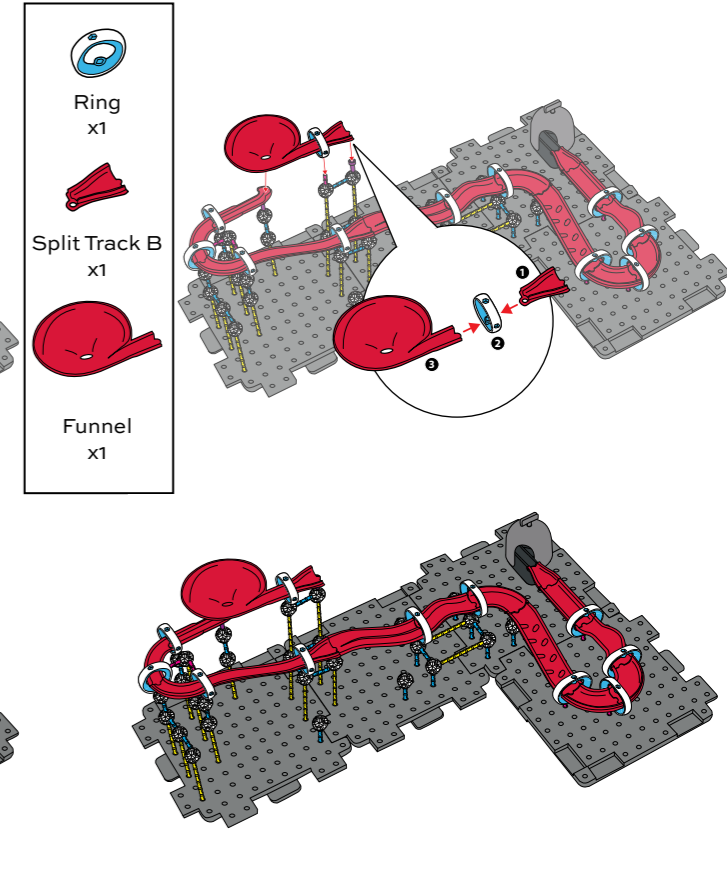

BYGGER 3

TRIN 13

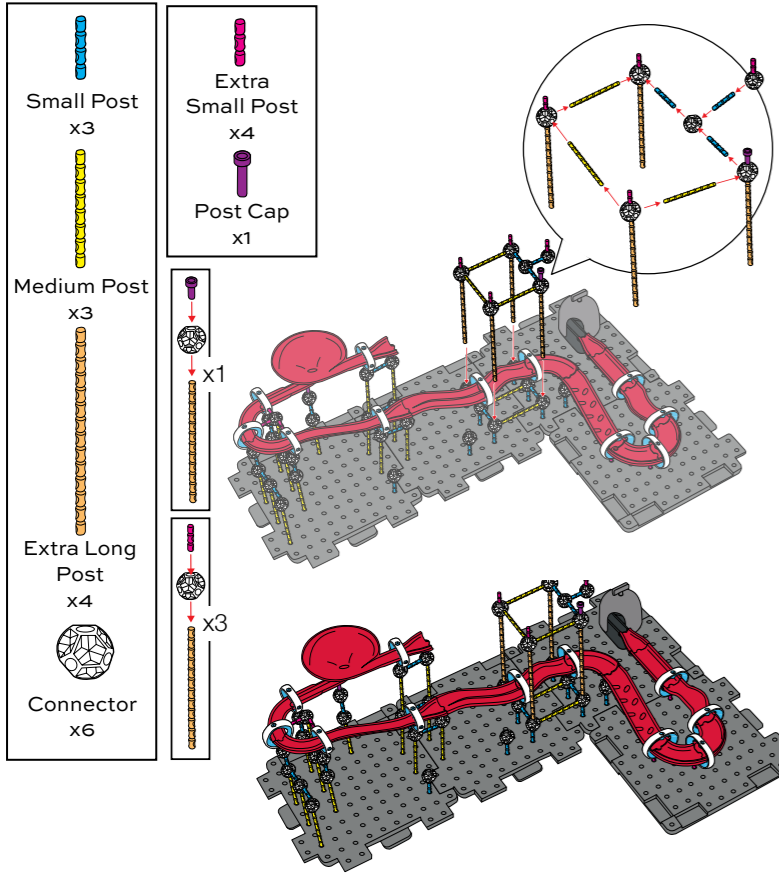

TRIN 14

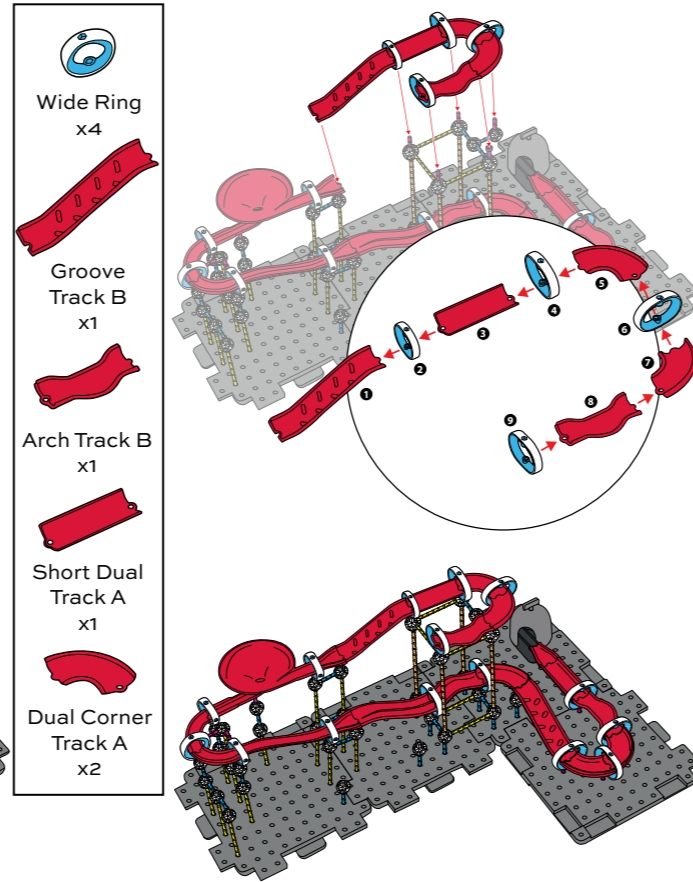

BYGGER 3

TRIN 15

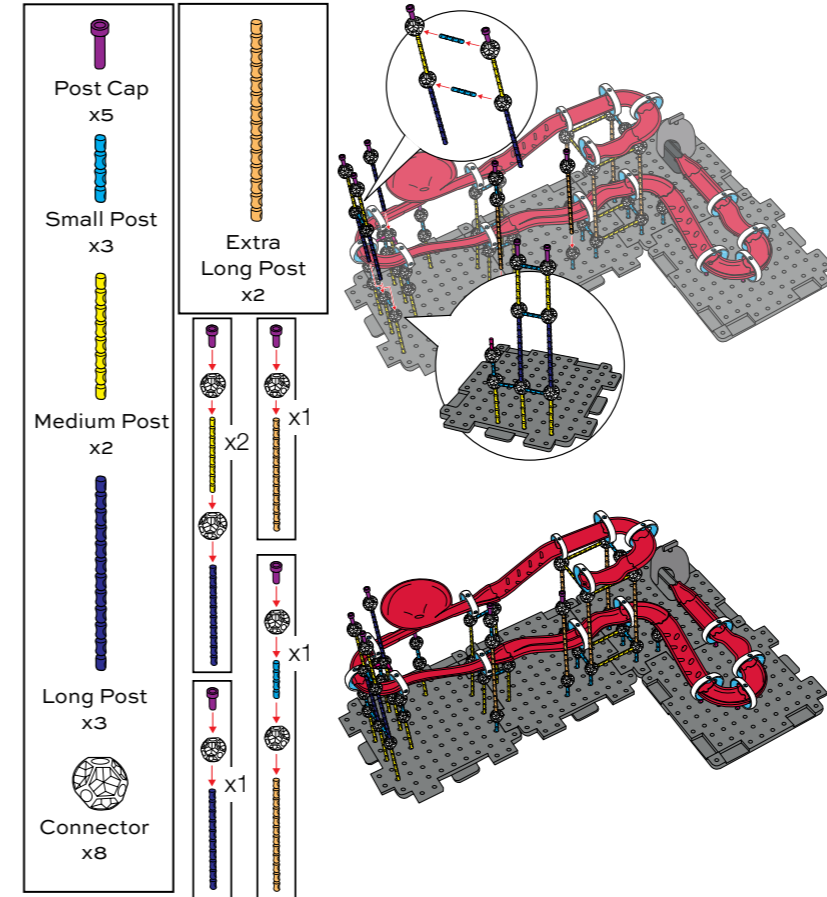



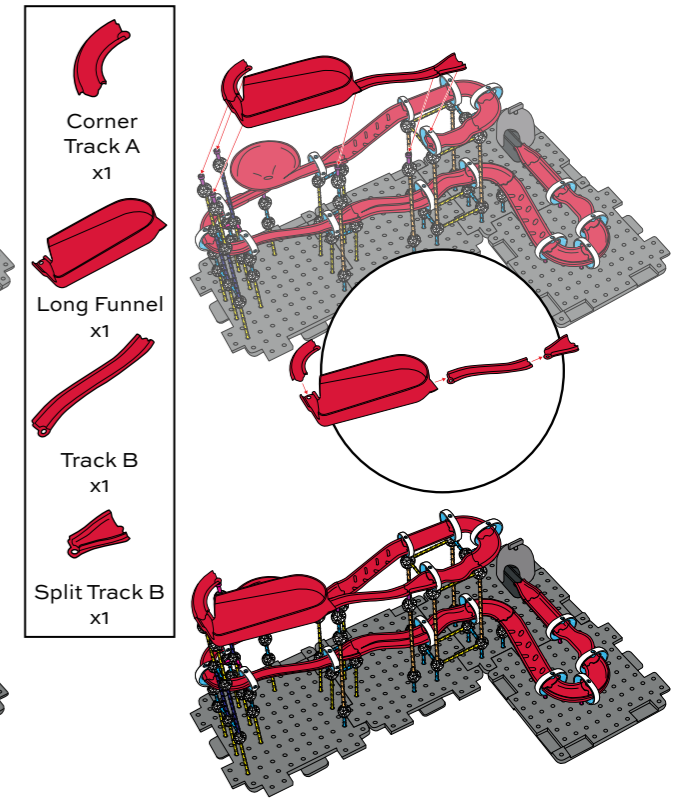

TRIN 16





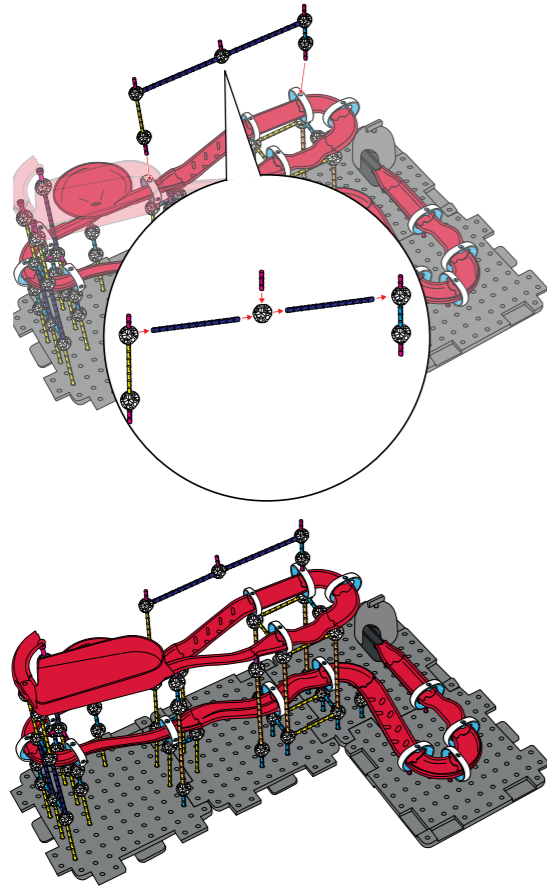

BYGGER 3

TRIN 17

-  Extra Small Post x5
-  Small Post x1
-  Medium Post x1
-  Long Post x2
-  Connector x5





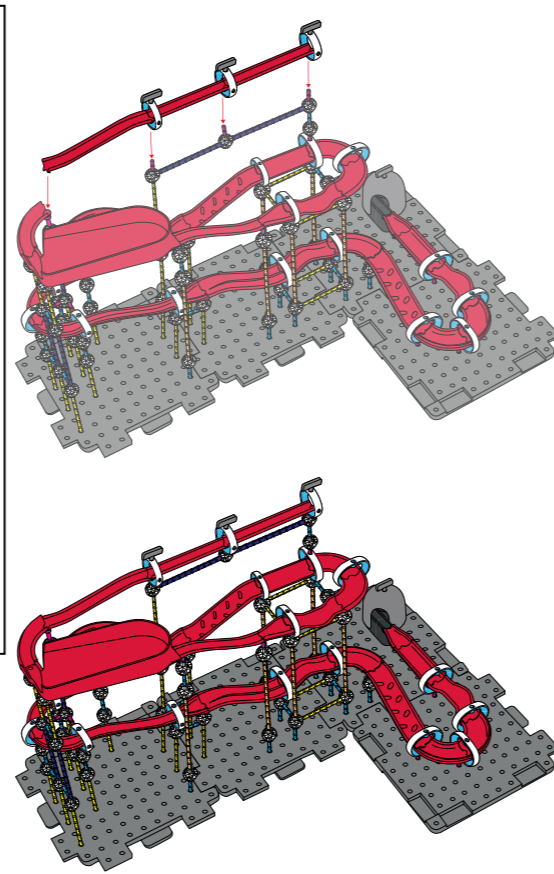

TRIN 18

-  Ring x3
-  Track B x1
-  Long Track x2
-  Sign Holder x3





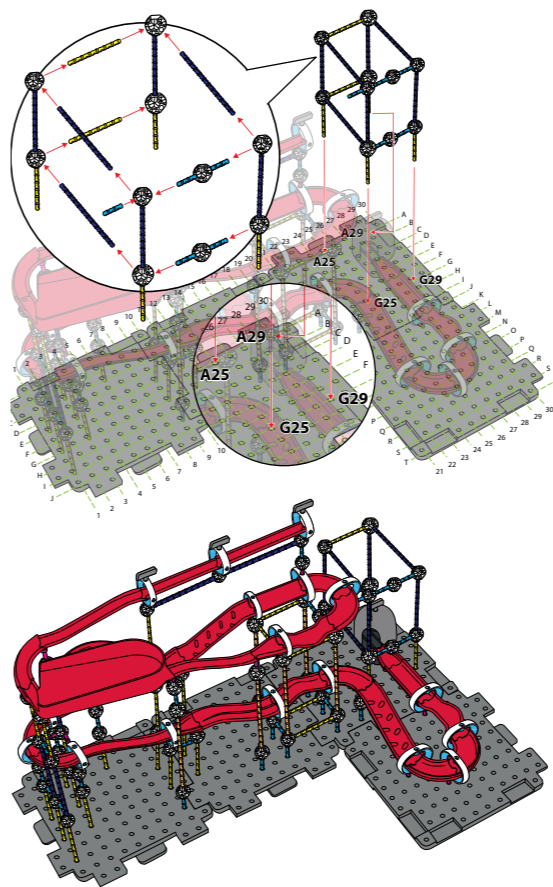

BYGGER 3

TRIN 19

-  Small Post x5
-  Medium Post x6
-  Long Post x7
-  Connector x10



TRIN 20

-  Extra Small Post x4
-  Small Post x6
-  Medium Post x3
-  Long Post x4
-  Connector x10

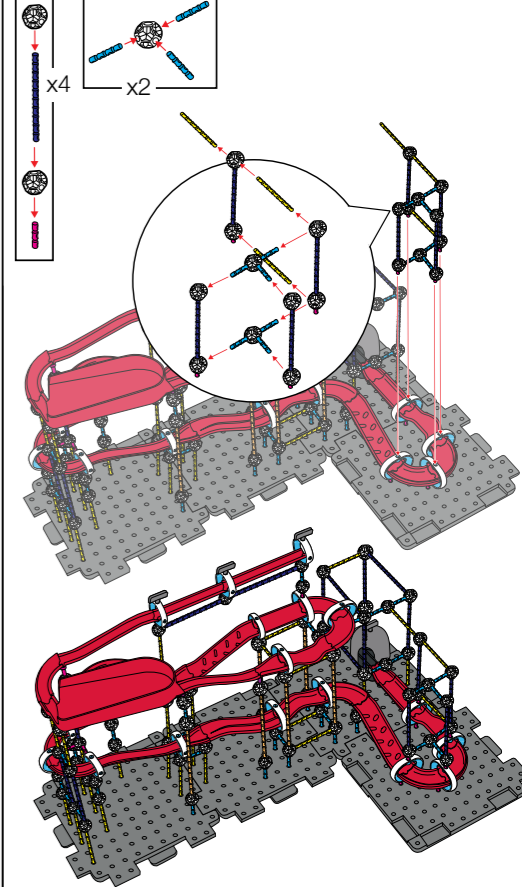

BYGGER 3

TRIN 21

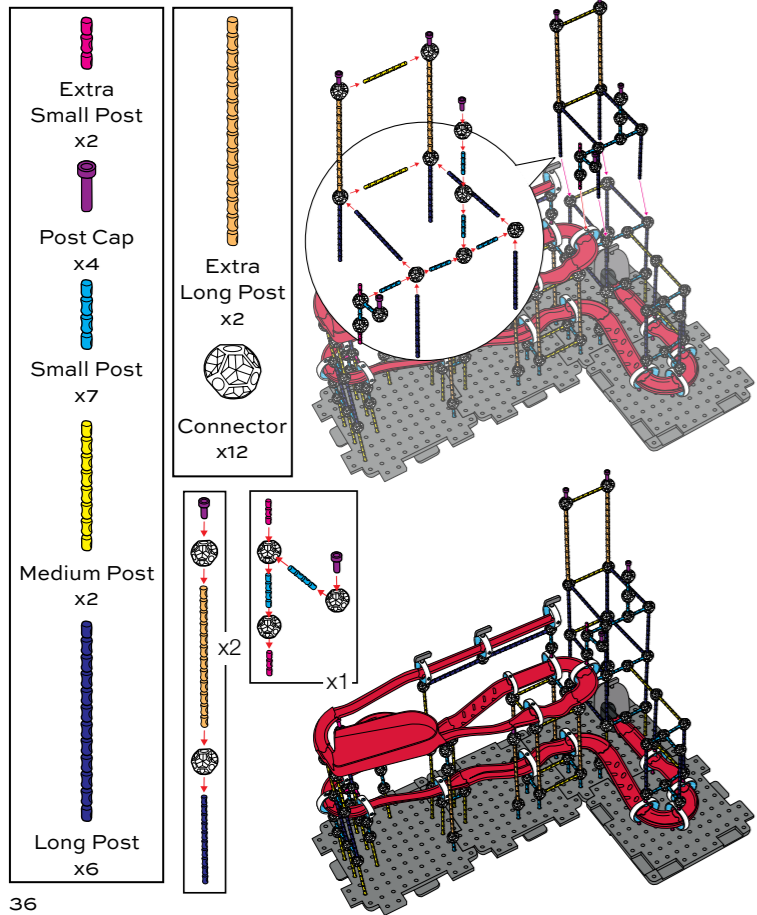

TRIN 22

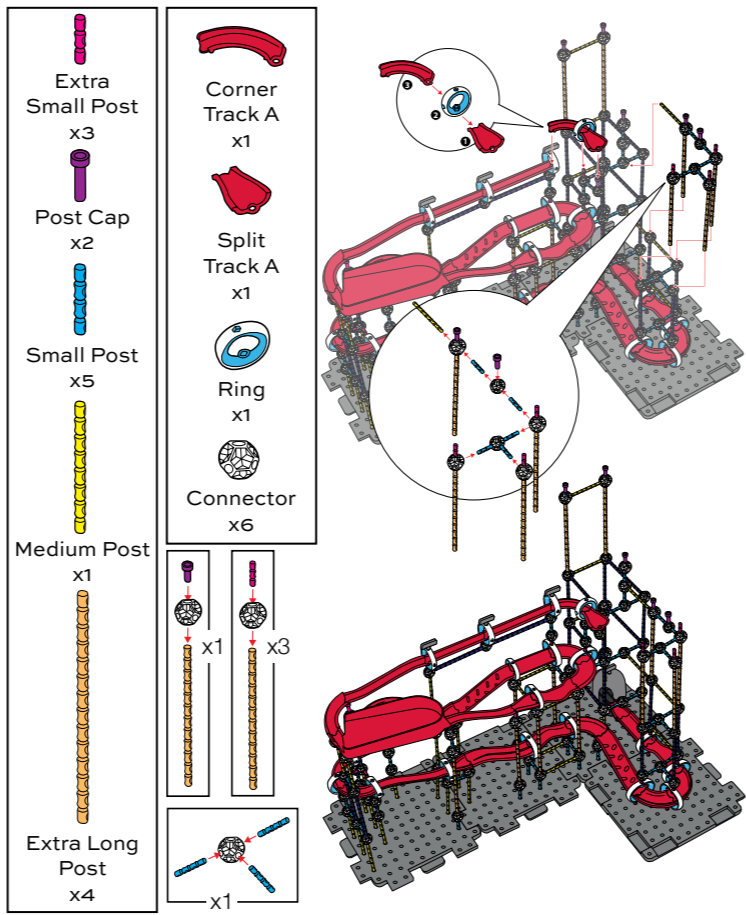

BYGGER 3

TRIN 23

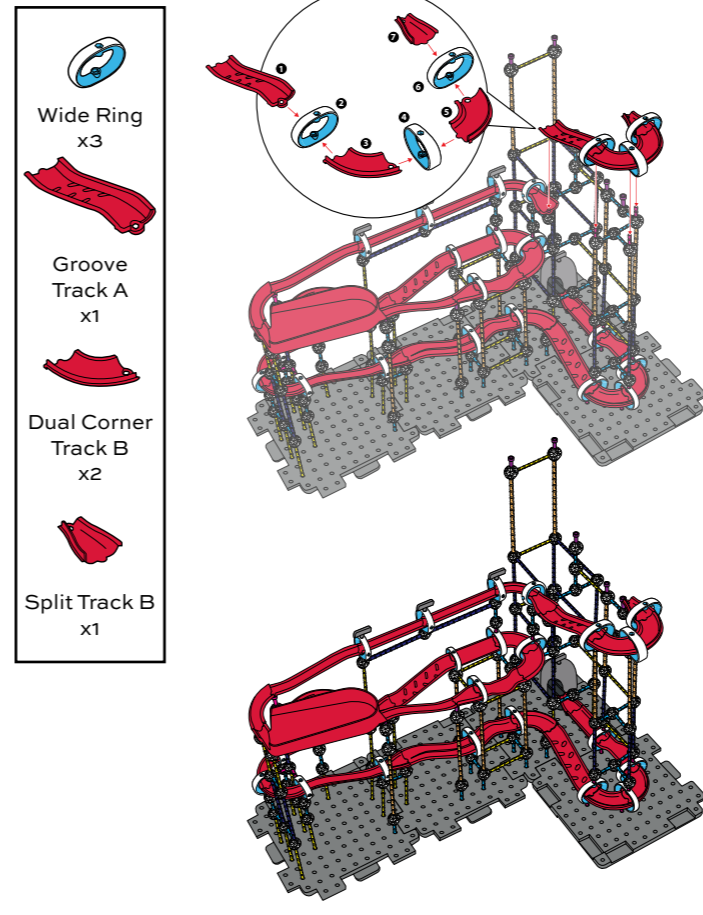

TRIN 24

