

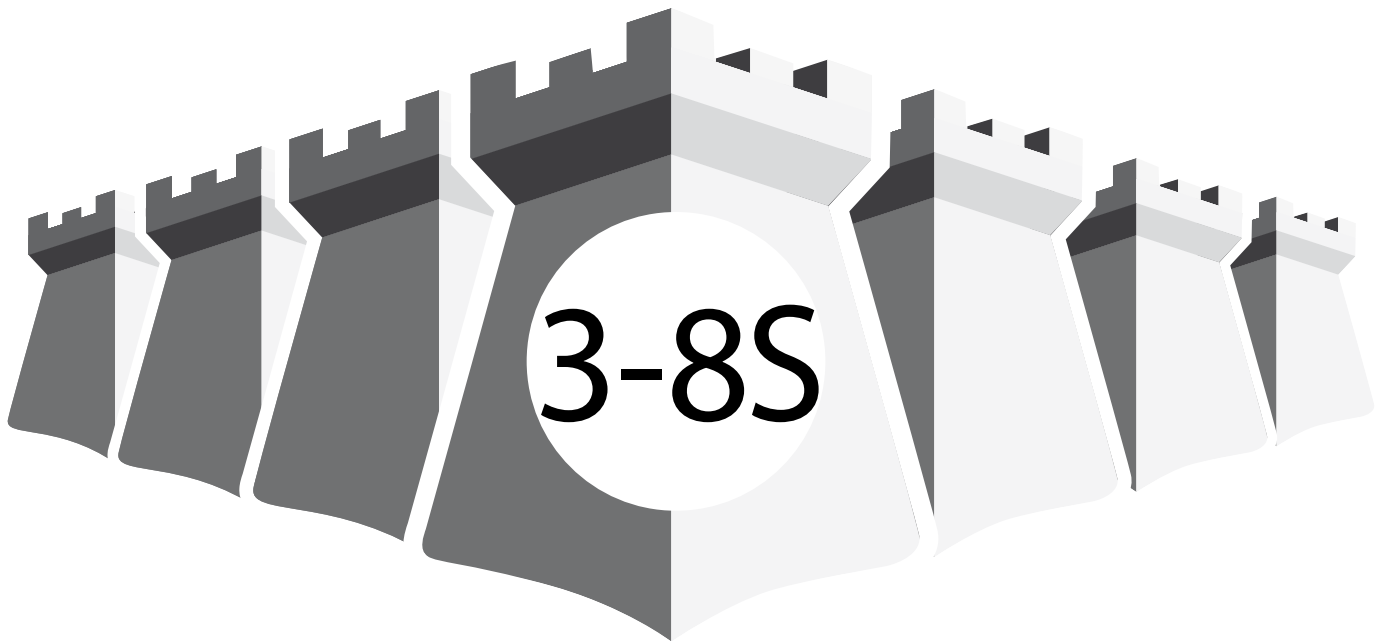

OWNER'S MANUAL

PART

# 3



SWING MODULE  
ASSEMBLY





**HY-LAND**

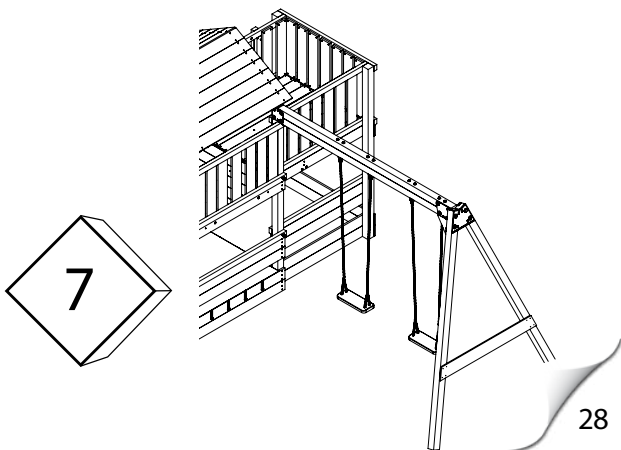
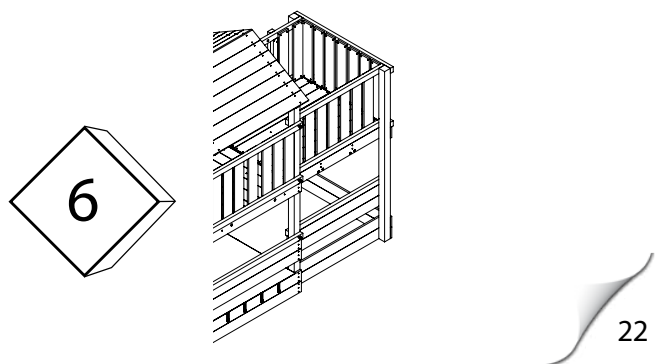
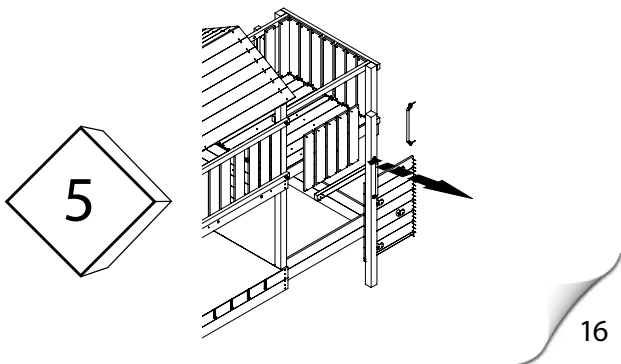
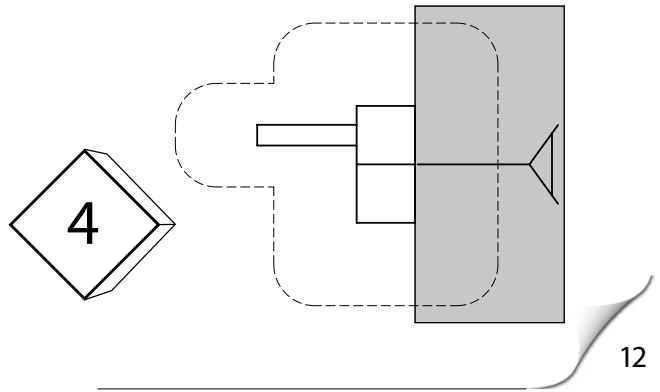
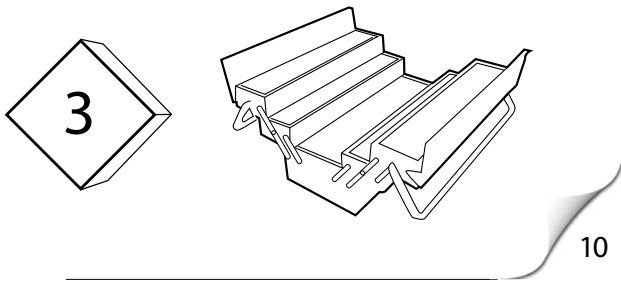
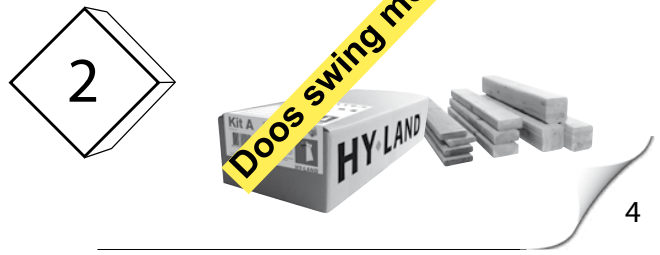
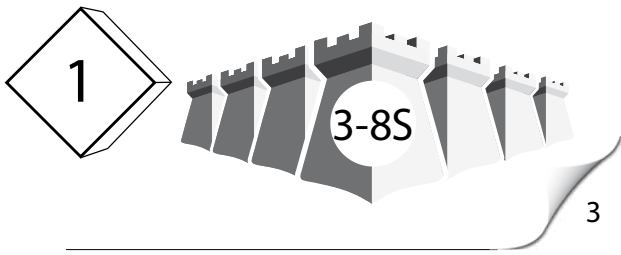

# Assembly steps



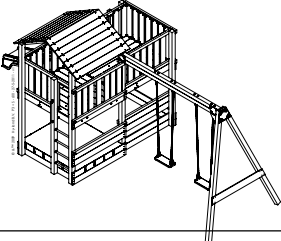

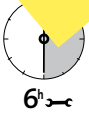

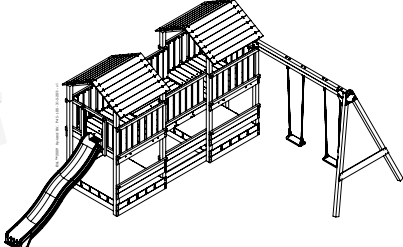
# 1

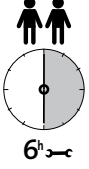

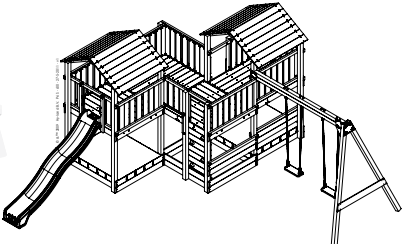
Alle tijden  
4uur

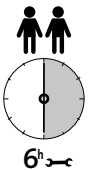

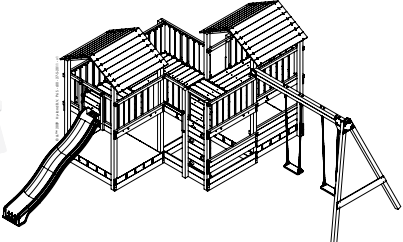
3s  3 +  1x +  0.2 m<sup>3</sup> 

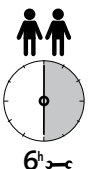
4s  4 +  1x +  0.2 m<sup>3</sup> 

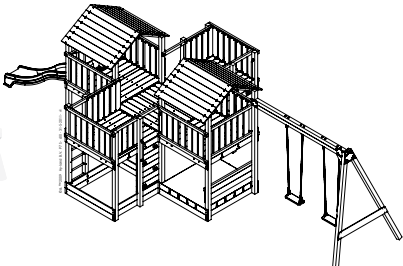
5s  5 +  1x +  0.2 m<sup>3</sup> 

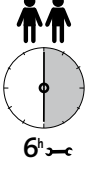
6s  6 +  1x +  0.2 m<sup>3</sup> 

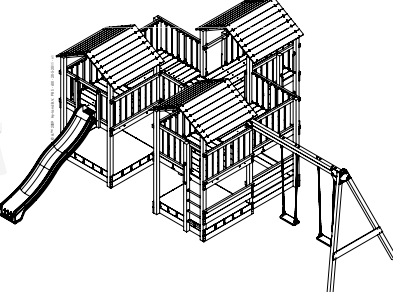
7s  7 +  1x +  0.2 m<sup>3</sup> 

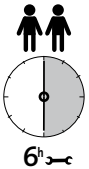
8s  8 +  1x +  0.2 m<sup>3</sup> 

2.1

S

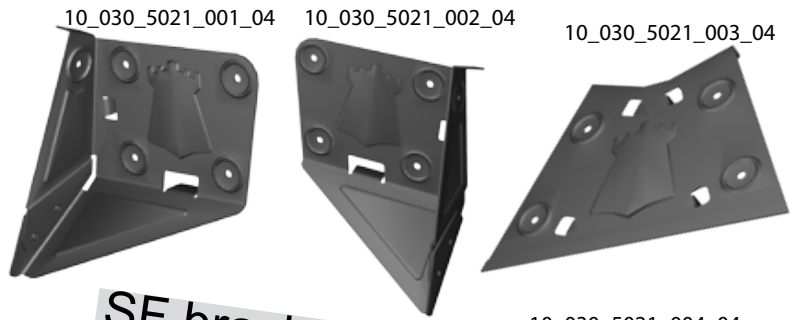

SF bracket  
10\_032\_5013\_325\_01



10\_209\_2071\_103\_24

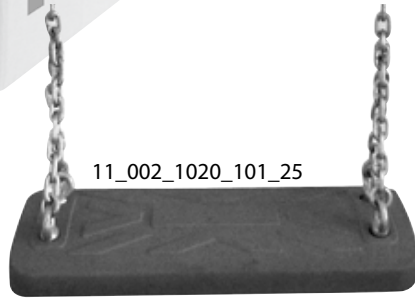

11\_002\_1020\_101\_25

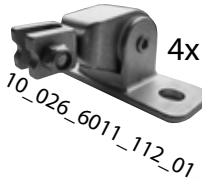

4x



10\_030\_5021\_004\_04



10\_467\_3020\_101\_26

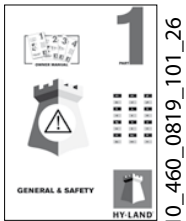

1

10\_460\_0819\_101\_26



2

10\_460\_0219\_100\_26



3

10\_460\_0210\_100\_26

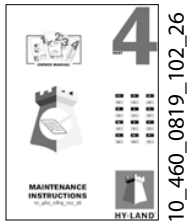

4

10\_460\_0819\_102\_26



T25

T40

ø5 mm

ø3 mm

M8

2.3

# TIMBER

105 mm  
± 17 mm

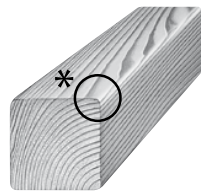

105 mm ± 17 mm

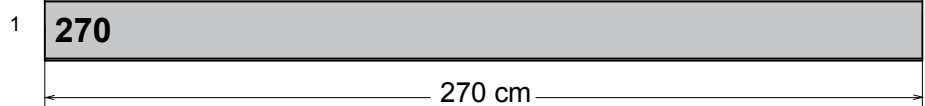

70 mm  
± 5 mm



45 mm ± 1 mm

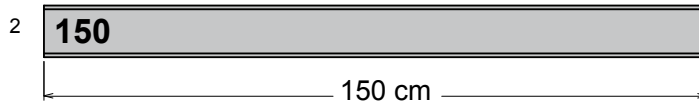

144 mm  
± 2 mm



20 mm ± 2 mm

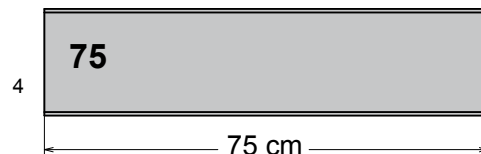

# 2.2

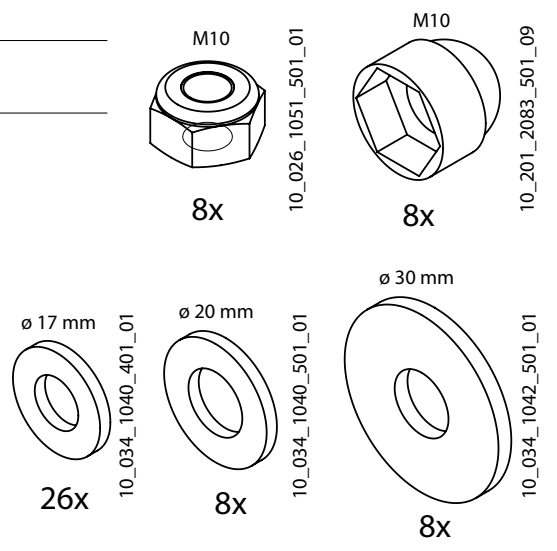
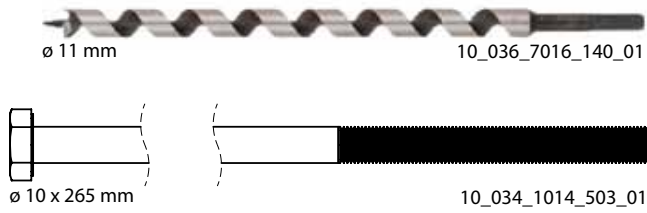
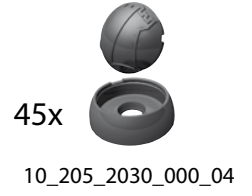
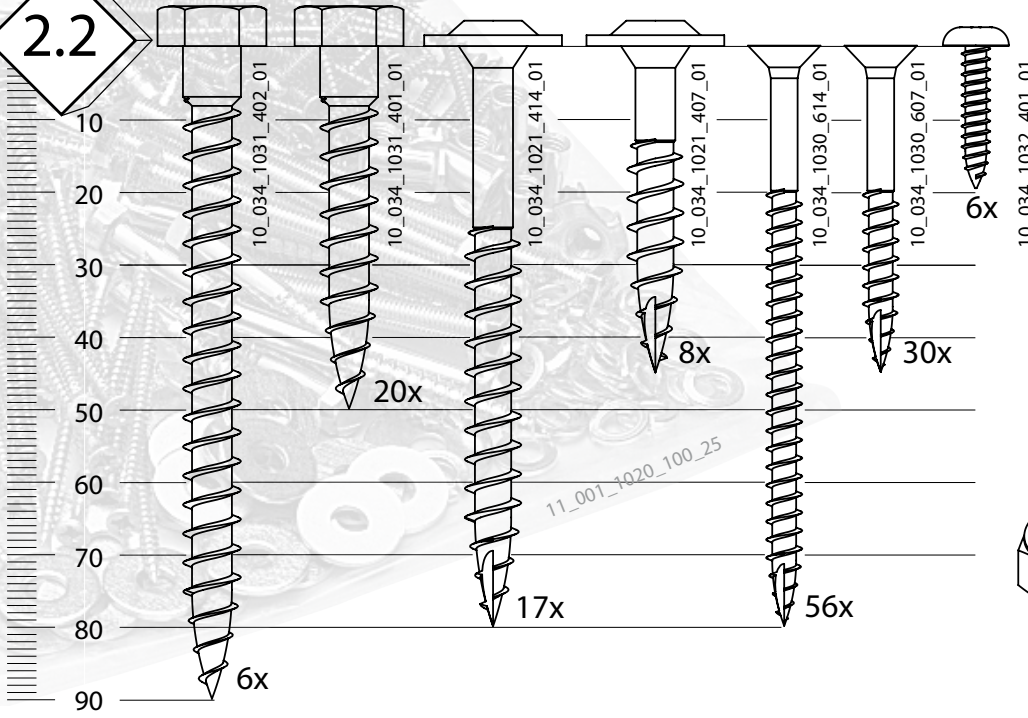

...	1	4x	4x	4x	4x	4x	4x
...	2	3x	4x	3x	3x	1x	3x
...	3	4x	6x	4x	4x	2x	4x
...	4	1x	1x	1x	1x	1x	1x

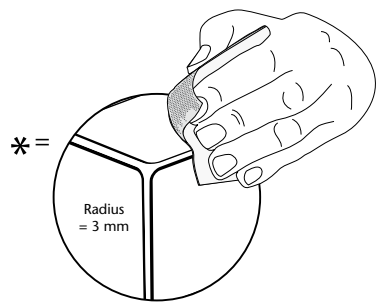

3.1

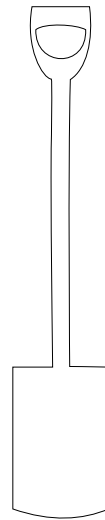
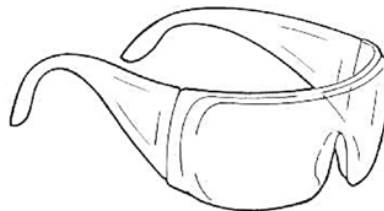
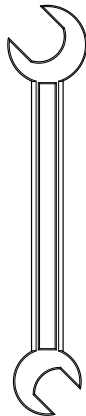
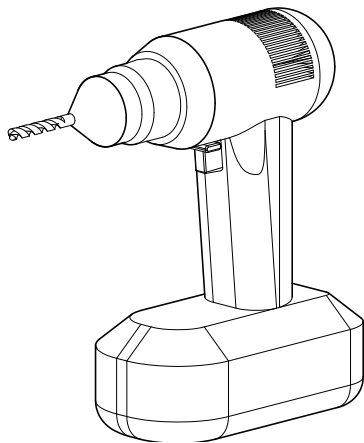
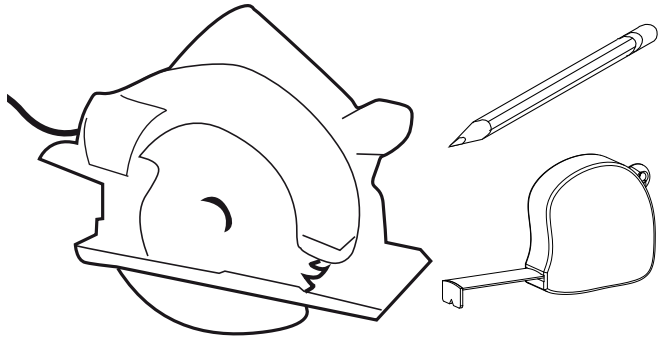
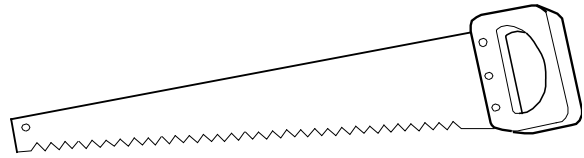
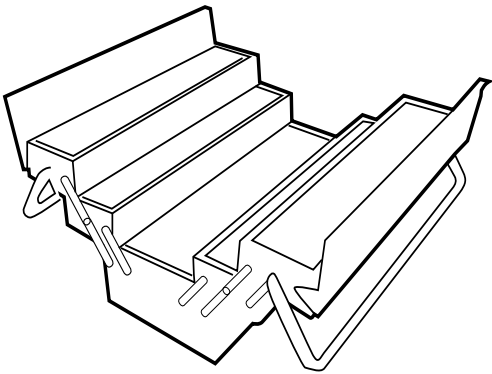

3.2

80mm

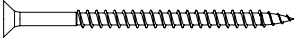

45mm

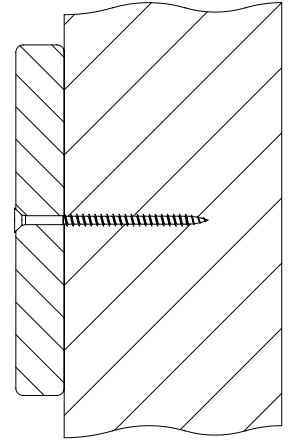
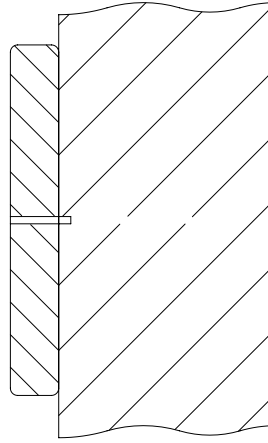
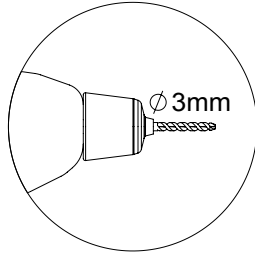
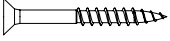

80mm

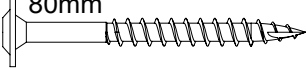

80mm

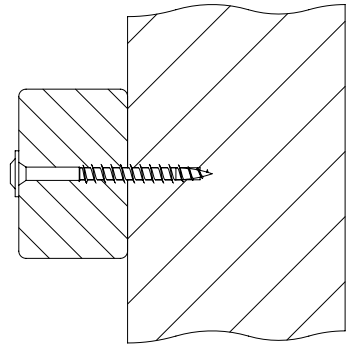
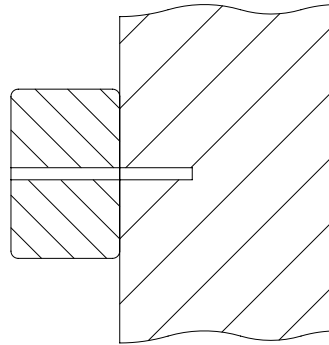
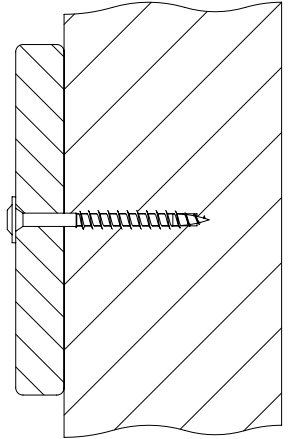
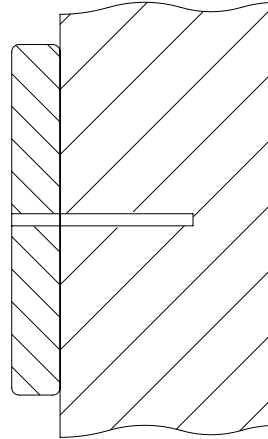
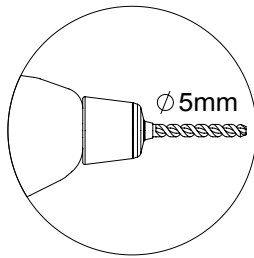
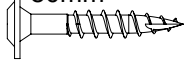

90mm

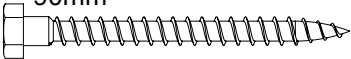

90mm

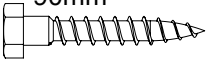

80mm

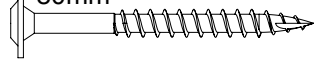

80mm

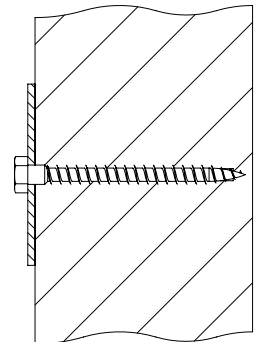
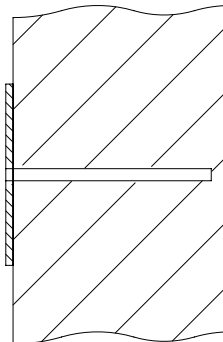
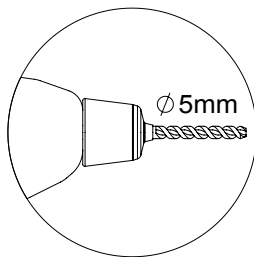
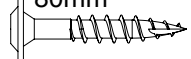

4.1'

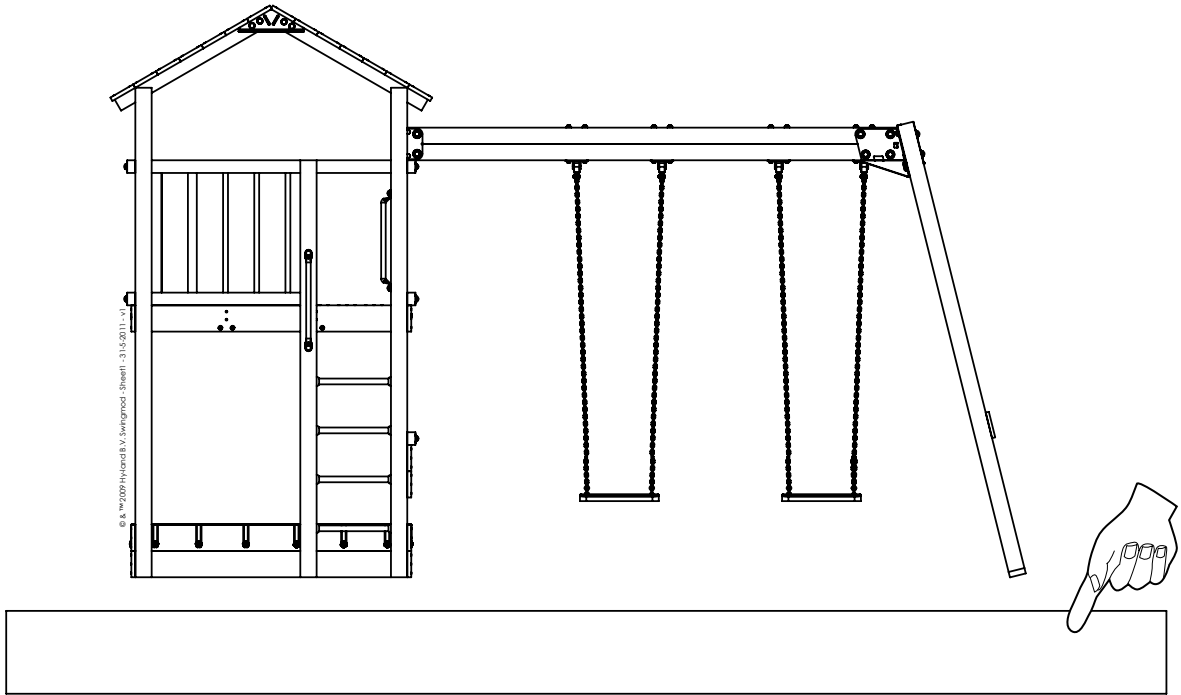

4.1''

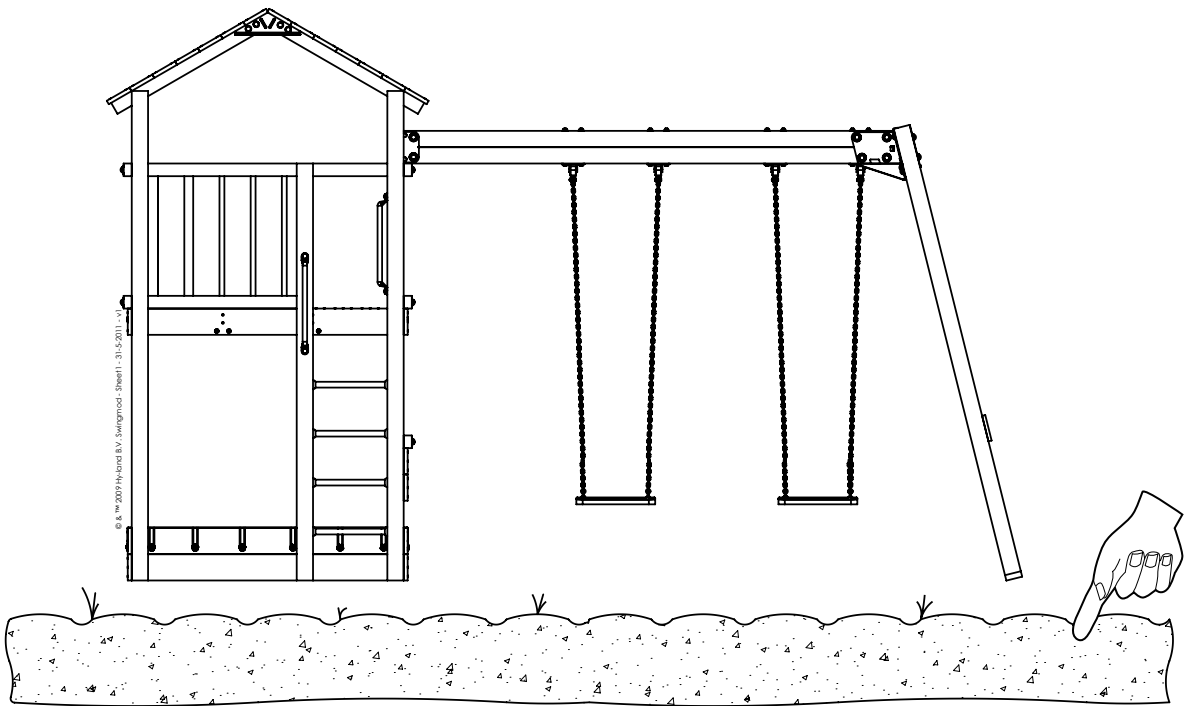



4.1'

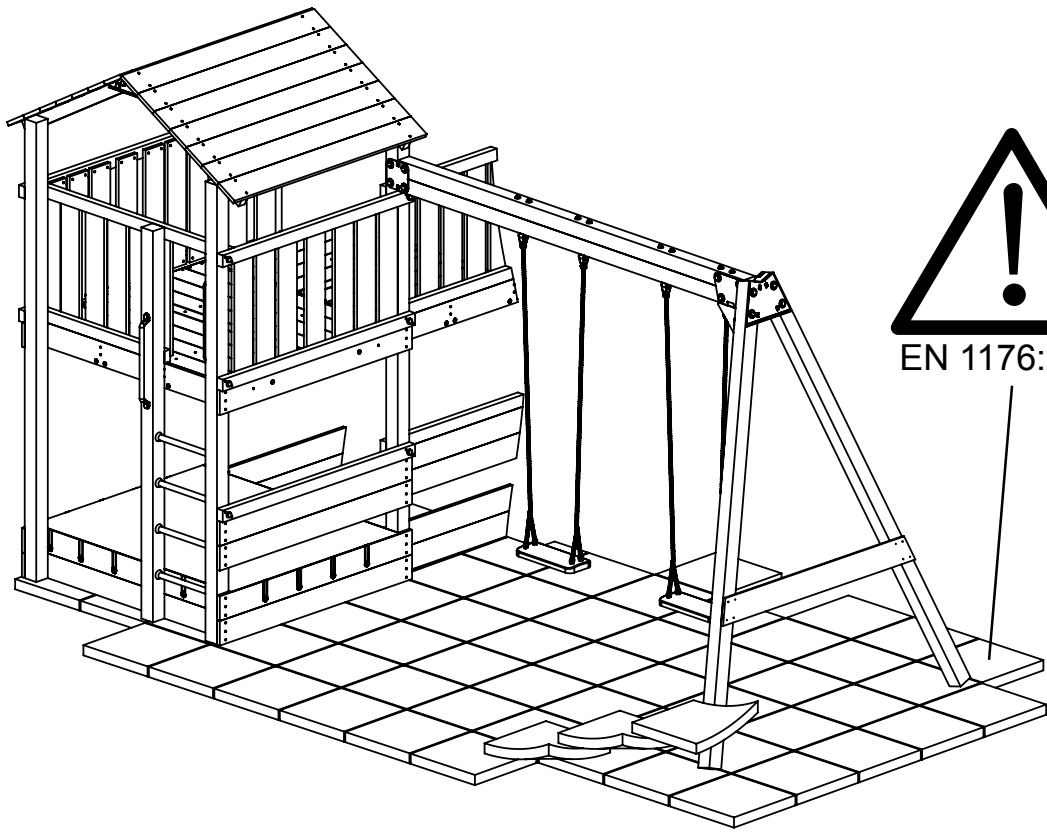

EN 1176:2008

4.1''

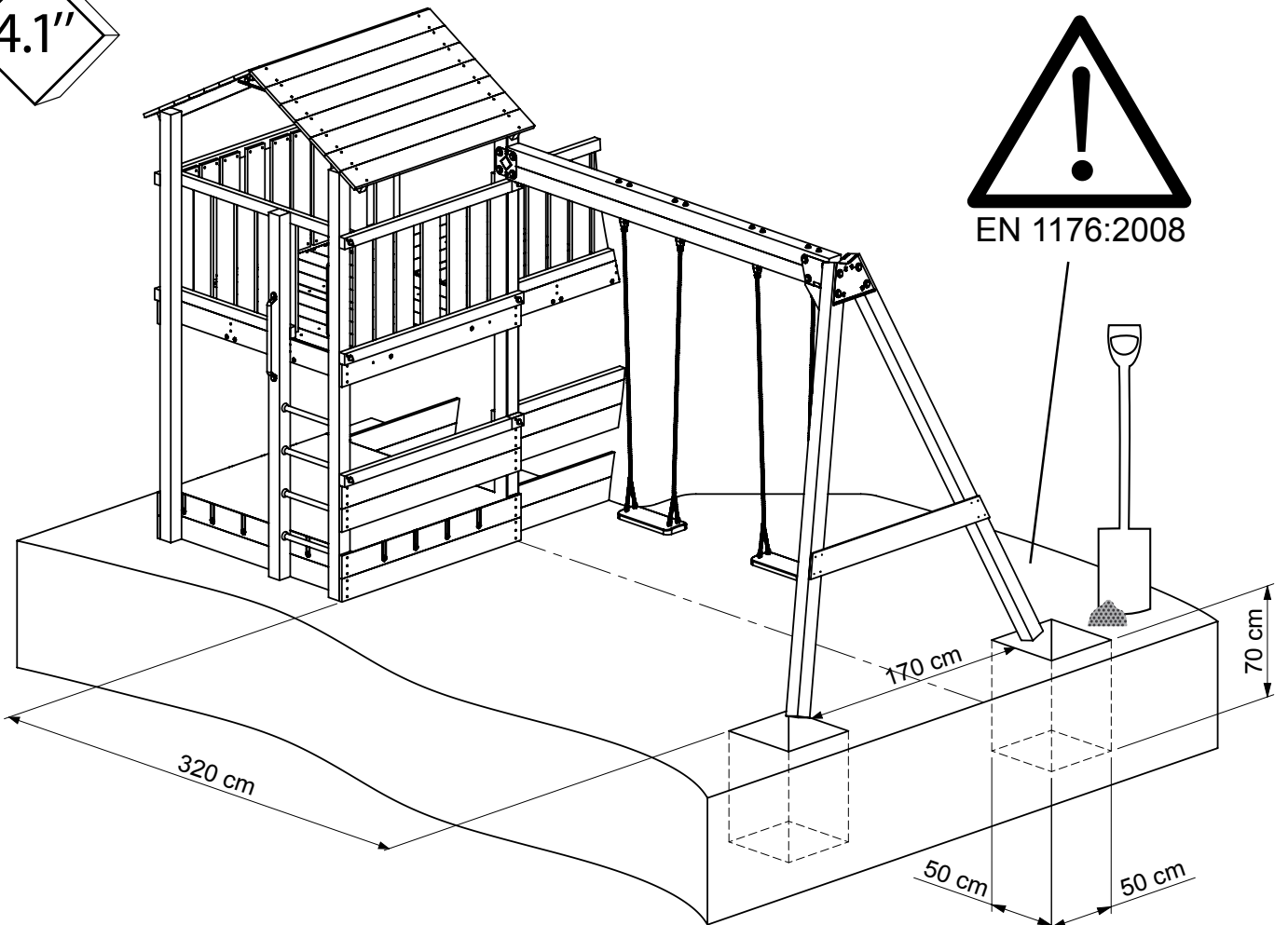

EN 1176:2008

4

3s

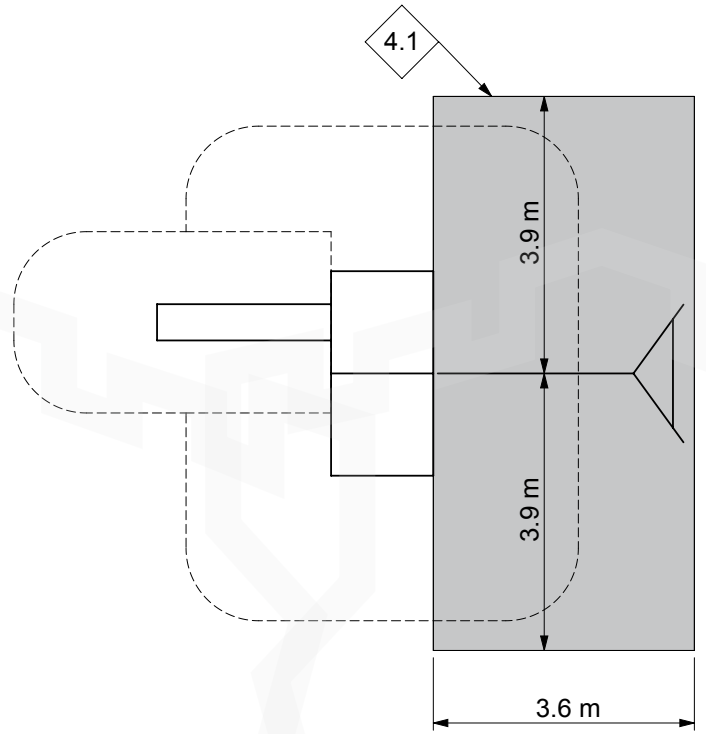
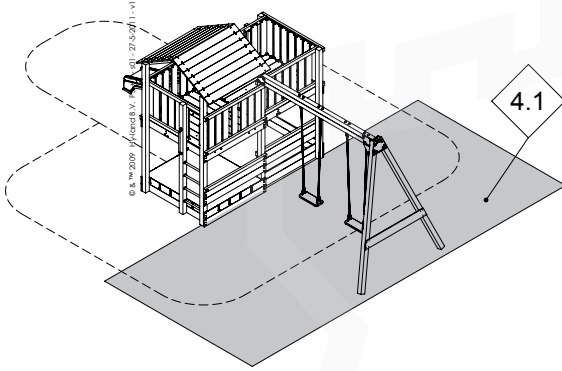

5s

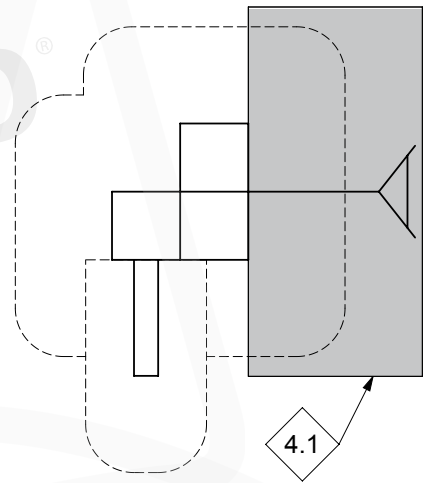
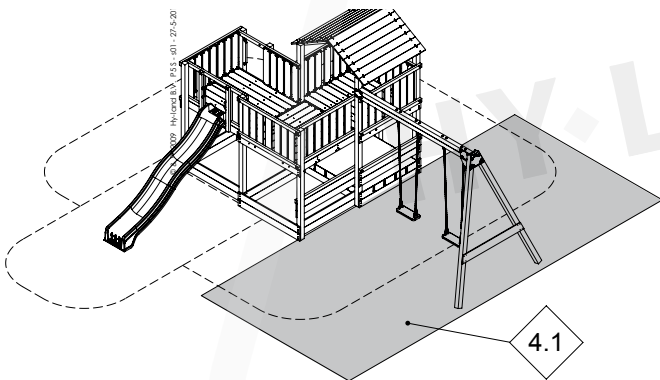

7s

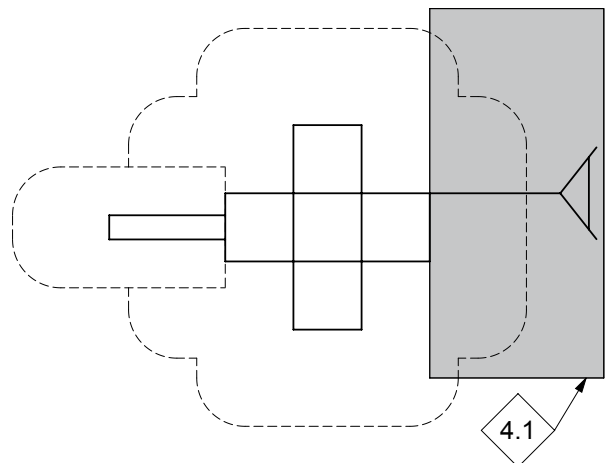
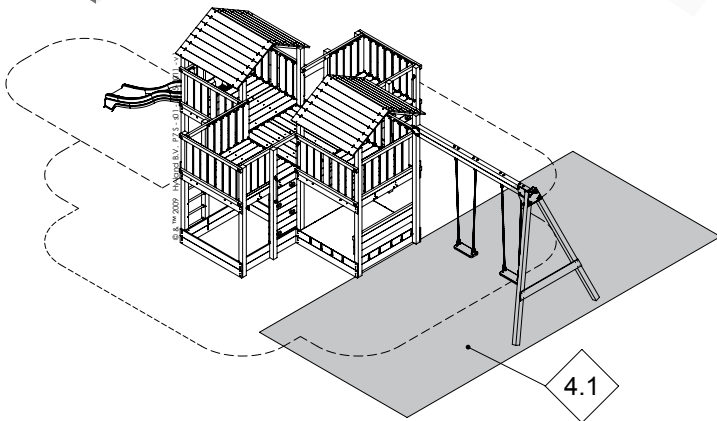

4s

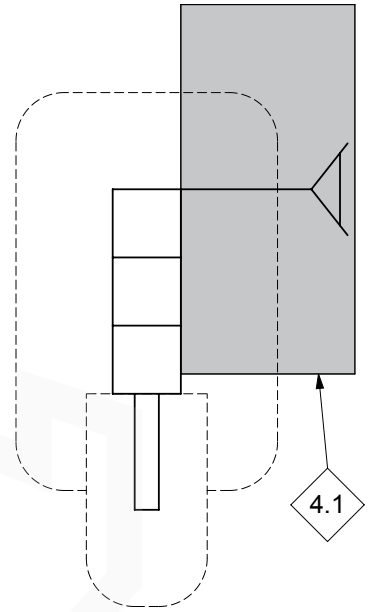
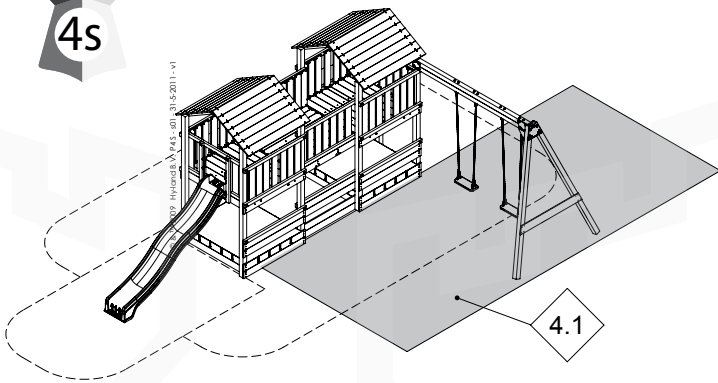

6s

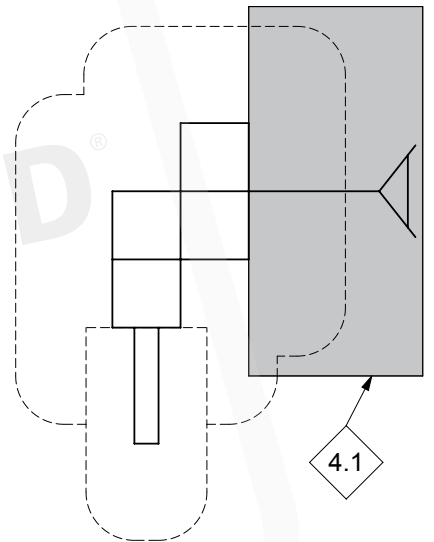
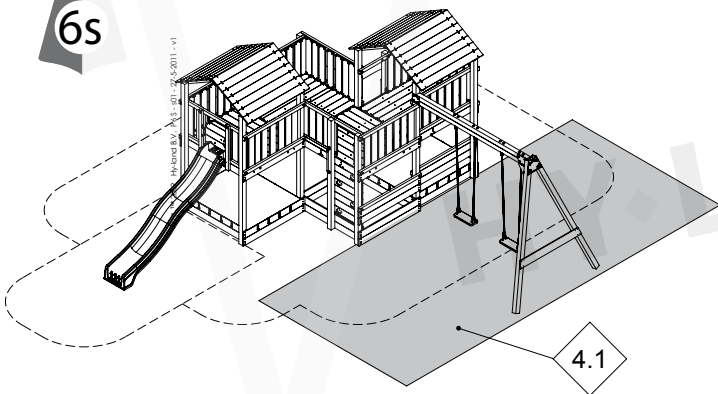

8s

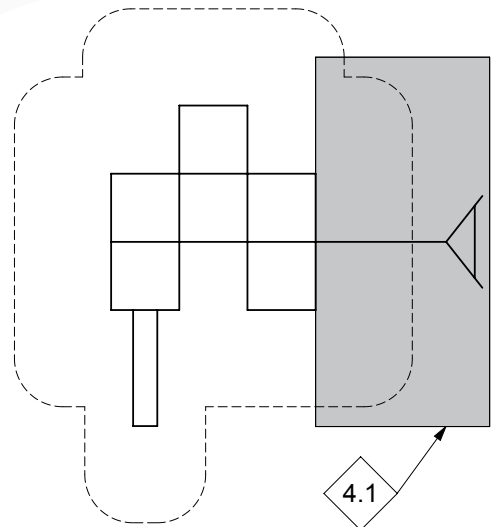
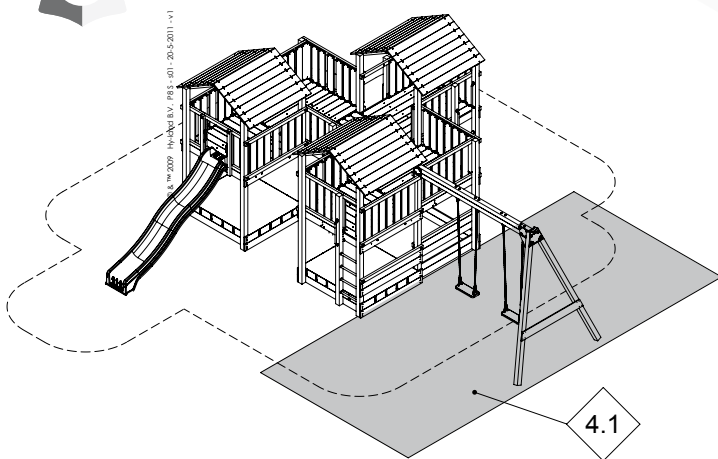

5

3s

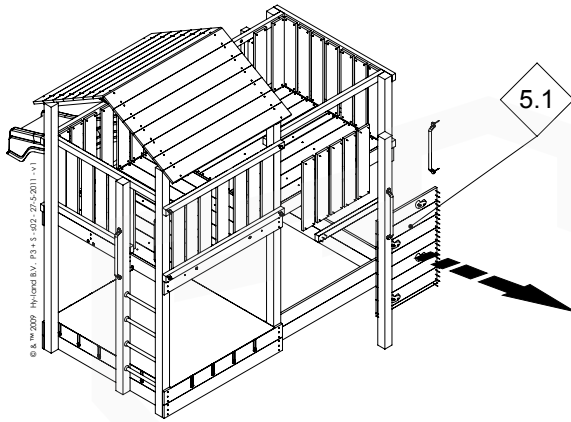

5s

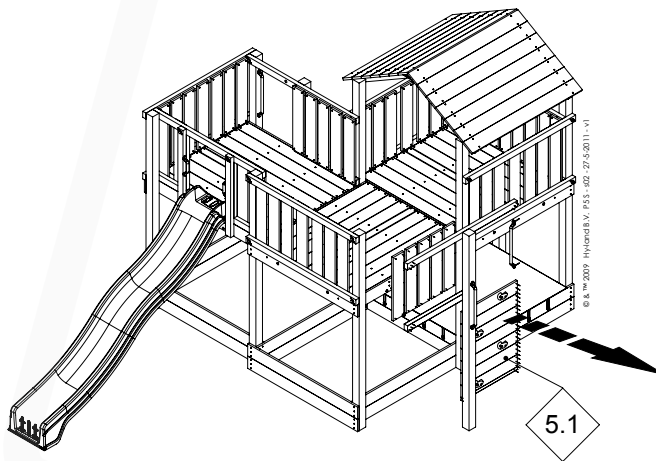

7s

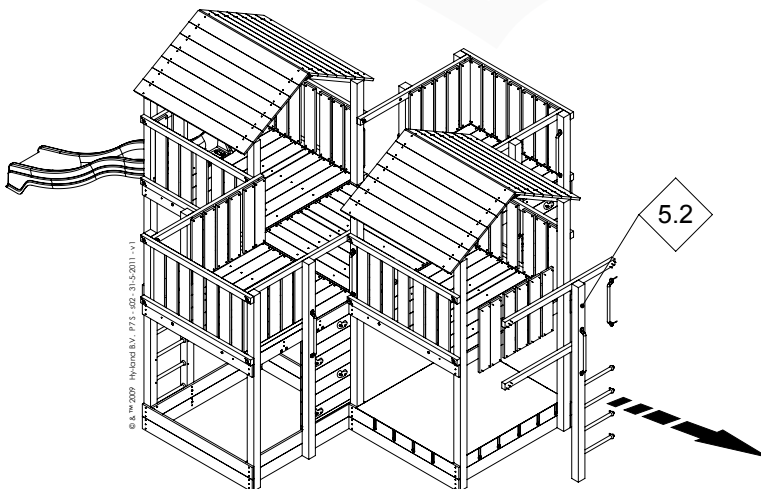

4s

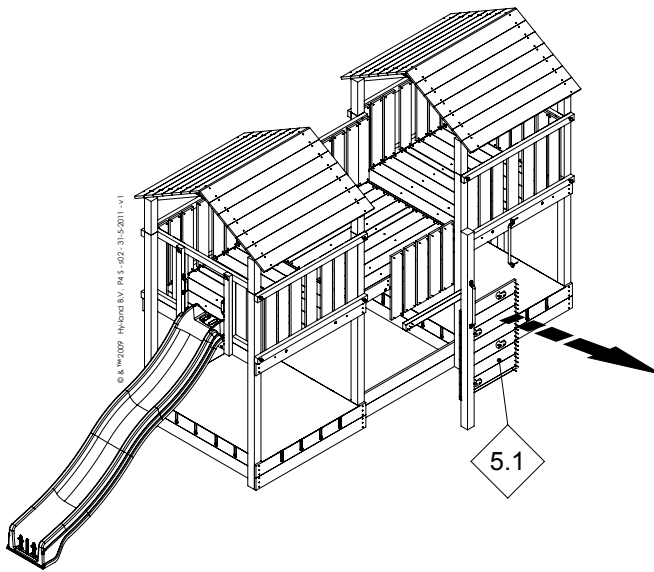

6s

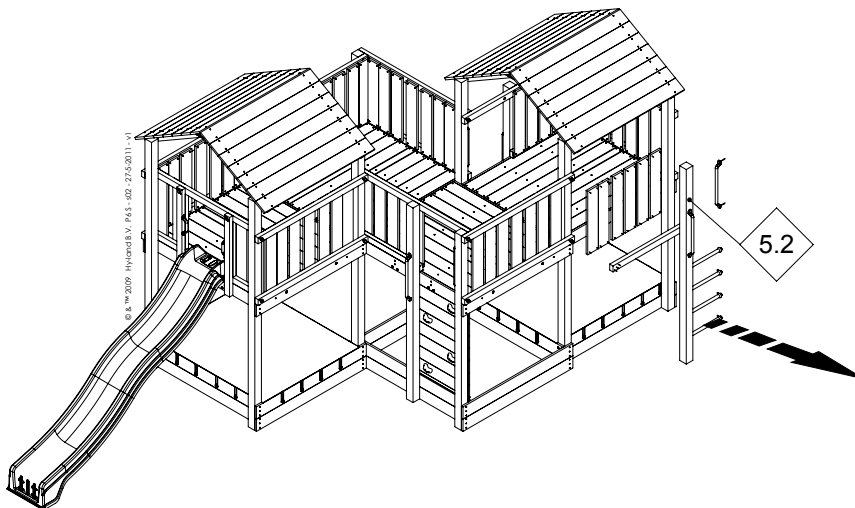

8s

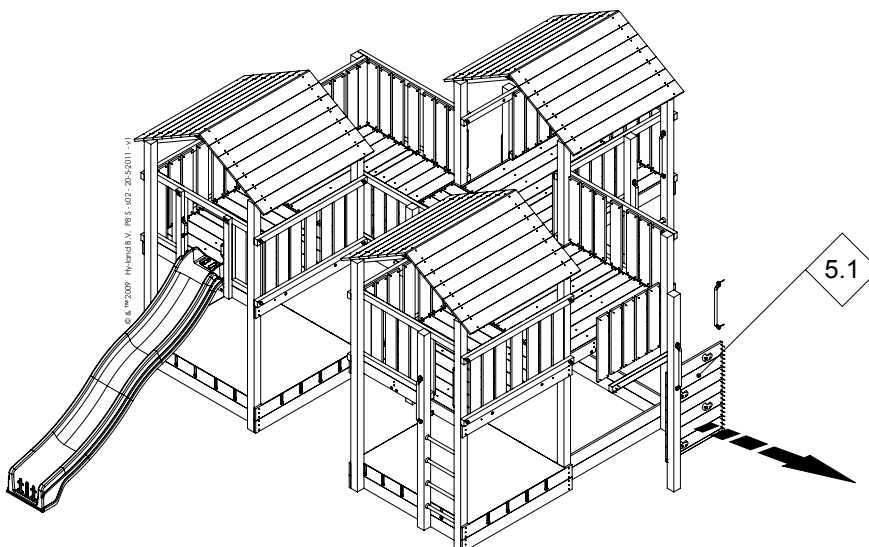

5.1

Paginaverwijzing p 19

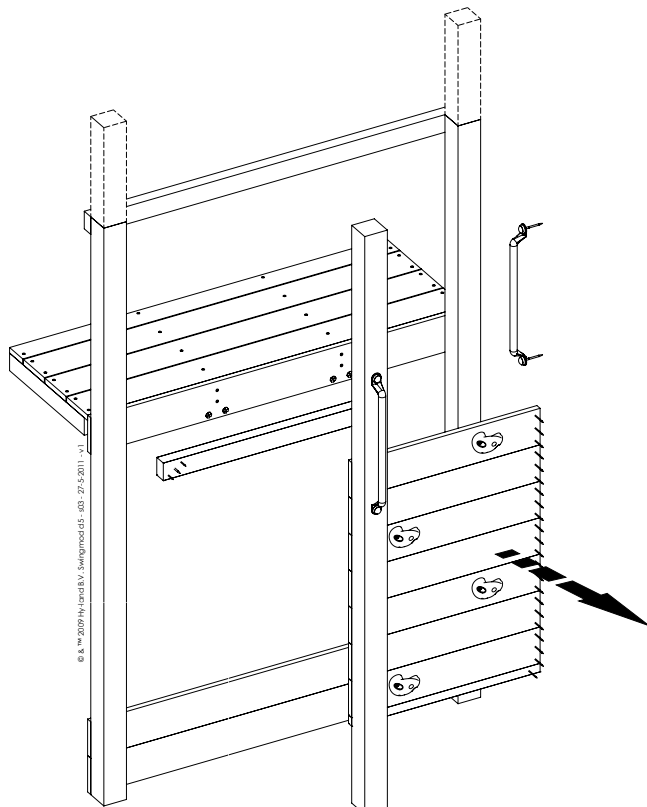
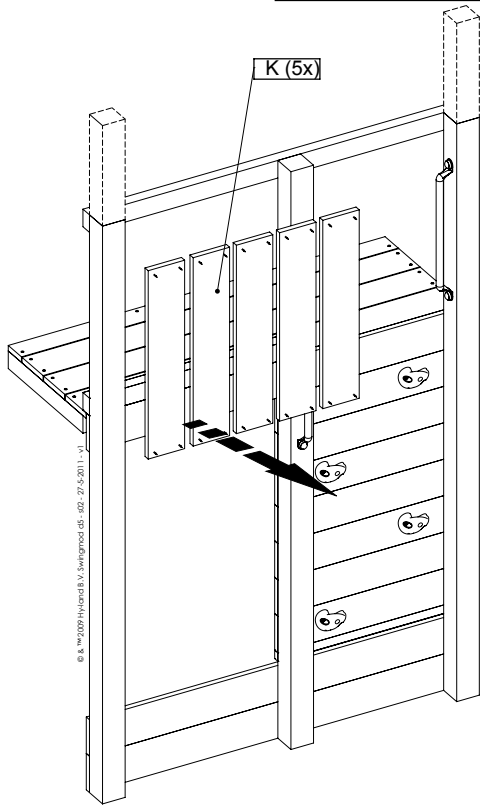

5.2

Paginaverwijzing p 19

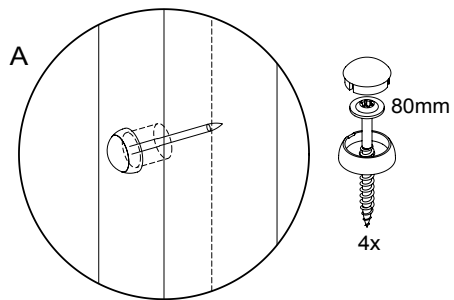
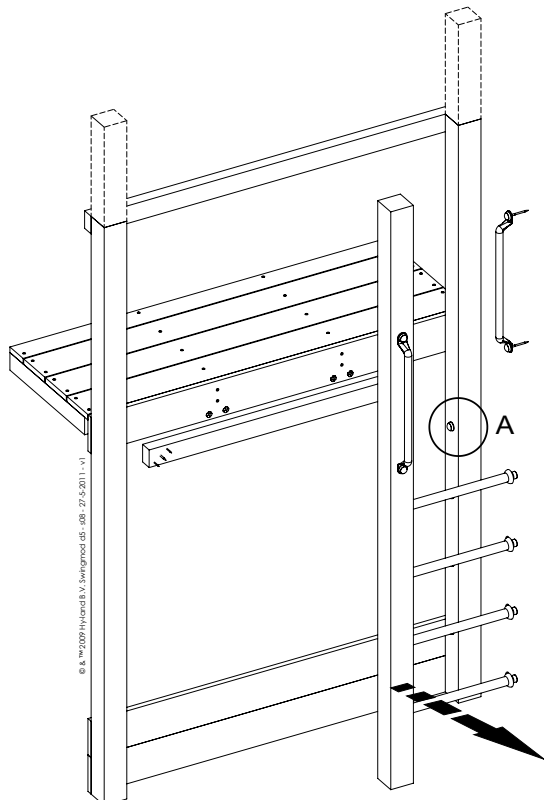
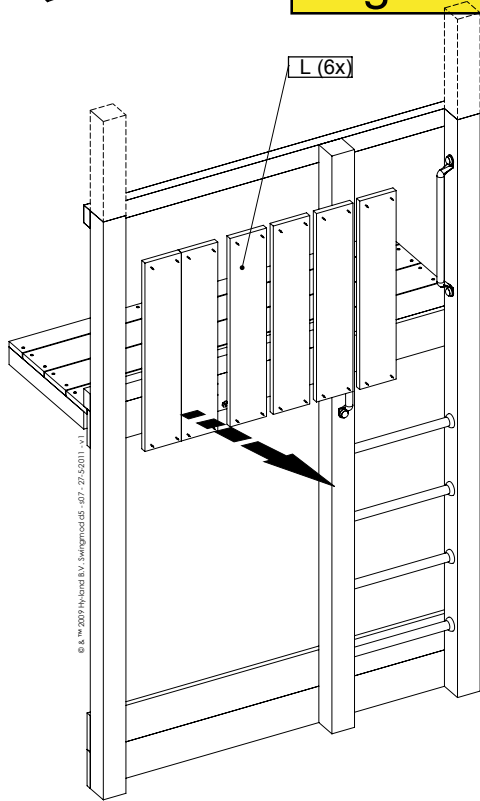

6

3s

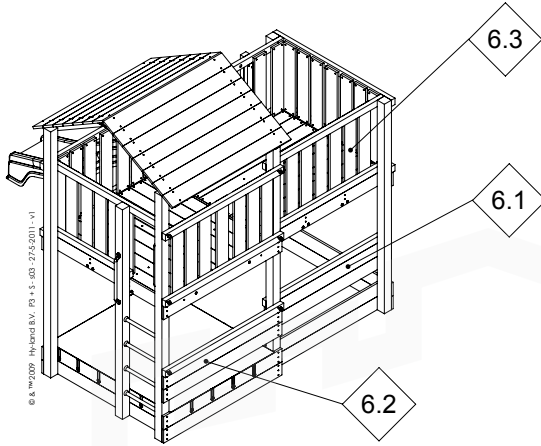

5s

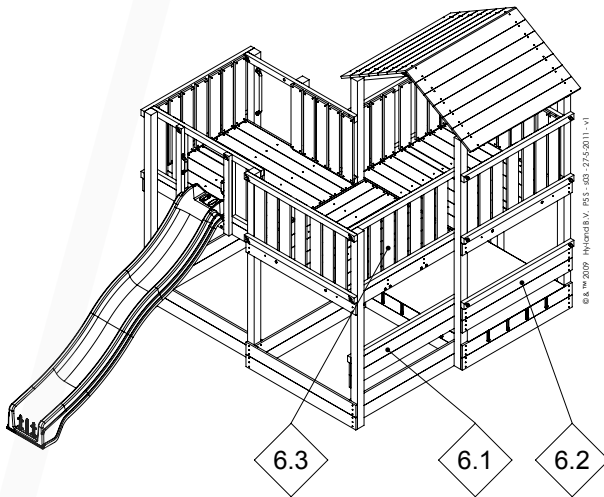

7s

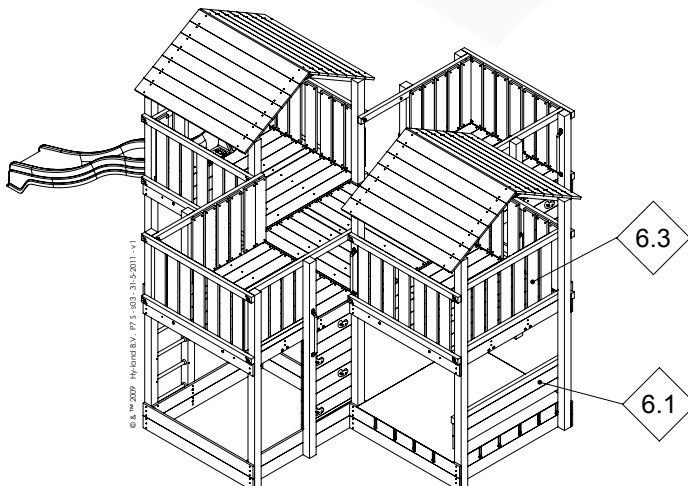



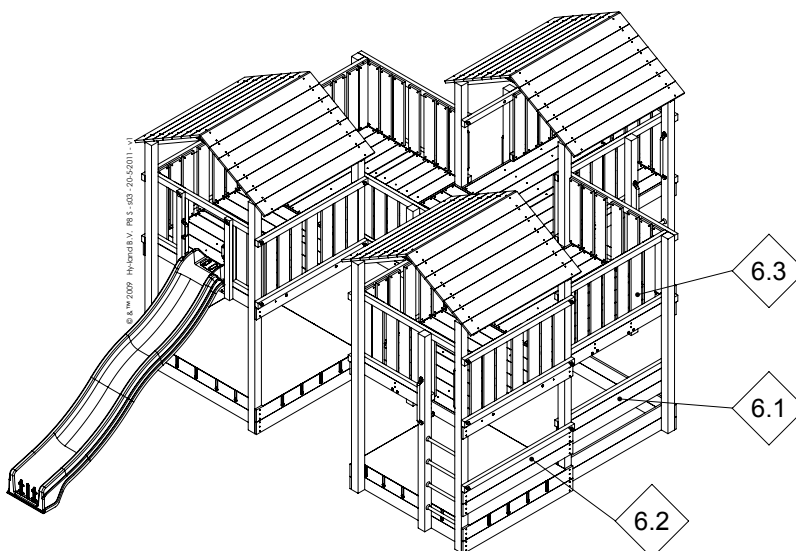
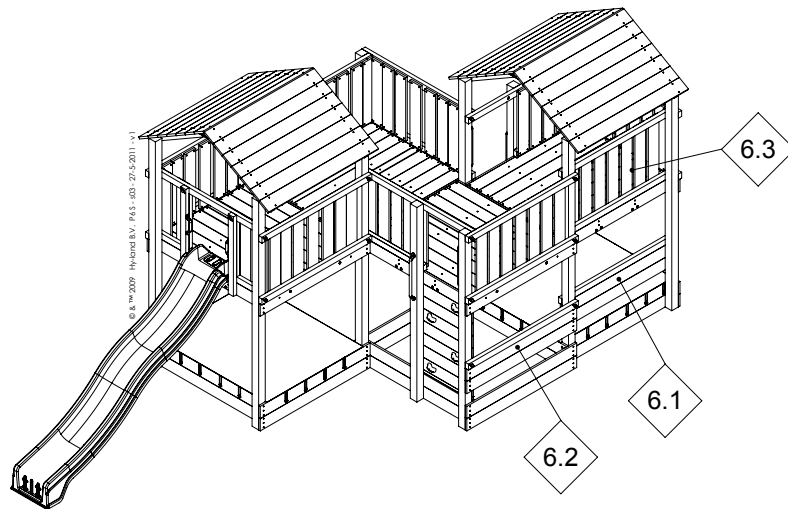
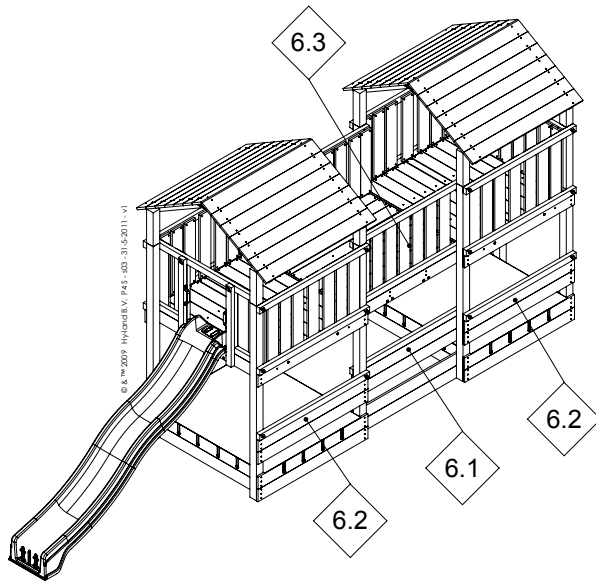

# 6.1

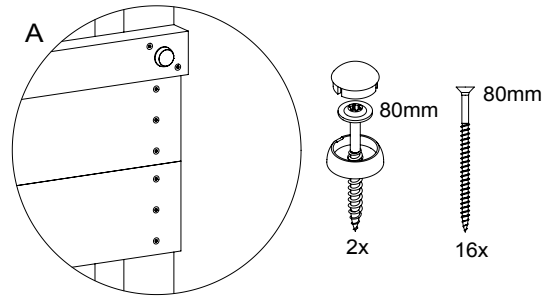
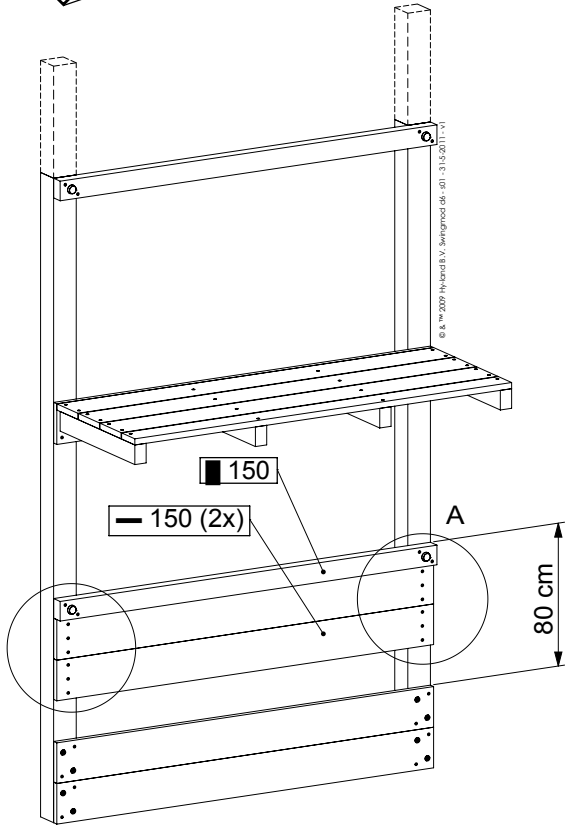

# 6.2

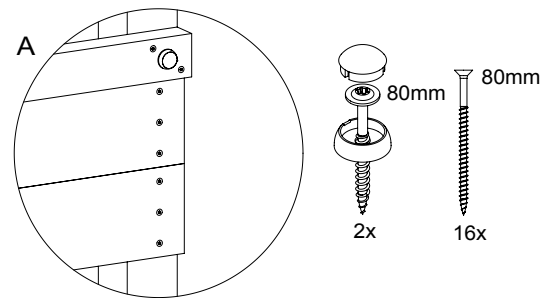
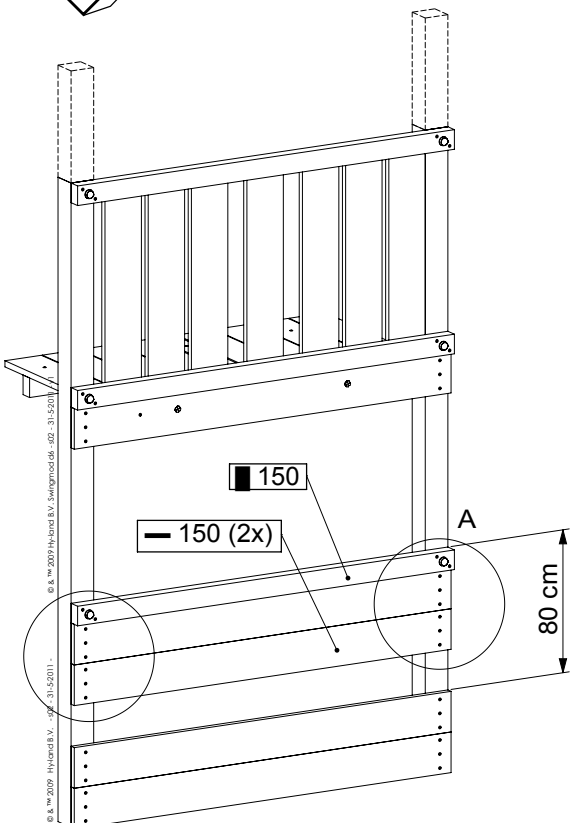

# 6.3

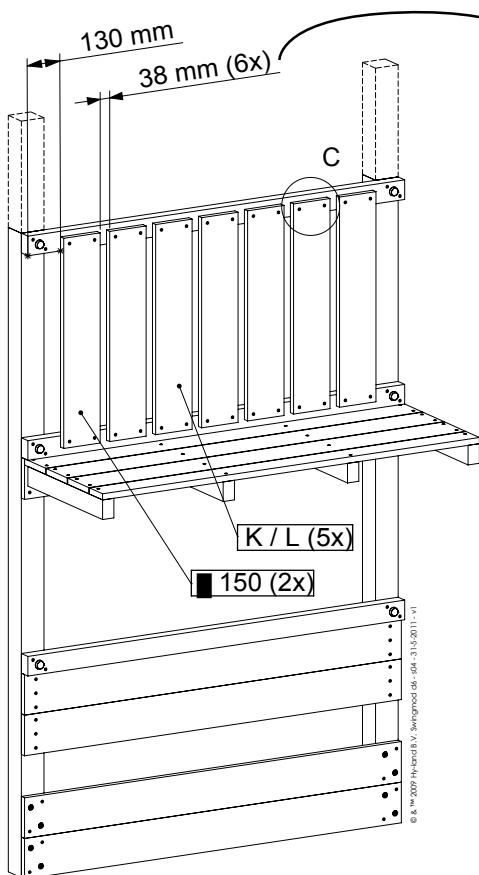
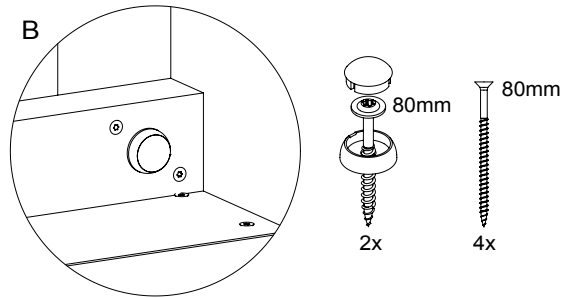
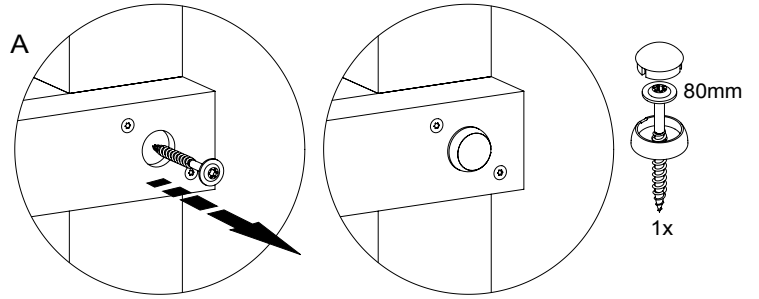
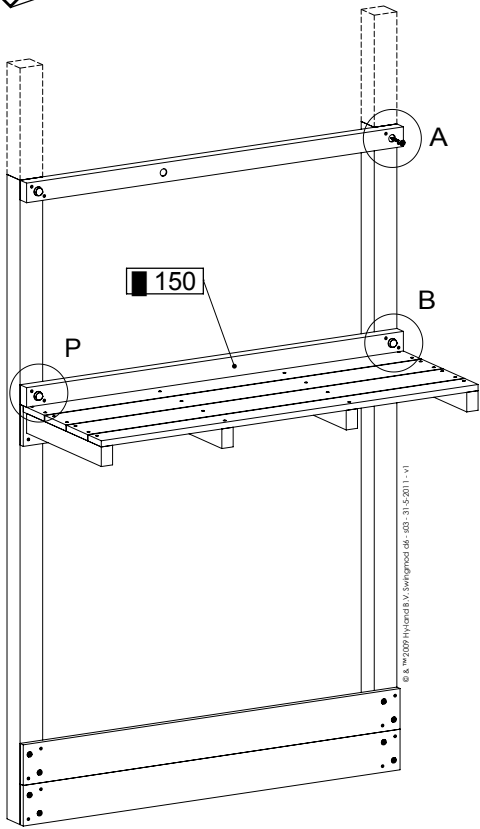

10\_030\_5071\_110\_01

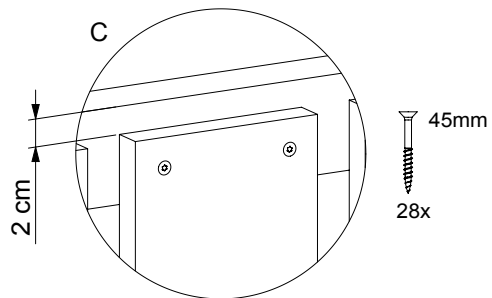

7

3s

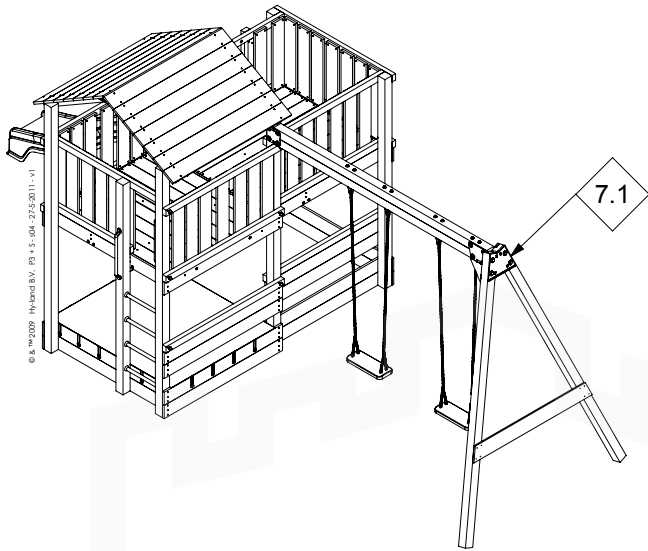

5s

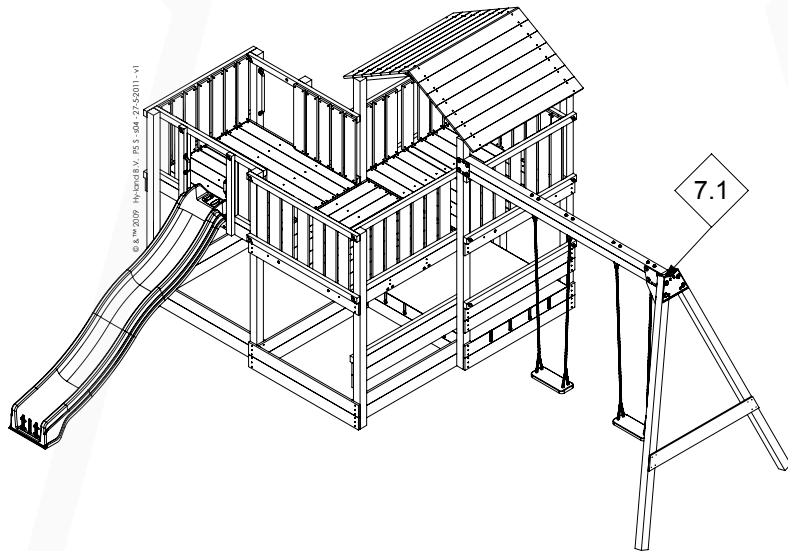

7s

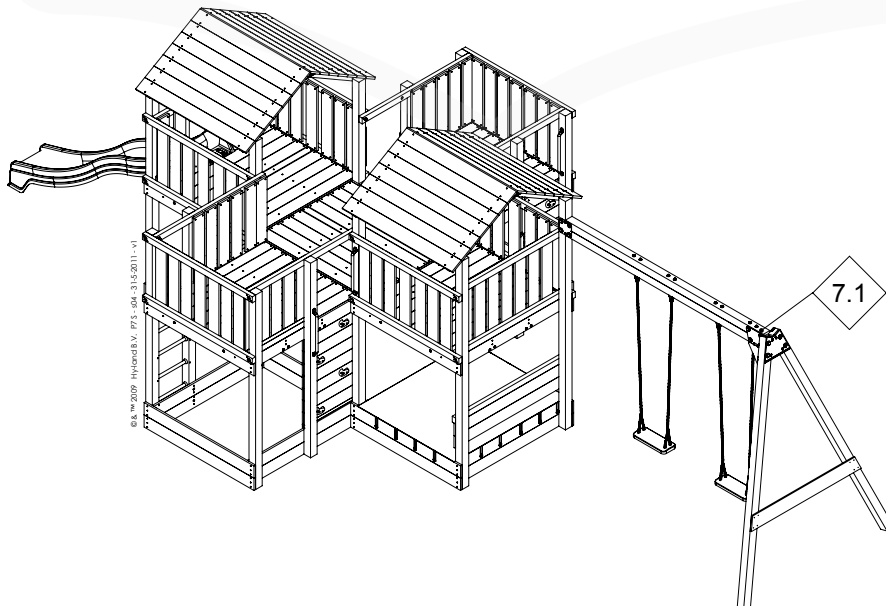

4s

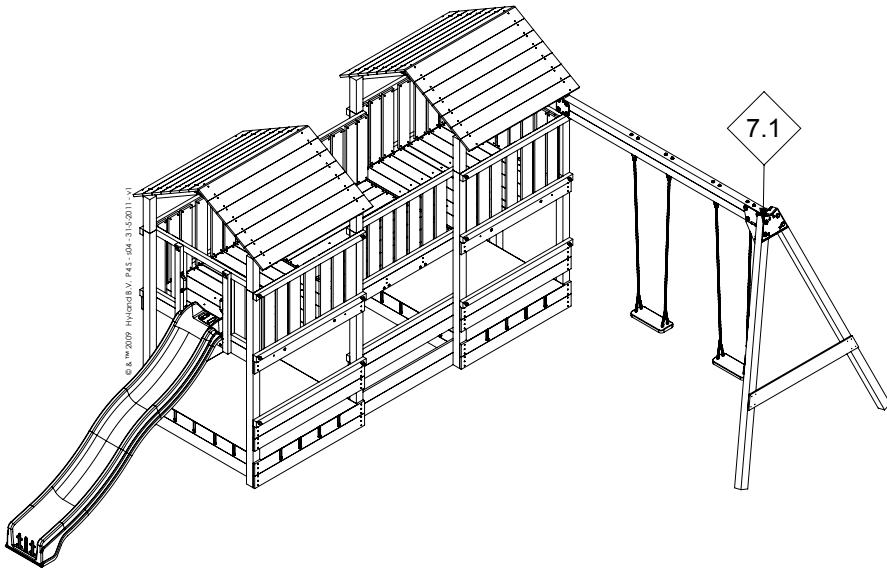

6s

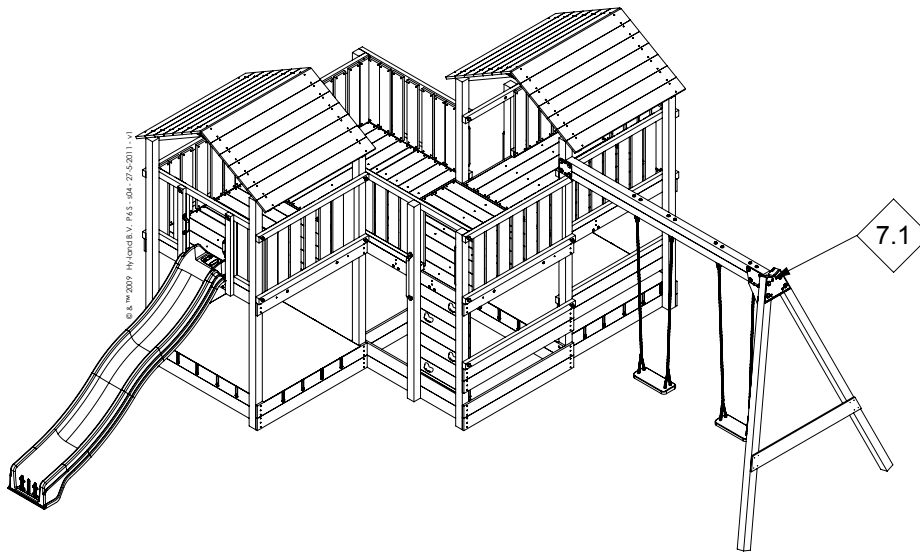

8s

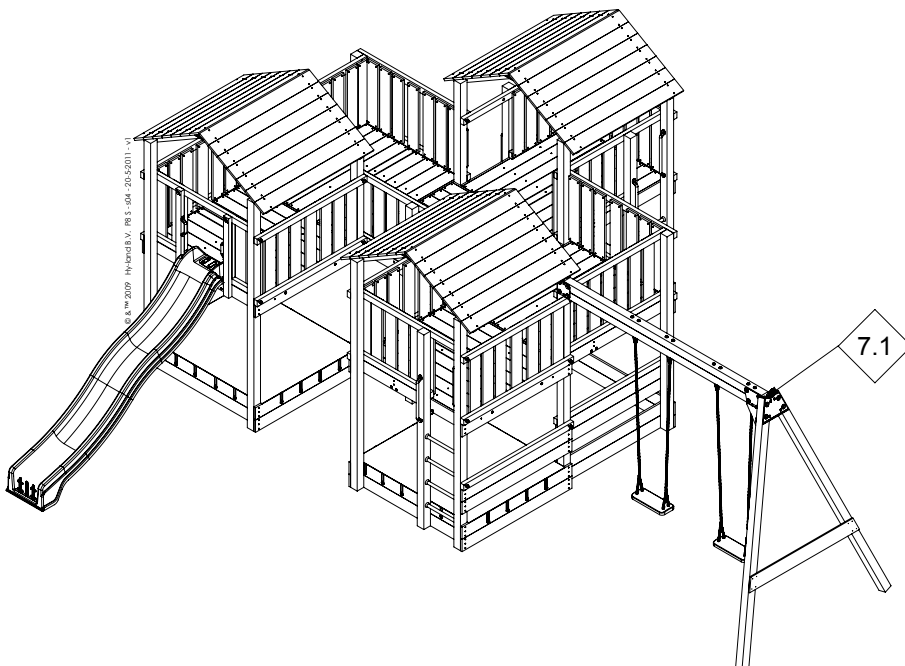

# 7.1a

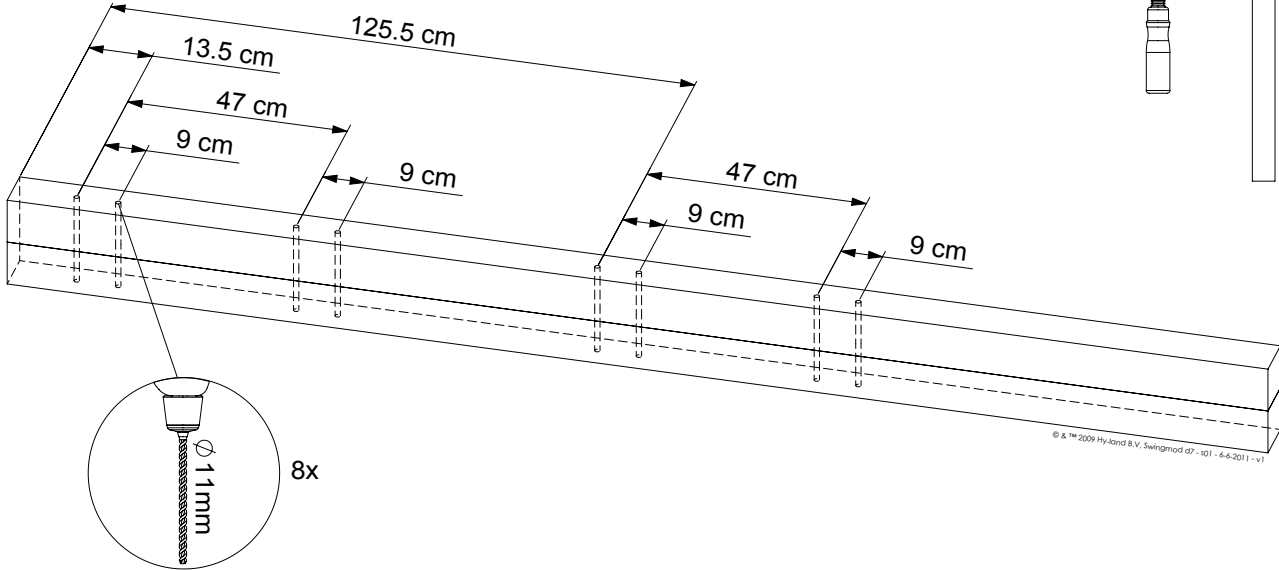
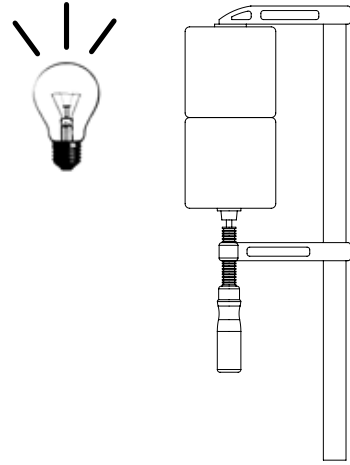

# 7.1b

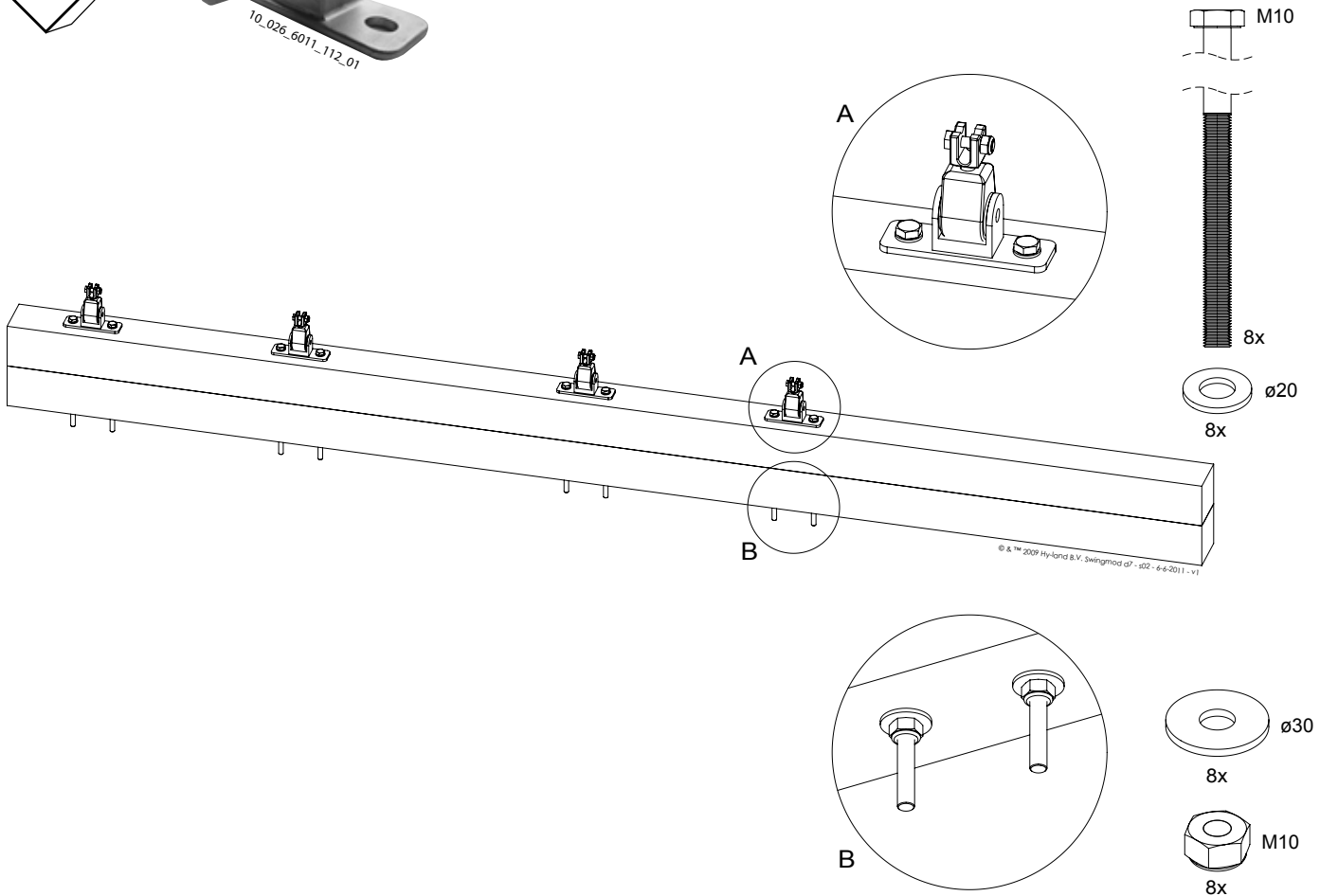
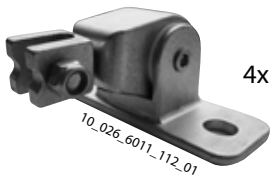

7.1c

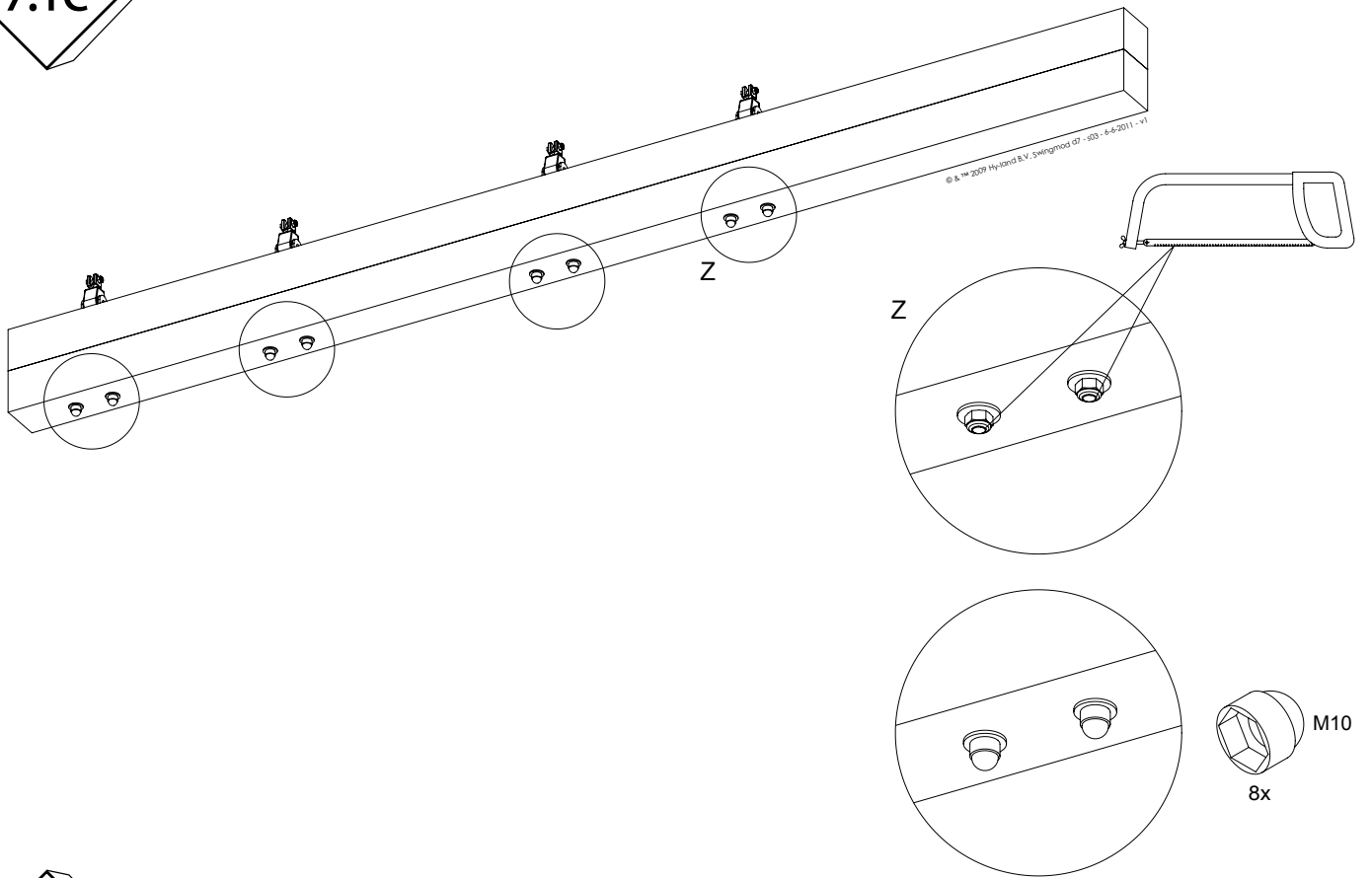

7.1d

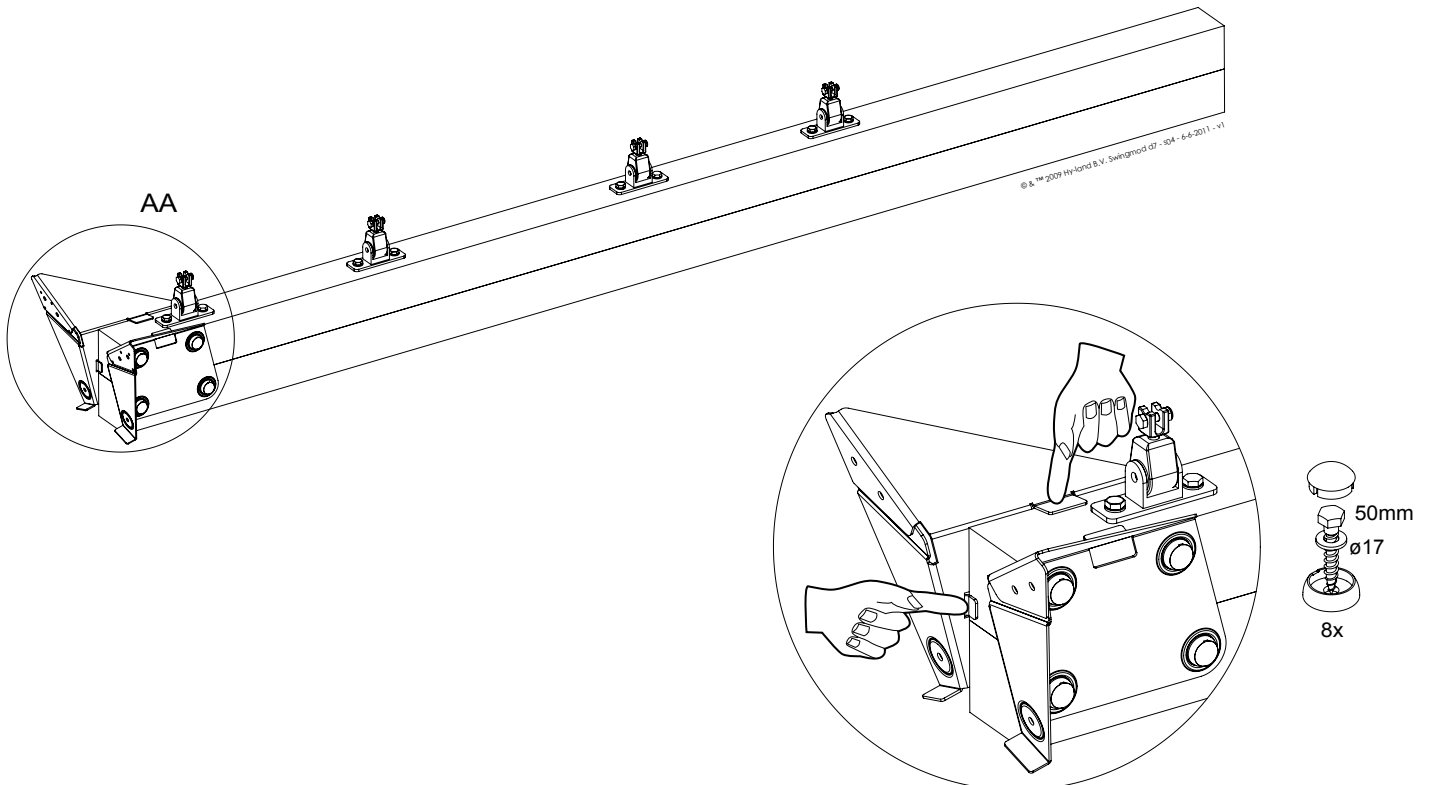
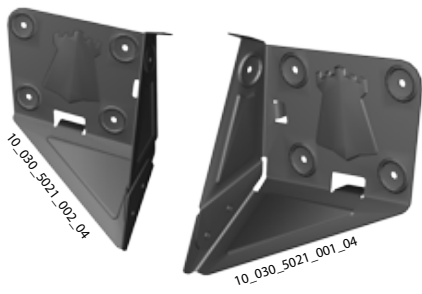

7.1e

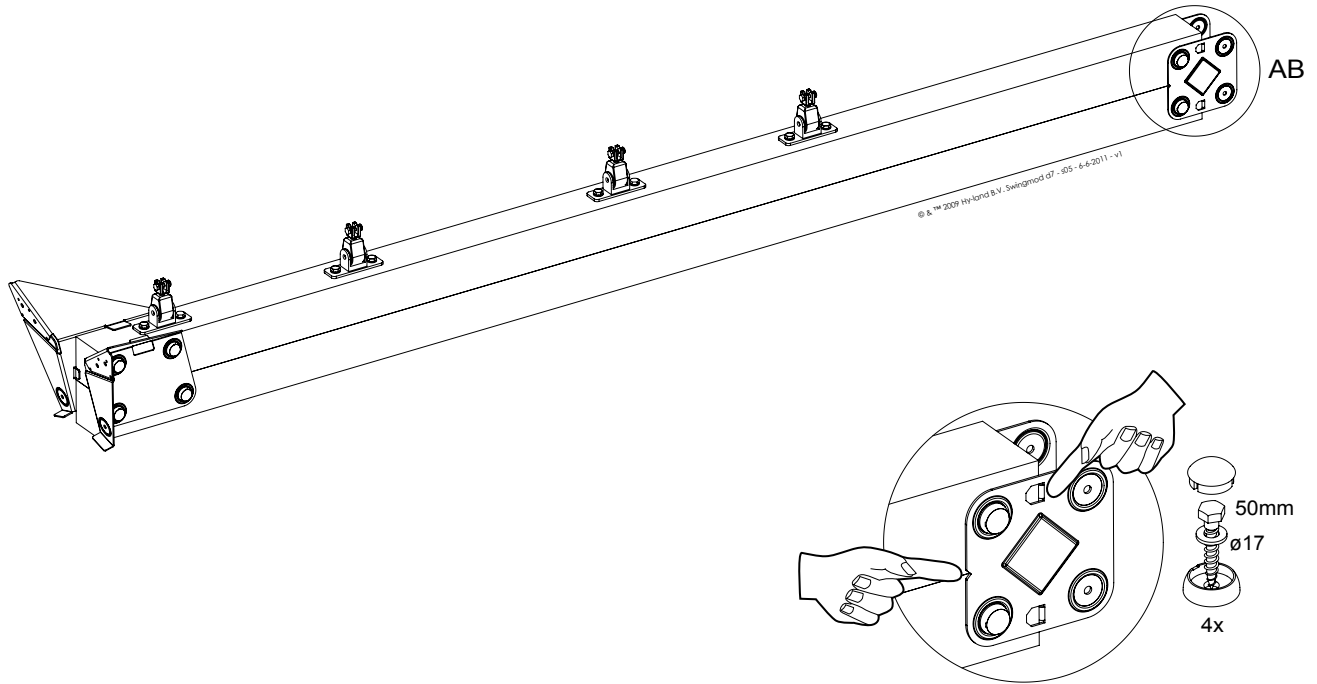
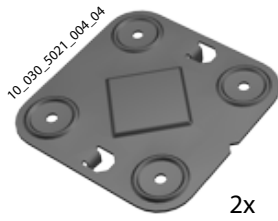

7.1f

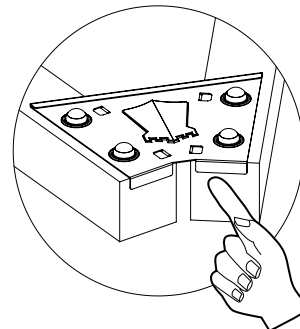
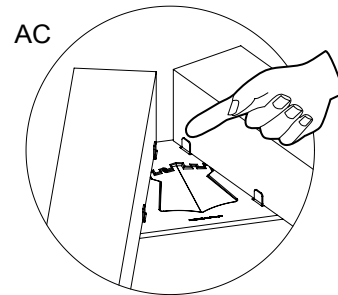
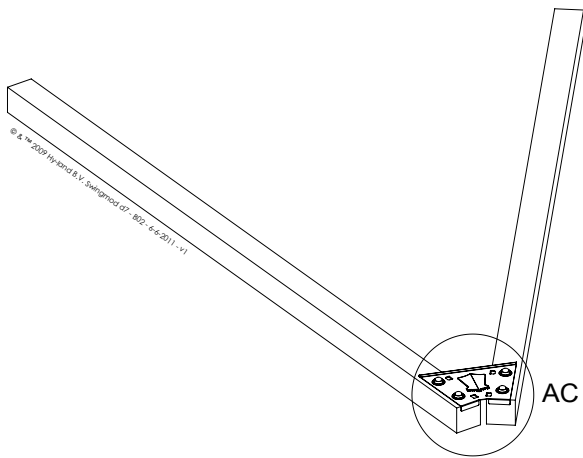
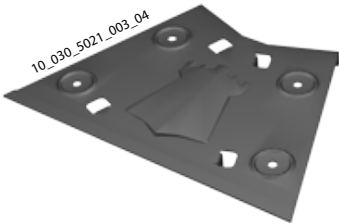



7.1g

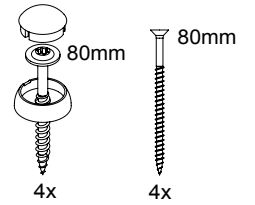
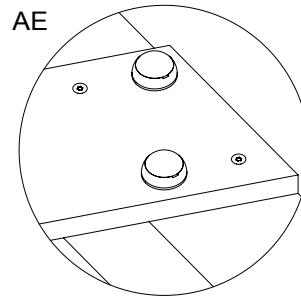
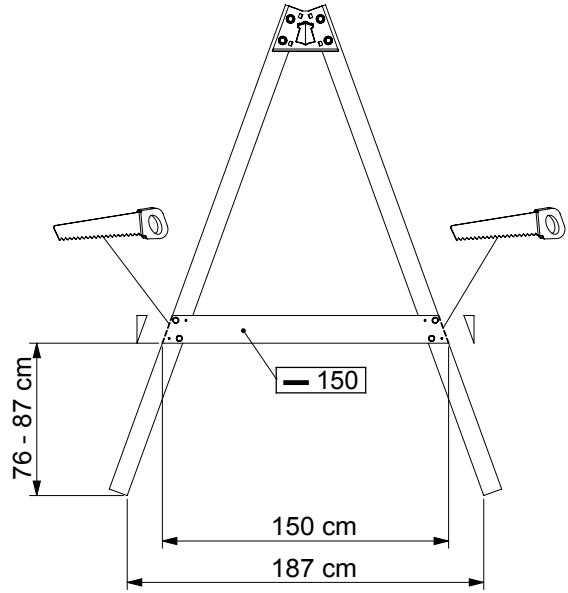
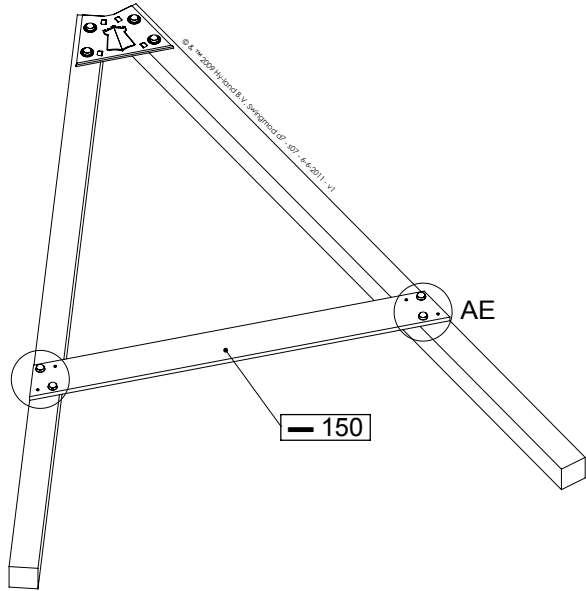

7.1h

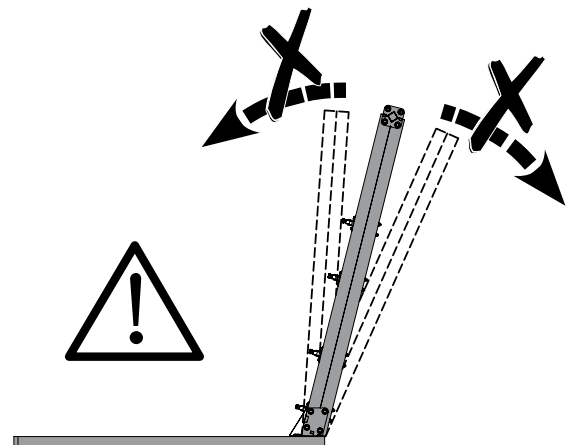
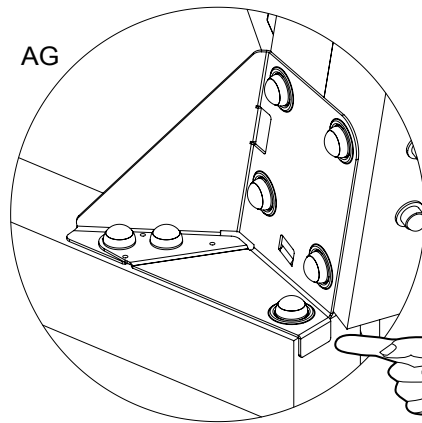
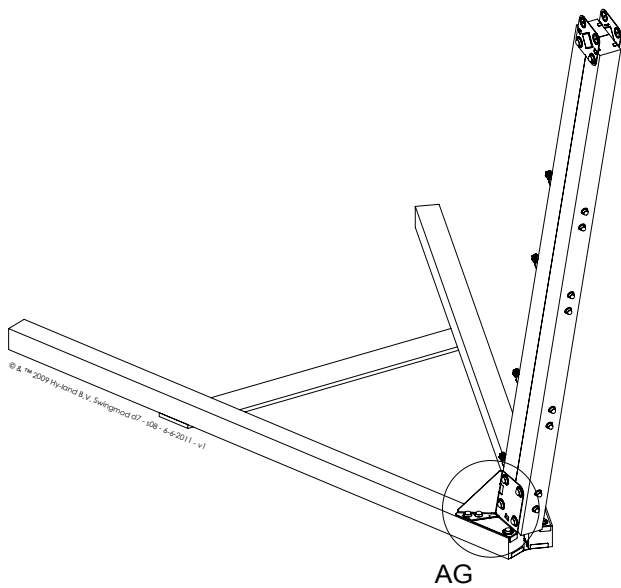

7.1i

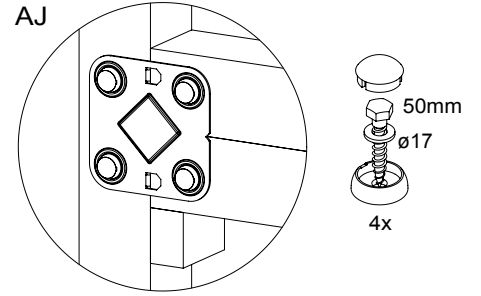
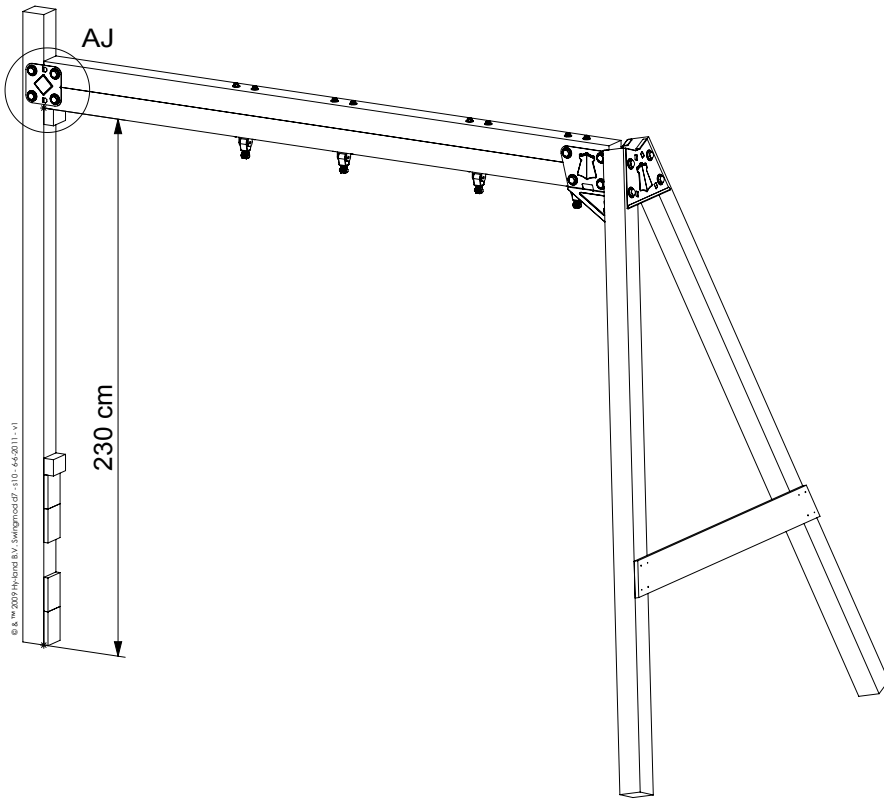

7.1j

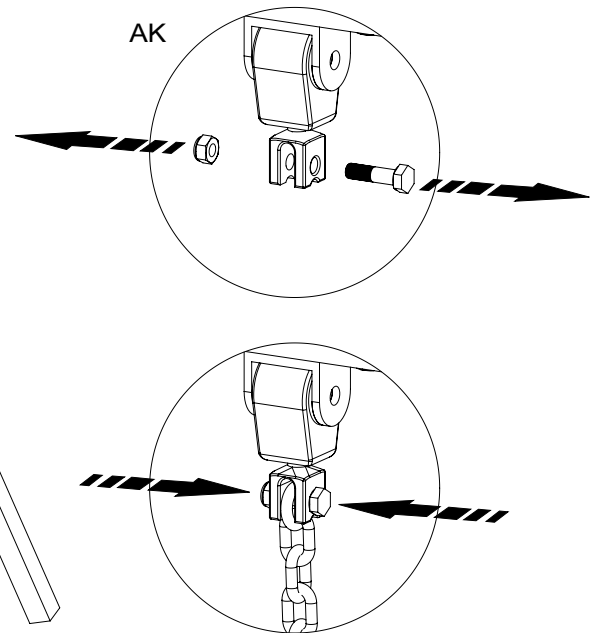
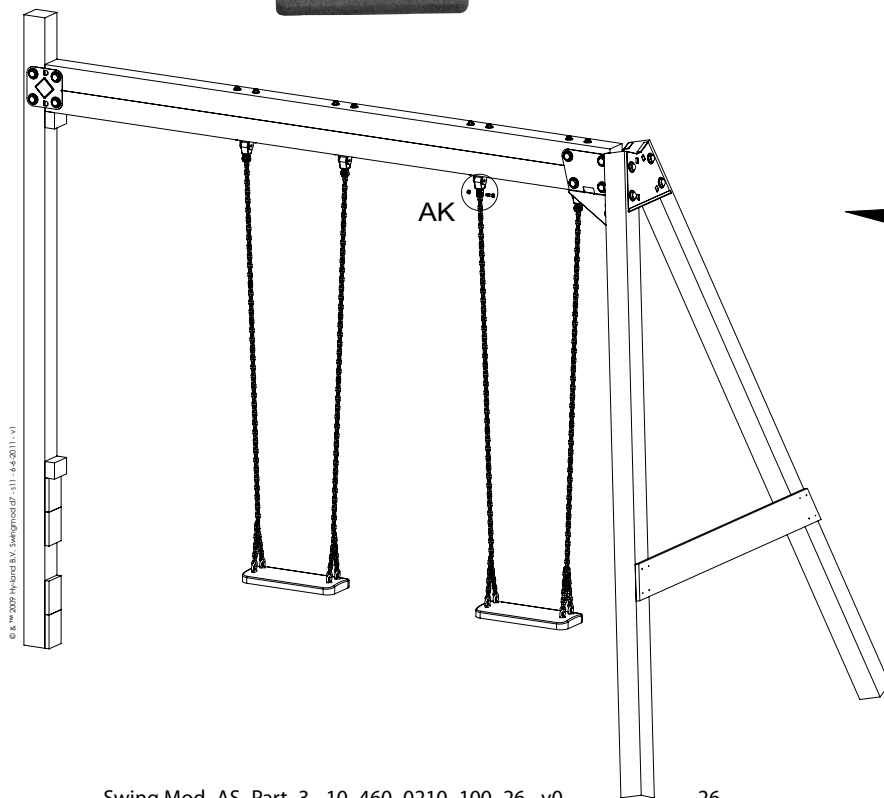
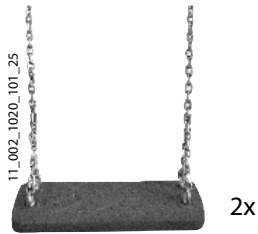

7.1k'

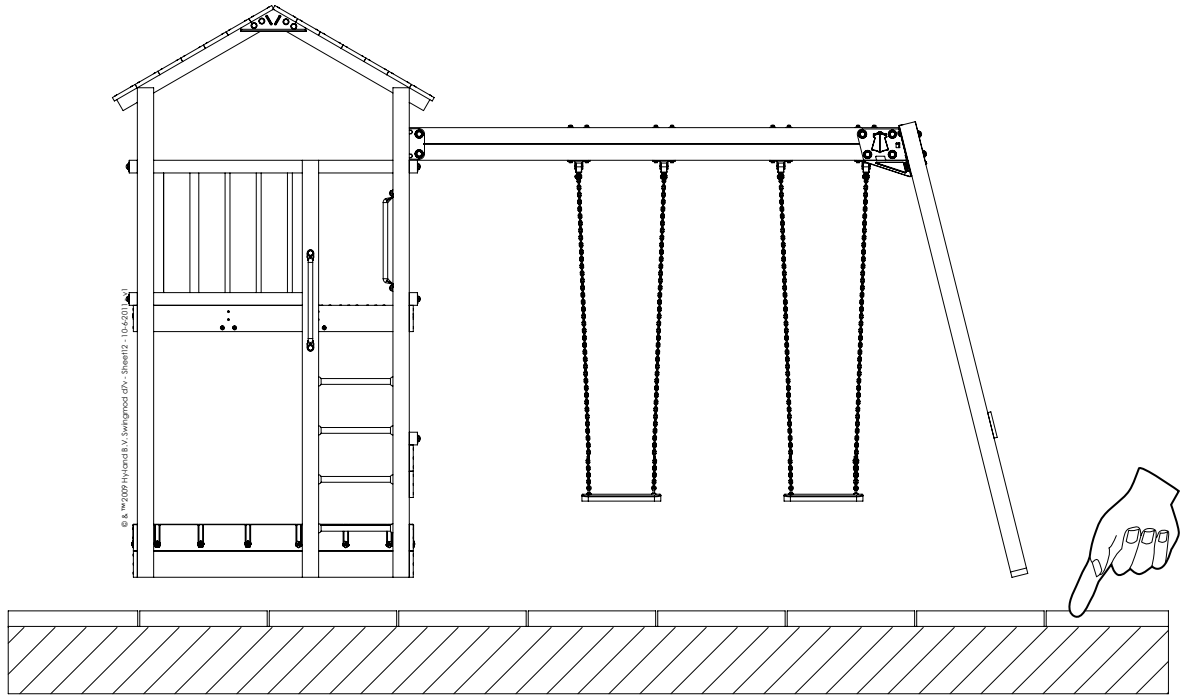

7.1k''

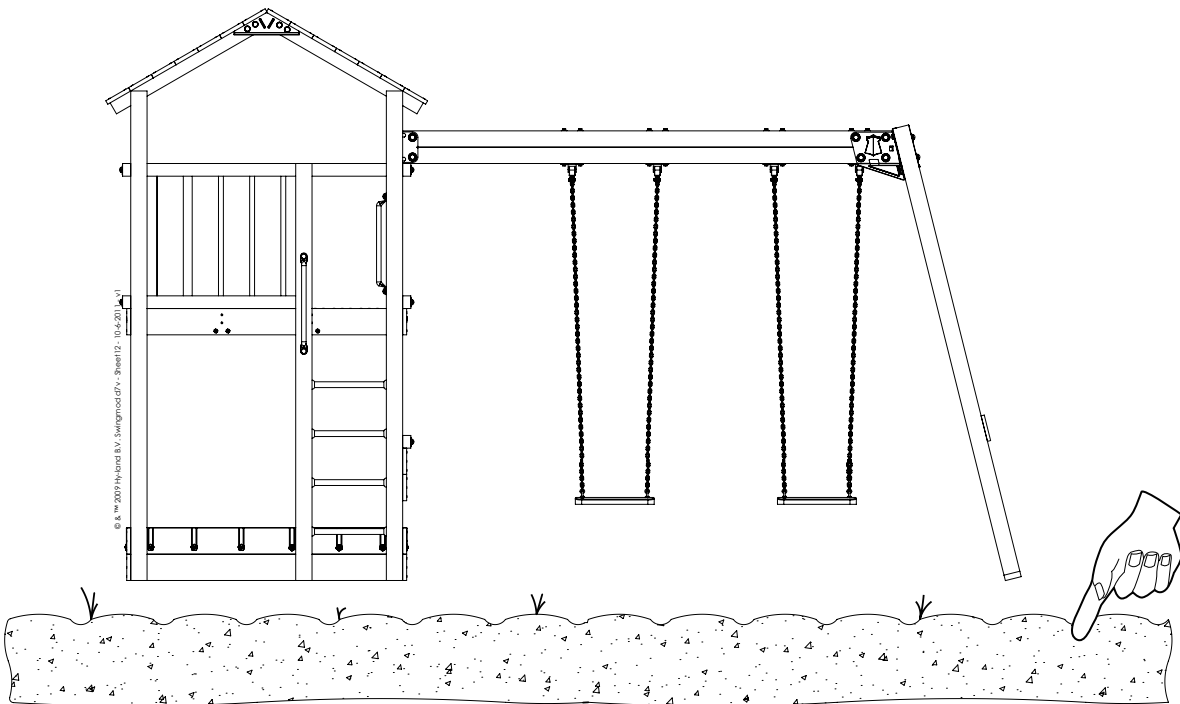

7.1k'

10\_032\_5013\_325\_01



2x

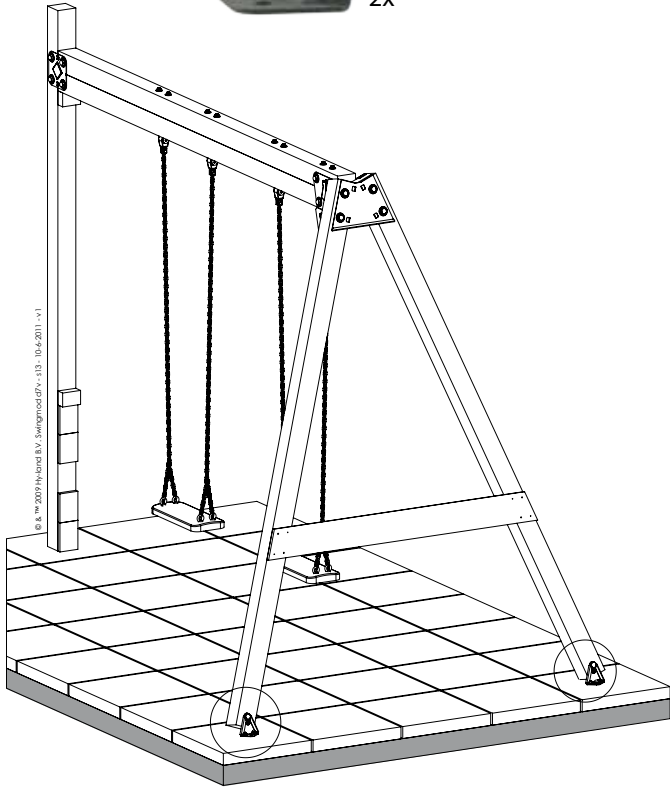

© & TM 2009 Hy-Land B.V. Swingmod (FV) - 113 - 10-4-2011 - v1

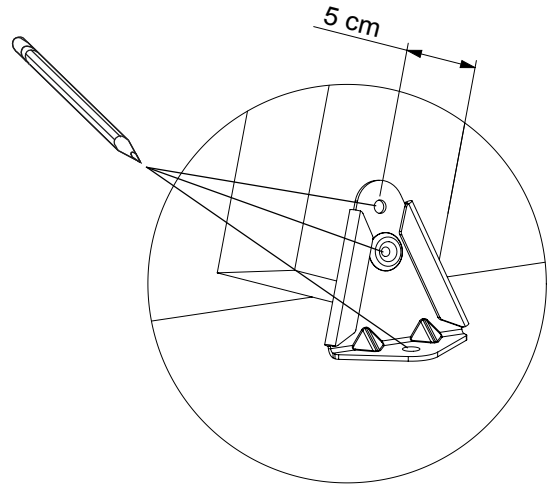

5 cm

7.1k''

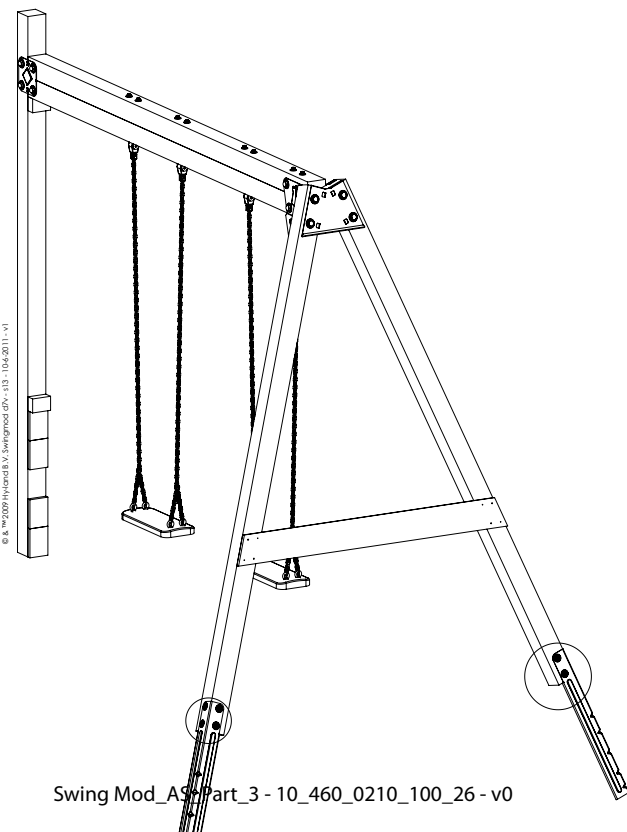

© & TM 2009 Hy-Land B.V. Swingmod (FV) - 113 - 10-4-2011 - v1

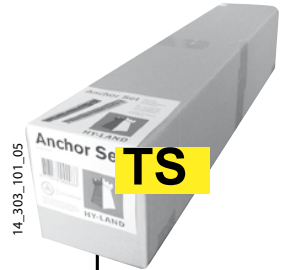

14\_303\_101\_05

Anchor Set TS

45mm



8x

2x

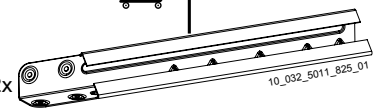

10\_032\_5011\_825\_01

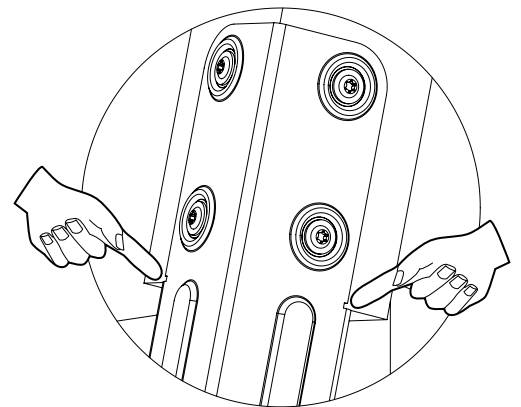

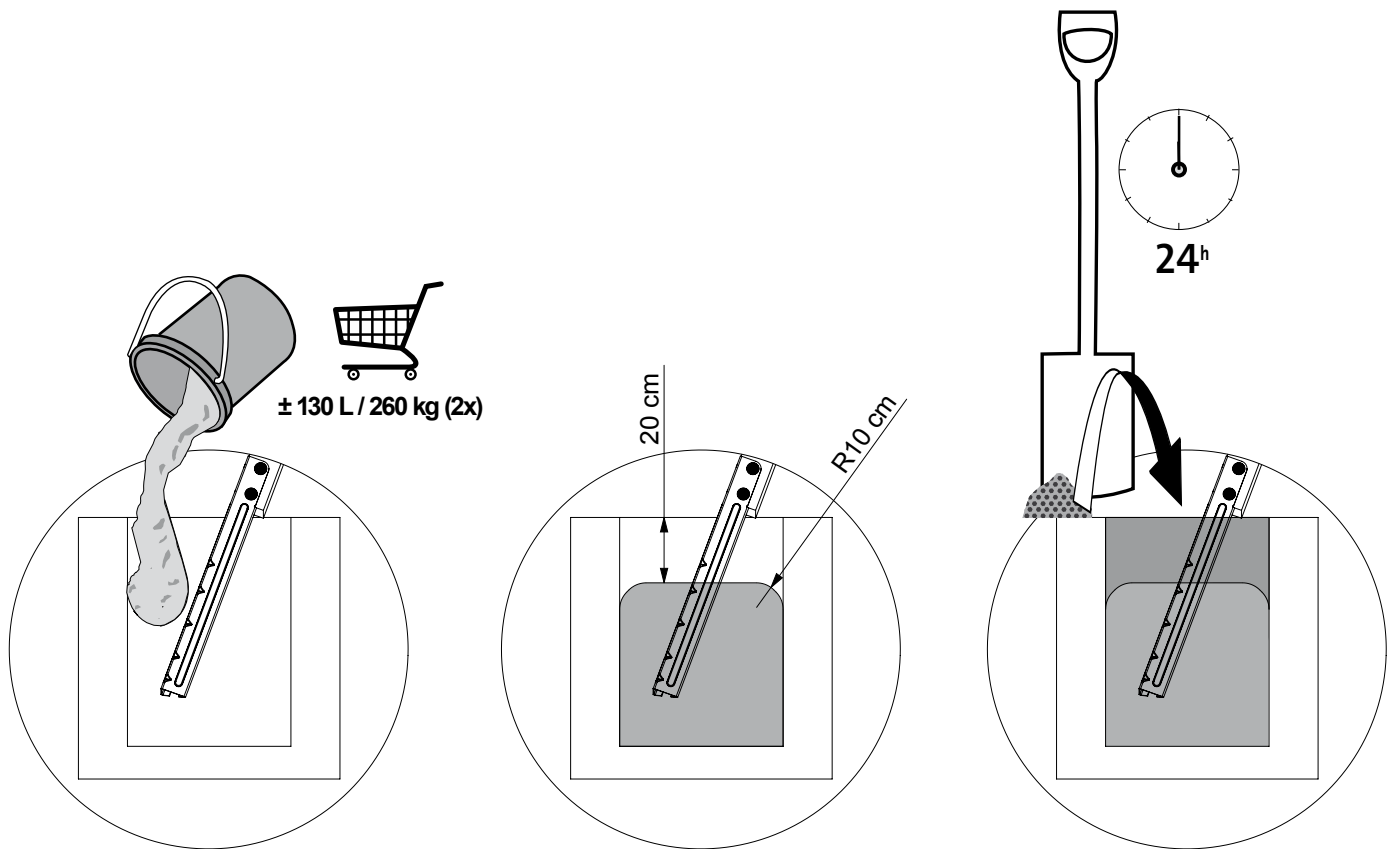
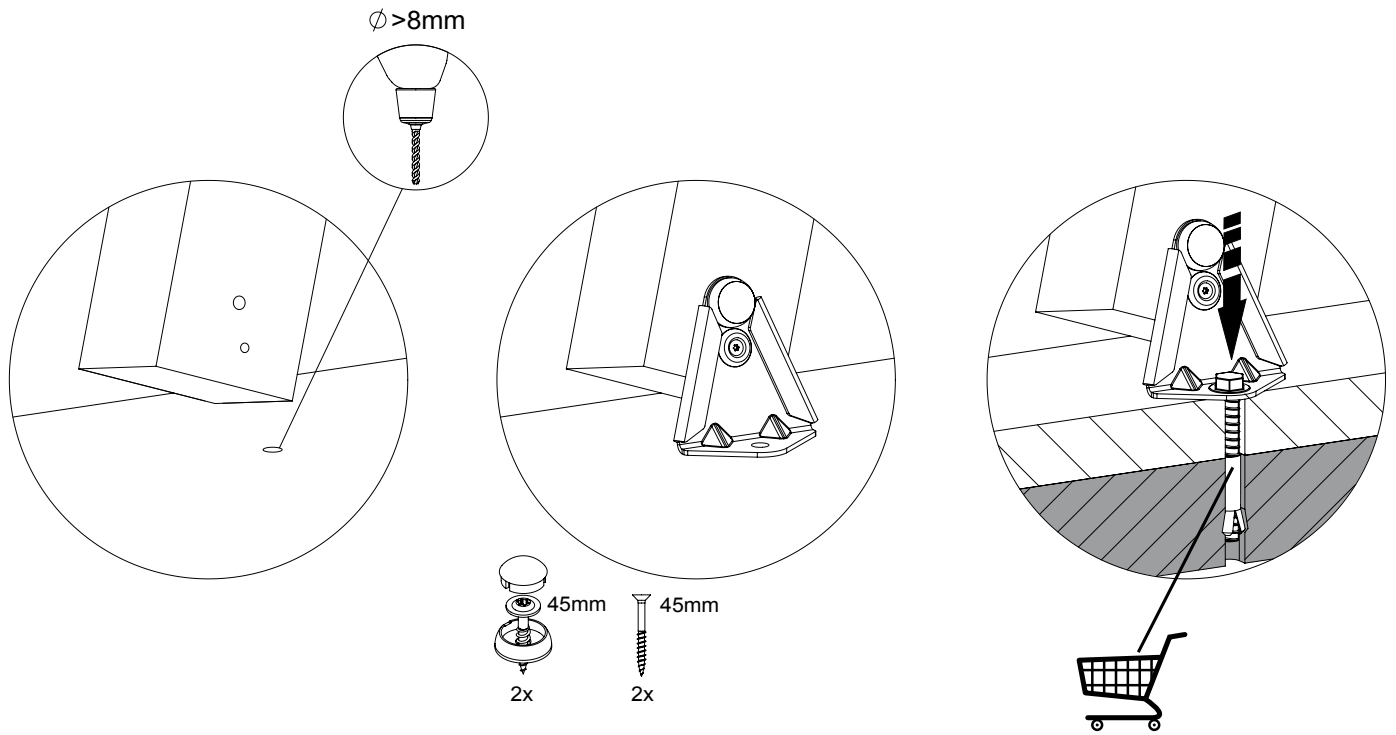

7.1l

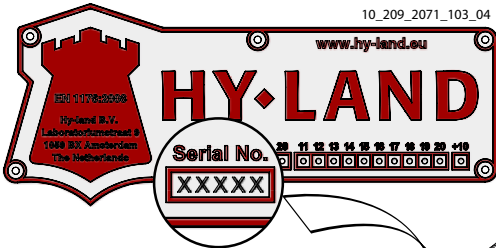

CODE?? 10\_XXX\_XXXX\_XXX\_01

Swing module  
0000001

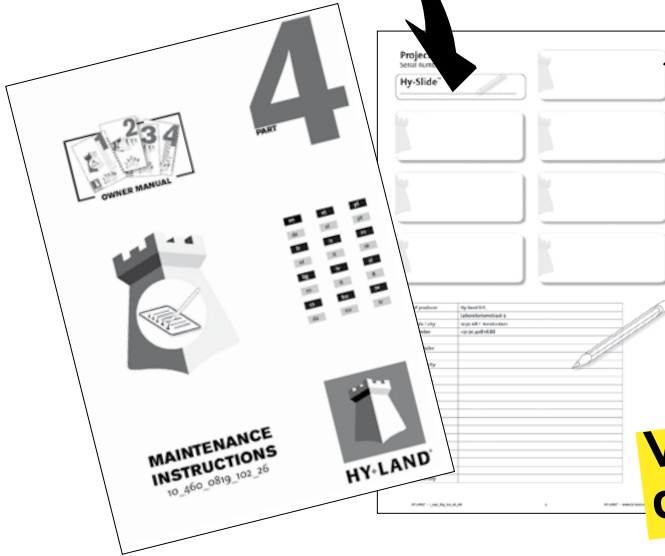

Vervang voor miniatuur  
deel 4 swing module

7.1m

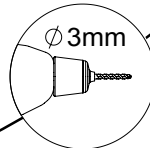
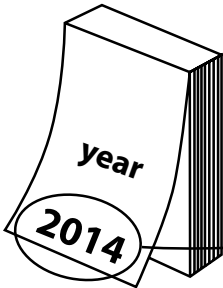
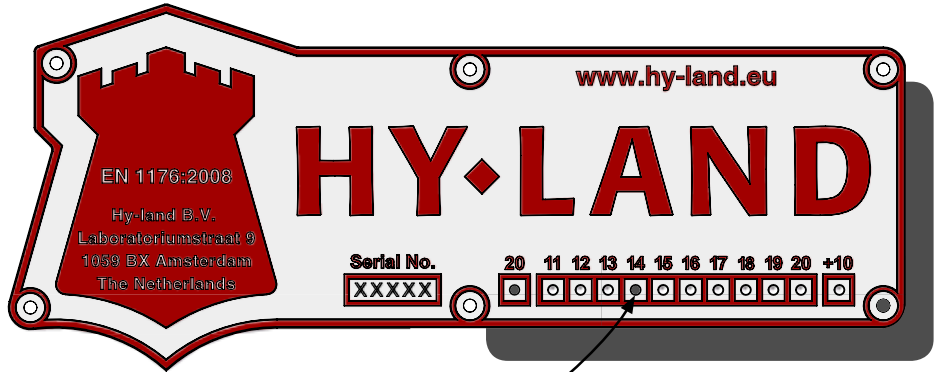

7.1n

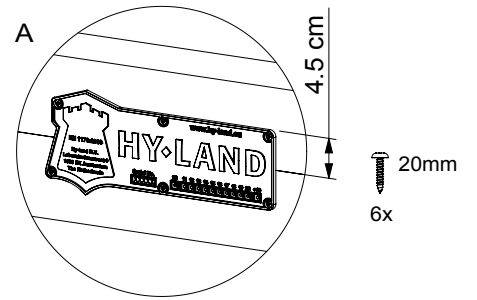
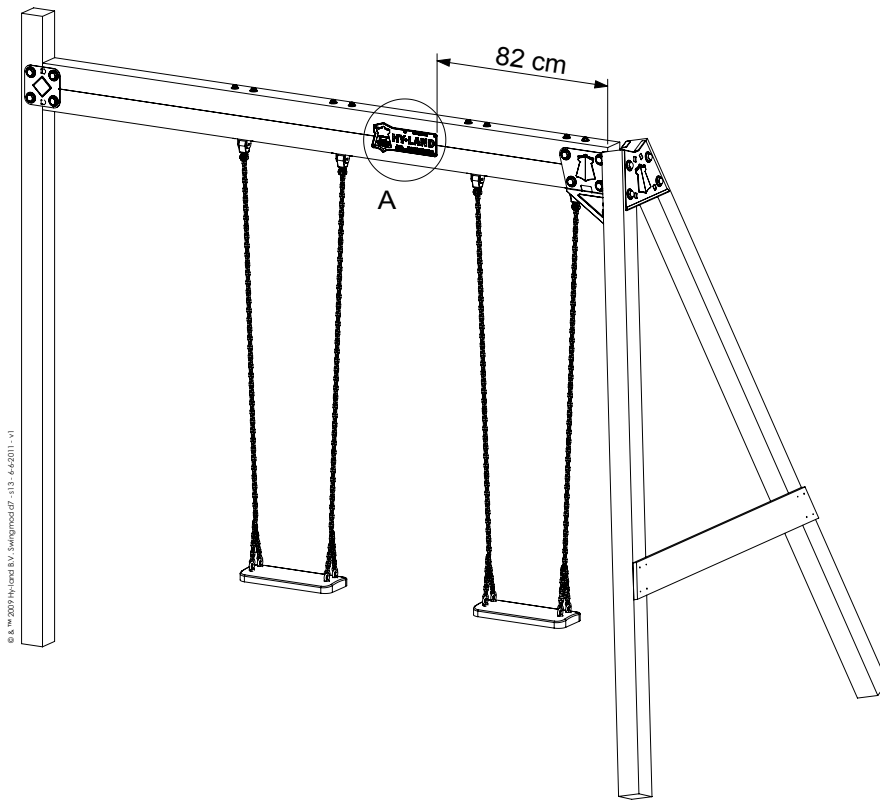

© 8. 2009 Hyland B.V. Swingmod 07 - 413 - 4-42011 - v1

# Example Project data

## Your Project data

Project no. :



Serial no. ID-plate

.....

Swing module  
000001

Serial no. Swing Module

.....

Name of manufacturer Hy-land B.V.  
Address Laboratorikumstraat 9  
Postal code / city 1059 BX / Amsterdam  
country The Netherlands  
Phone number +31 20 408 16 88  
url www.hy-land.eu  
email info@hy-land.eu

Name of owner \_\_\_\_\_  
Address \_\_\_\_\_  
Postal code / city \_\_\_\_\_  
country \_\_\_\_\_  
Date of delivery \_\_\_\_\_

Name of retailer \_\_\_\_\_  
Address \_\_\_\_\_  
Postal code / city \_\_\_\_\_  
country \_\_\_\_\_  
Phone number \_\_\_\_\_  
Date of delivery \_\_\_\_\_

Name of constructor \_\_\_\_\_  
Address \_\_\_\_\_  
Postal code / city \_\_\_\_\_  
country \_\_\_\_\_  
Phone number \_\_\_\_\_  
Date of assembly \_\_\_\_\_  
email \_\_\_\_\_



# Your Project data

Project no. :

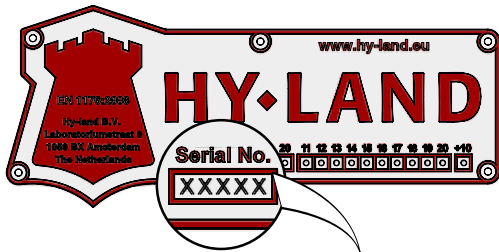
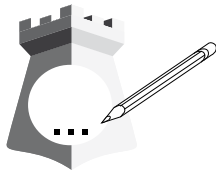

Serial no. ID-plate

Swing module  
0000001

Serial no. Swing Module

Name of manufacturer    Hy-land B.V.  
 Address                    Laboratoriumstraat 9  
 Postal code / city        1059 BX / Amsterdam  
 country                    The Netherlands  
 Phone number            +31 20 408 16 88  
 url                            www.hy-land.eu  
 email                        info@hy-land.eu

Name of owner            \_\_\_\_\_  
 Address                    \_\_\_\_\_  
 Postal code / city        \_\_\_\_\_  
 country                    \_\_\_\_\_  
 Date of delivery         \_\_\_\_\_

Name of retailer          \_\_\_\_\_  
 Address                    \_\_\_\_\_  
 Postal code / city        \_\_\_\_\_  
 country                    \_\_\_\_\_  
 Phone number            \_\_\_\_\_  
 Date of delivery         \_\_\_\_\_

Name of constructor      \_\_\_\_\_  
 Address                    \_\_\_\_\_  
 Postal code / city        \_\_\_\_\_  
 country                    \_\_\_\_\_  
 Phone number            \_\_\_\_\_  
 Date of assembly        \_\_\_\_\_  
 email                        \_\_\_\_\_



**Y-LAND**



aat 9  
sterdam

16 88  
and.eu  
nd.eu

merce :