

WALKING MACHINE W10

INSTRUCTION MANUAL

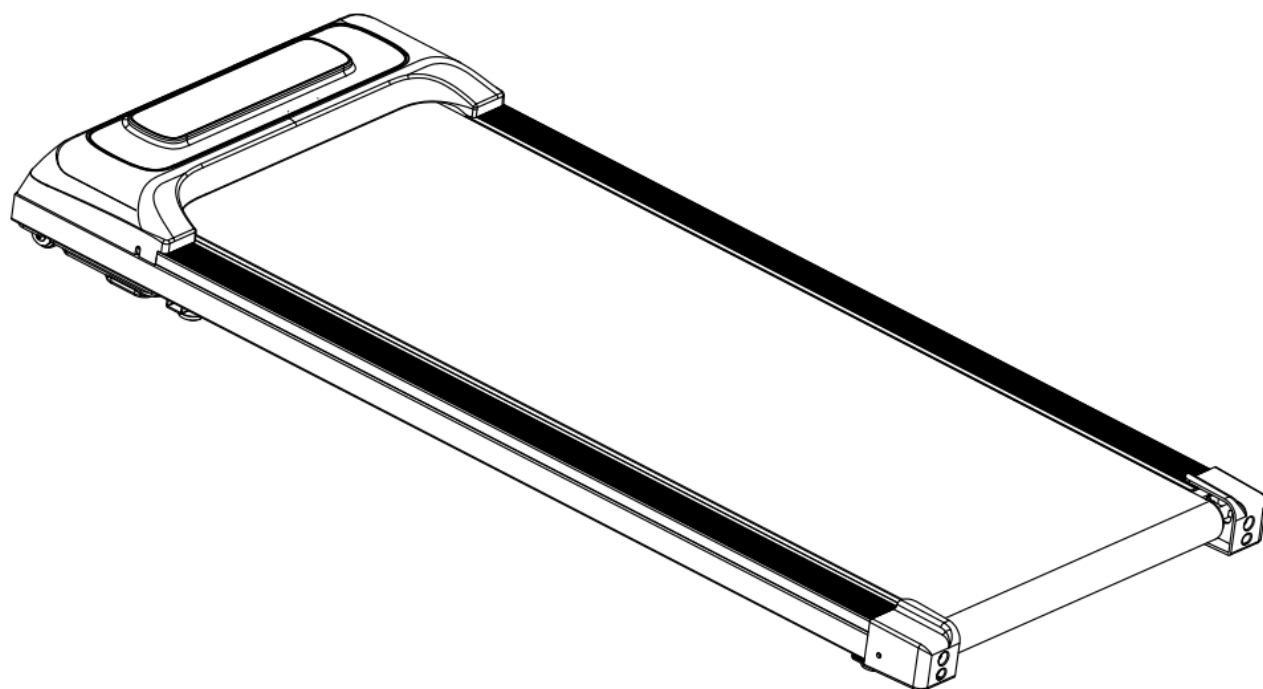

USER'S MANUAL

TABLE OF CONTENTS

1. FEATURES	P1
2. ASSEMBLY	P1-2
3. PRECAUTION	P3-4
4. CONSOLE PANEL	P5-6
5. OPERATION INSTRUCTION.....	P7-9
6. EXPLODED DRAWING&PARTS LIST.....	P10-11
7. Bluetooth App Manual.....	P12-16

1.FEATURES





Congratulations on choosing the motorized treadmill. You have taken the first step to a healthier and more rewarding lifestyle.

The treadmill is especially designed to meet your needs. The following are the features of the treadmill.

ITEM NO	A01 WALKING MACHINE
DISPLAY	3 LED display showing time, speed, distance, calories,step
RUNNING SIZE	40x100cm
SPEED	1-6 KM/H
REMOTE	Remote control, start/stop/speed+/speed-
BLUE TOOTH	Bluetooth app(Fitshow, Kinomap,Zwift)
MOVING WHEEL	2 moving wheels

2.ASSEMBLY

Hardware Packing List

Part Description	Quantity (PCS)
#29 Remote + Button cell 	1
#32 Allen wrench 	1
#30 Silicone Oil 	1
#17 Front Feet 	2
#31power cable 	1

Assemble the Feet

1. Stand up the treadmill with the top on the floor as shown below.
2. Install each foot in the positions as marked in the diagram.

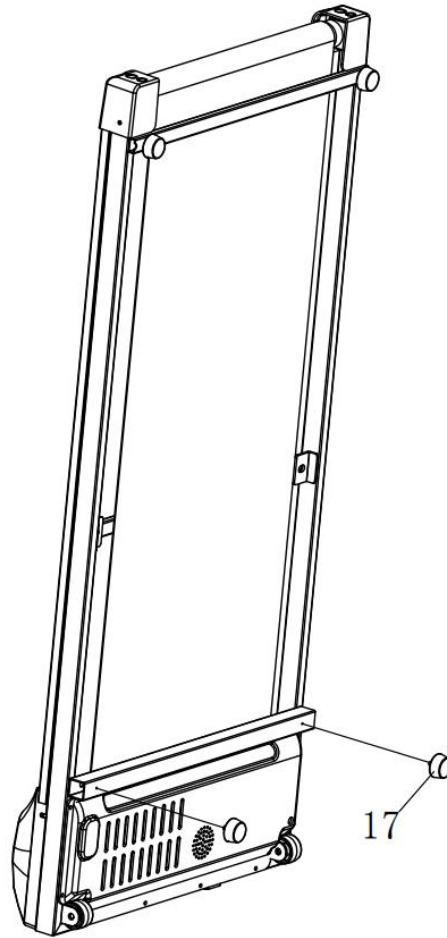

SET UP THE REMOTE

1. Remove the CR2032 battery from the bag.
2. Open the battery compartment cover using a small coin or your fingernail to twist it counterclockwise.
3. Place the battery into the battery compartment, under the clip. The positive side should face you.
4. Replace the battery compartment cover. Using the coin, twist it shut.

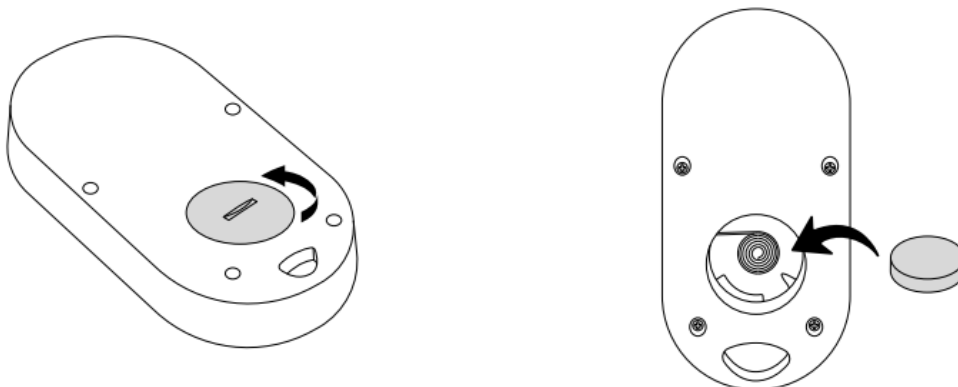

3. PRECAUTION

TO REDUCE THE RISK OF ELECTRIC SHOCK, BURN, FIRE OR OTHER INJURY, PLEASE READ THE FOLLOWING CAUTIONS AND INFORMATION BEFORE OPERATING THIS TREADMILL.

- It is the responsibility of the owner to be sure that all the users of this treadmill are informed of all warning and precautions.
- Keep pets and small children away from the treadmill at all times.
- Never start the treadmill while you are standing on the walking belt.
- The treadmill is capable of high speeds. To avoid sudden jumps in speed, adjust the speed in small increments.
- Regularly inspect and tighten all parts of the treadmill. Keep hands away from all moving parts.
- Never leave the treadmill unattended while it is running. Always remove the safety key and move the on/off switch to the "off" position when the treadmill is not in use. Refer to the console instructions page of this manual for the location and operation of the on /off switch.
- Never leave the treadmill unattended when plugged in.
- When folding or moving the treadmill, make sure that the safety lock is fully engaged. Do not remove the motor cover unless instructed to do so by an authorized service representative. Servicing other than the procedures in this manual should be performed only by an authorized service representative.
- Keep the plug and power cord away from heated surfaces.
- Keep all electrical components, such as the motor, power cord and on/off switch away from water or other liquids to prevent shock. Do not set anything on the handrails, computer console or belt.

FOR YOUR OWN SAFETY, BE ADVISED OF THE FOLLOWING:

- Assemble and operate the treadmill on a solid level surface. Keep at least four feet of clearance around the treadmill at all times.
- If the supply cord is damaged, it must be replaced by the manufacturer, its service agent or similarly qualified persons in order to avoid a hazard.
- Remove the remote and store it in a safe place when the treadmill is not in use. Keep this device out of reach of children for safety.
- Wear the proper exercise clothing and shoes for your workout. Do not wear loose clothing or shoes with leather soles or heels. Be sure to tie long hair back.
- Keep all loose clothing and towels away from the running surface. The belt will not stop immediately if an object gets caught in the rollers or belt. Should an object gets caught, turn the unit off immediately.
- Proceed with caution when getting on or off the treadmill. Use the handrails whenever possible. Step onto the running belt only when it is running at a very slow speed. Do not step off the treadmill while the belt is moving.
- To get on or off the running surface, straddle the running surface by standing on the right and left platforms on each side of the belt before starting the belt (to begin your workout) and after it has stopped (at the end of your workout).
- Never attempt to turn around while on the treadmill with the belt running. Keep your head and

body facing forward at all times.

- Never turn on the treadmill while someone is standing on the running surface.

- Do not rock the treadmill, stand on the handrails or computer console at any time.

- Do not overexert yourself during your workout. Stop your workout immediately if you feel overexerted. If you feel any pain or discomfort, please consult your physician.

- Do not attempt any service on the treadmill yourself other than the assembly and maintenance described in this manual. The treadmill is for household use only. Please refer to the customer service information contained in this manual should your treadmill require additional service other than that described in this manual.

- This appliance is not intended for use by persons (including children) with reduced physical, sensory or mental capabilities, or lack of experience and knowledge, unless they have been given supervision or instruction concerning use of the appliance by a person responsible for their safety. Children should be supervised to ensure that they do not play with the appliance.

ELECTRICAL SAFETY: This motorized treadmill must be grounded. Should it break or malfunction, grounding reduces the risk of shock. The treadmill is equipped with a power cord having an equipment-grounding conductor and a grounding plug. The plug must be inserted into an appropriate outlet that is properly installed and grounded in accordance with all local codes and ordinances.

IMPORTANT: Improper connection of the equipment-grounding conductor can result in a risk of an electric shock. If you are in doubt as to whether the treadmill is properly grounded, check with a qualified electrician or service person. Do not modify the plug provided with the treadmill. If it does not fit the outlet, then get a proper outlet installed by a qualified technician.

SURGE PROTECTION: Although this treadmill is equipped with built-in surge protection, an external surge protector is still recommended.

The treadmill will shut off automatically if it encounters a surge in power. A reset button is located at the lower front of the motor cover. If the treadmill should be shut down, turn the on/off switch to the "off" position, then press the reset button. The treadmill will now work properly.

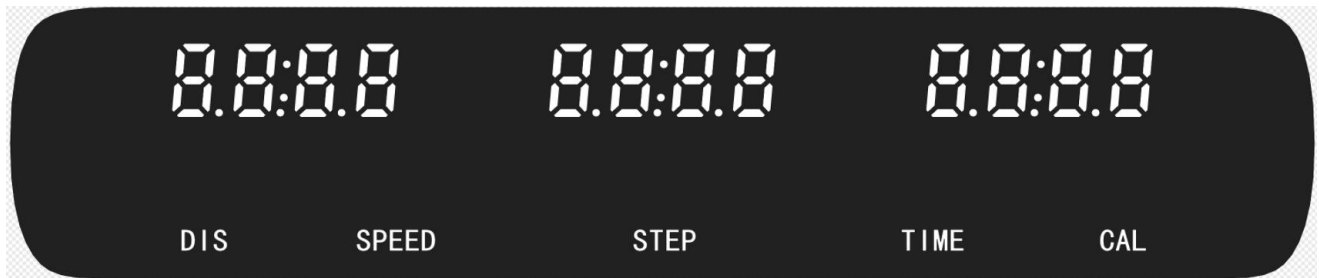

4 CONSOLE PANEL

1. CONSOLE PANEL

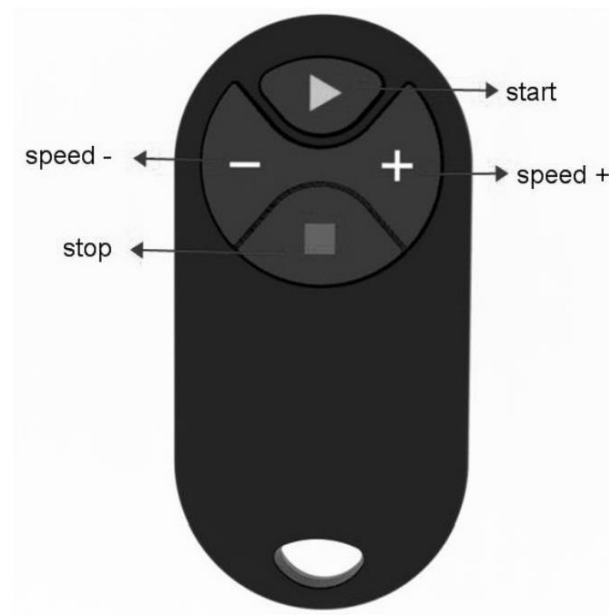

2. REMOTE CONTROL:



- 2.1,press  the triangle to start the treadmill. ,press  the square to stop the treadmill.
- 2.2 SPEED"+": speed + button, at the running state, press it will be add 0.1KM/H every time ,press it for a long time ,it will add the speed constantly;
- 2.3 SPEED"-": speed – button, at the running state, press it will decrease 0.1KM/H every time, press it for a long time, it will decrease the speed constantly.

3. DISPLAY

- 3.1 Speed window ; at the running state, it will show speed range: 1-6KM/H.
- 3.2 Calories window ; at the running state, it will show calories:0—999CAL.
- 3.3 Time window ; at the running state, it will show running time:0-99 minutes.
- 3.4 distance window ; at the running state, it will show running distance:0-99.9 KM.
- 3.4 step window ; at the running state, it will show step number:0-9999 steps.

4. ERROR SIGNAL

Please check the error Signal display of the window

Code	Problem	Possible Reason	Solution
E01	Display did not receive the signal	Cable connection	Check or replace the Cables
		display default	replace the display
		controller default	replace the controller
E02	The problem between controller and motor	motor connect wires did not connect well	Check that the motor wires are connected correctly
		No voltage output or abnormal voltage output of controller board	replace the controller
		motor default	replace the motor
E03	The speed is abnormal	The photoelectric sensor is not properly assembled on the motor	reassemble the sensor
		Poor photoelectric sensor	replace the sensor
		Failure of controller board	replace the controller
E04	over voltage	Input voltage too high	adjust the voltage
		motor default	replace the motor
		Failure of controller board	replace the controller
E05	over power current	power current too high	adjust the power current
		Problems with the assembly structure of the treadmill and the motor cause motor resistance or blockage	check the structure if it is well
		controller default	replace the controller
E06	over voltage	Input voltage too low	Please check whether the power supply line is normal
		Failure of controller board	replace the controller

5. OPERATION INSTRUCTION

1. PREPARATION BEFORE START

- 1.1 Plug in the power cord . If the machine is not operated or moved for a long time, please turn off the power.
- 1.2 Always take the remote control on your hand to start or stop the treadmill.

2. START

- 2.1 Press the triangle button  to start the machine at a speed of 1 KM/h.
- 2.2 Press “+” “-” button can control the speed, with one press 0.1 KM/h will be increased or decreased. Press the key without stop can get to the speed you want. The highest speed is 6KM/h while the lowest is 1KM/h.

3. WAY TO STOP THE MACHINE

- 3.1 Press the square button  ,the machine will stop working.

IMPORTANT SAFETY INSTRUCTION

1. The machine is for home use.
2. The voltage for the machine is 220V.
3. Before operating the machine, please do 10-minute warm-up and wear clothes and shoes that are suitable for sports.
4. Do not stand on the motorized treadmill when you adjust, test or start the motorized treadmill.
5. Be careful when you get on or off the machine. Before starting the machine, please place your feet on the side rails (not the running belt). After starting the machine, stand on the belt with the machine operating at the lowest speed. Then increase the speed gradually. Before getting off the machine, please decrease the speed to the lowest level in case of any danger.
6. When operating, press the safety at any time, the motor will stop working and the controller will give warnings.
7. Children should be supervised by adults when they play on or beside the machine.
8. The motorized treadmill should be protected from sunshine, damp and dirt. All the parts shall be cleaned often.
9. When the machine is free from using for a long time, please don't place any objects or stand on the machine.

MAINTENANCE

In order to prolong using time of the motorized treadmill, regular maintenance is necessary.

1. When the machine is operated for the first time or for a long time, some lubricant on the running deck or the back of the running belt is necessary in order to lessen the burden of the motor.
2. Clean the parts of the machine regularly to prevent dirt from disturbing the operation of the parts.
3. Drop some lubricant on the axletree of the roller regularly to keep the axletree in good condition.
4. Check the screws and bolts regularly. If they are loose, please screw them down.

LUBRICATION

The treadmills have already been spread with "Silicone Oil" in advance before leaving the manufacturing plant. Silicone oil is without volatility and has gradually permeated through the running belt. There will be no need to re-spread the oil in normal circumstances.

To maintain the running belt, we have included a small bottle of "Silicone Oil". "Silicone Oil" may be re-spread once the resistance has been increased and the running belt starts rubbing against the running deck. To hold open the running belt from two sides, apply the silicone oil with an even motion on the center of the running deck. Allow the silicone oil to 'set' for one minute before using the treadmill.

Attention: Only use "Silicone Oil" lubricants for this equipment. **In addition, do not add any other oil ingredient; otherwise the treadmill will be damaged. Do not over-lubricate the walking board. Excess lubricant should be wiped off with a clean towel.**

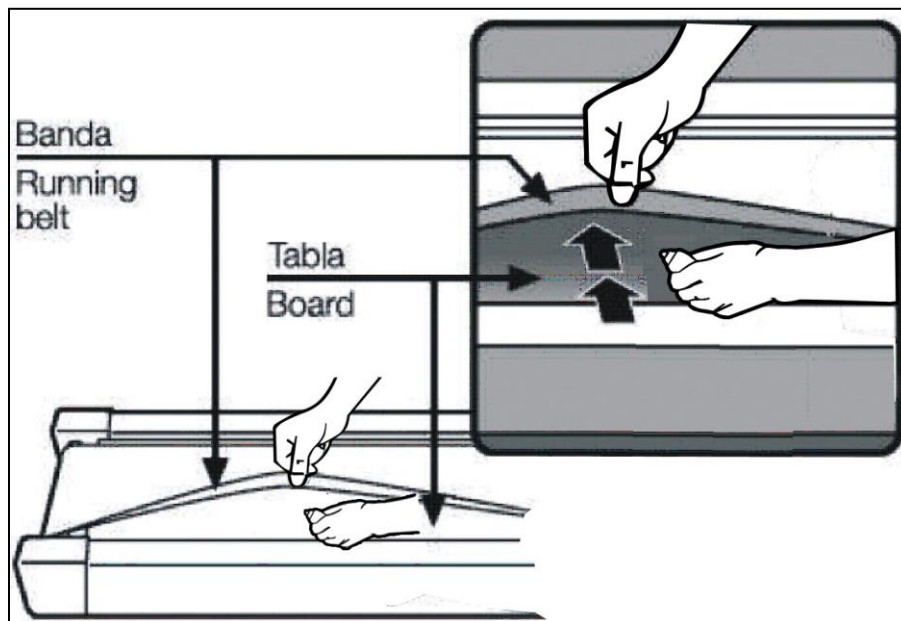

RUNNING BELT ADJUSTMENT

1. If the belt has drifted to the right (see figure A):

- Turn off the treadmill and unplug the treadmill.
- Using the Allen wrench, turn the right adjusting belt $\frac{1}{4}$ of a turn clockwise.
- Plug the treadmill back in and turn it on. Observe the treadmill running for deviations.
- Repeat the steps above until the running belt is centered and running centered down the platform.

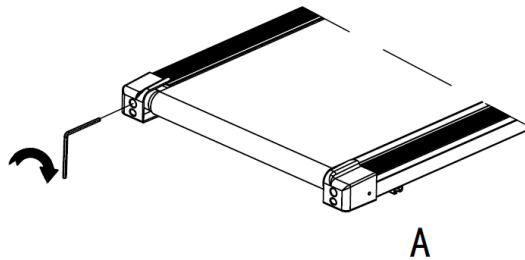

2. If the running belt has drifted to the left (see figure B):

- Turn off the treadmill and unplug it.
- Using the Allen wrench, turn the right adjusting belt $\frac{1}{4}$ of a turn counterclockwise.
- Plug the treadmill back in and turn it on. Observe the treadmill running for deviations.
- Repeat the steps above until the running belt is centered and running centered down the platform.

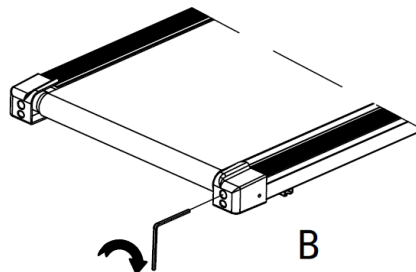

3. Overtime, the running belt will gradually become slack. The belt can be tightened using the following instructions (see figure C):

- Turn off and unplug the treadmill.
- Using the Allen wrench turn each adjusting bolts clockwise $\frac{1}{4}$ of a turn.
- Power on the treadmill, then stand on the belt to confirm the tightness of the belt.
- Repeat the previous steps until the belt is at moderate tightness.

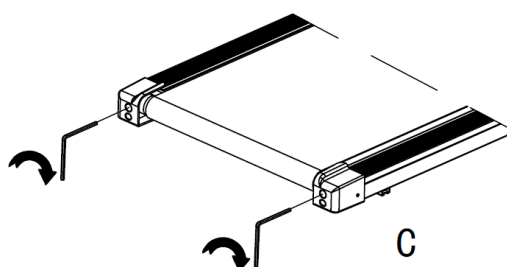

6. EXPLODED DRAWING

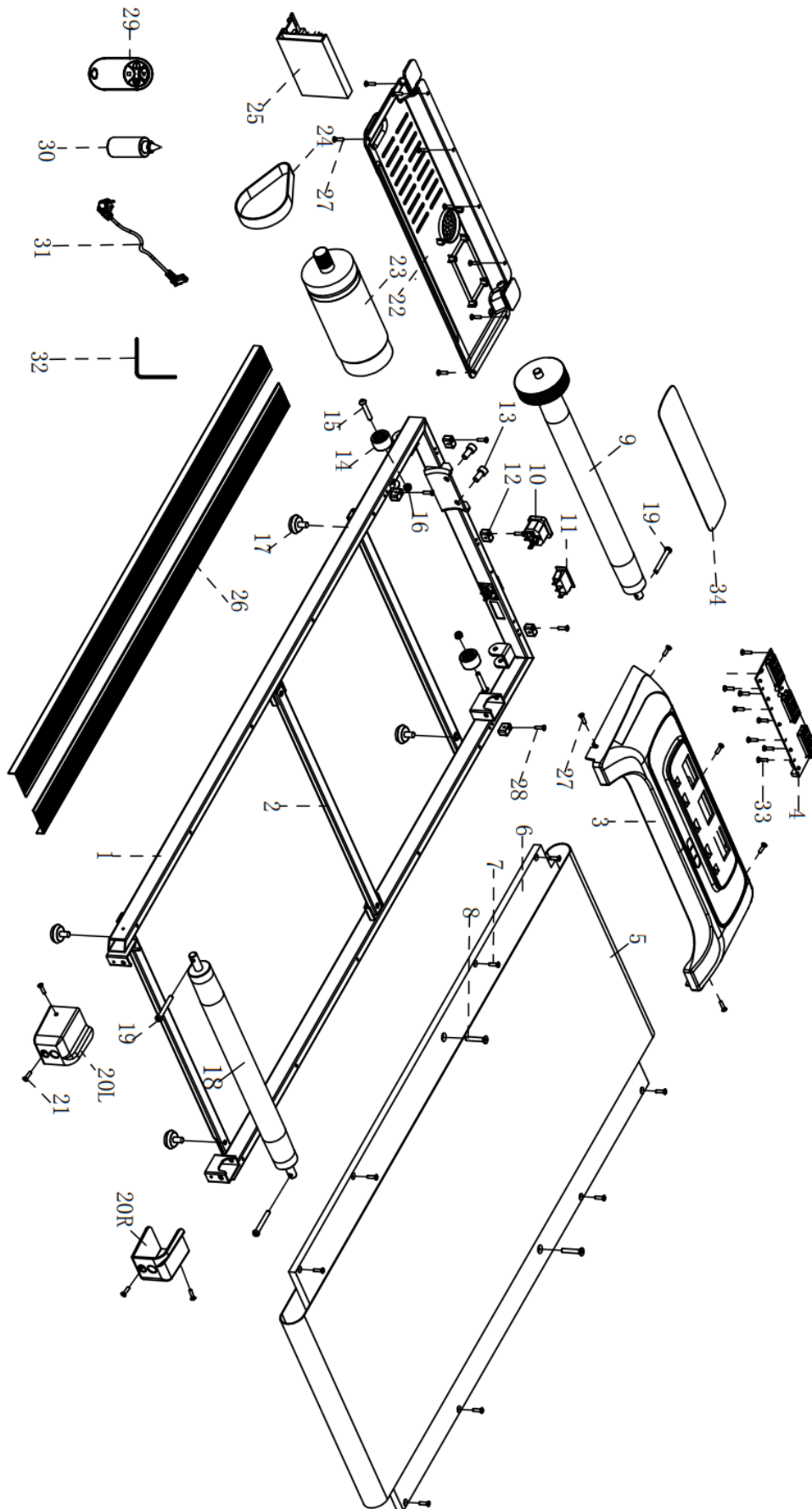

PARTS LIST

NO	parts name	qty	No	parts name	qty
1	deck frame	1	18	real roller	1
2	support bar	1	19	bolt M6x50	3
3	motor cover	1	20	end cap(L/R)	2
4	display	1	21	screw M4.2x13	4
5	running belt	1	22	lower cover	1
6	running deck	1	23	motor	1
7	blot M4x20	8	24	motor belt	1
8	bolt M8x35	2	25	Controller board	1
9	front roller	1	26	side rail	2
10	power plug	1	27	screw M4X16	13
11	switch	1	28	screw M4x20	5
12	motor cover fixer	5	29	remote	1
13	bolt M8x10	2	30	silicon oil	1
14	front wheel	2	31	power cable	1
15	bolt M8x40	2	32	Allen wrench	1
16	nut M8	2	33	screw M3X7	8
17	feet	4	34	overlay	1

Fitshow User Manual

1. FitShow Download



Scan QR code to download the APP directly, or download and install over the application stores by search 'FitShow'.

2. Application Operation

2.1 User register/signup and login

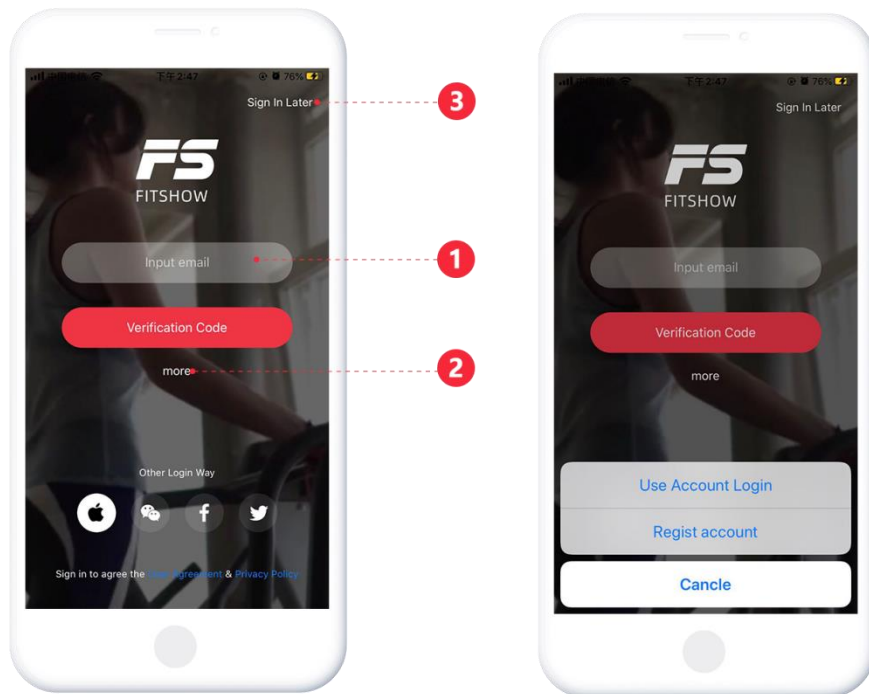

【1】 : Generate a verification code to log in directly

【2】 : Tap 'More' -> Password Login to input the existing account and password

【3】 : Log in as a guest

2.2 Device Connection

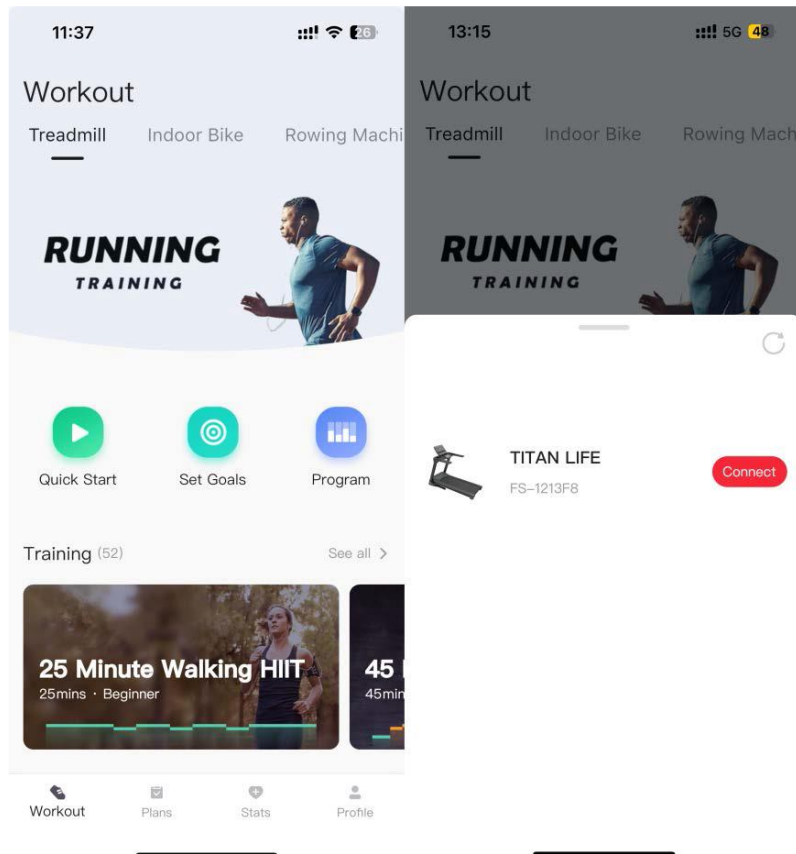

Before connecting the device, please make sure the system Bluetooth and GPS(Android8.0 and above required) are ON status. Then go to [workout] page, get the devices nearby via Bluetooth search.

Note:

1. Please do not bind devices by the phone Bluetooth list which will disable the APP. This mean need open the Fitshow APP, then click the workout page, select one of the trainer machine "treadmill, indoor bike, rowing machine...." ,click "QUICK START" "Set Goals" or "Program" , searching device to find "TITAN LIFE" and connect.

3. The Third-Party Application

3.1 Kinomap

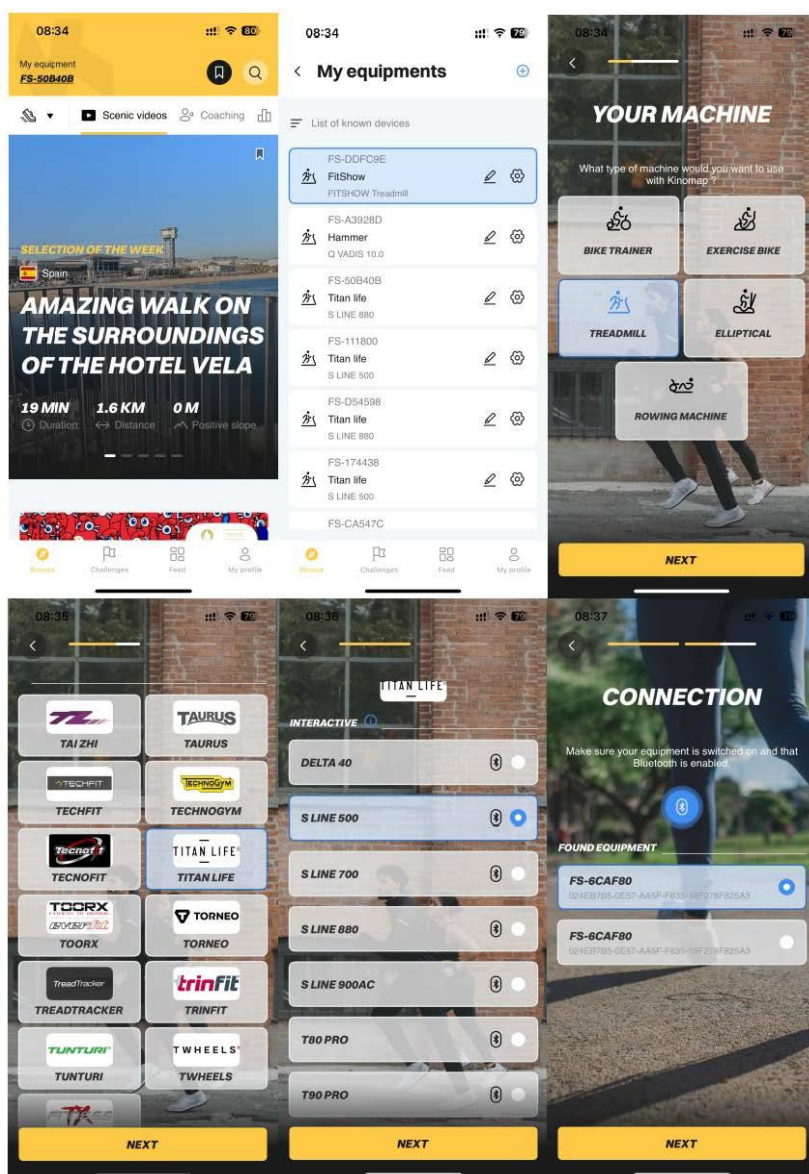

Search, download, and install Kinomap over the App Store.

- [1]** Enter Kinomap to Click [My Equipment] page;
- [2]** Select to add more fitness equipment, click  ;
- [3]** Select the desired device type, click "NEXT" ;
- [4]** Tap "TITAN LIFE" entrance, click "NEXT"
- [5]** Tap the matching devices like "TITAN LIFE W10" , click "NEXT" ; Find related Bluetooth and click "NEXT" , new device added successfully.
- [6]** Find related videos to start sports.

3.2 ZWIFT

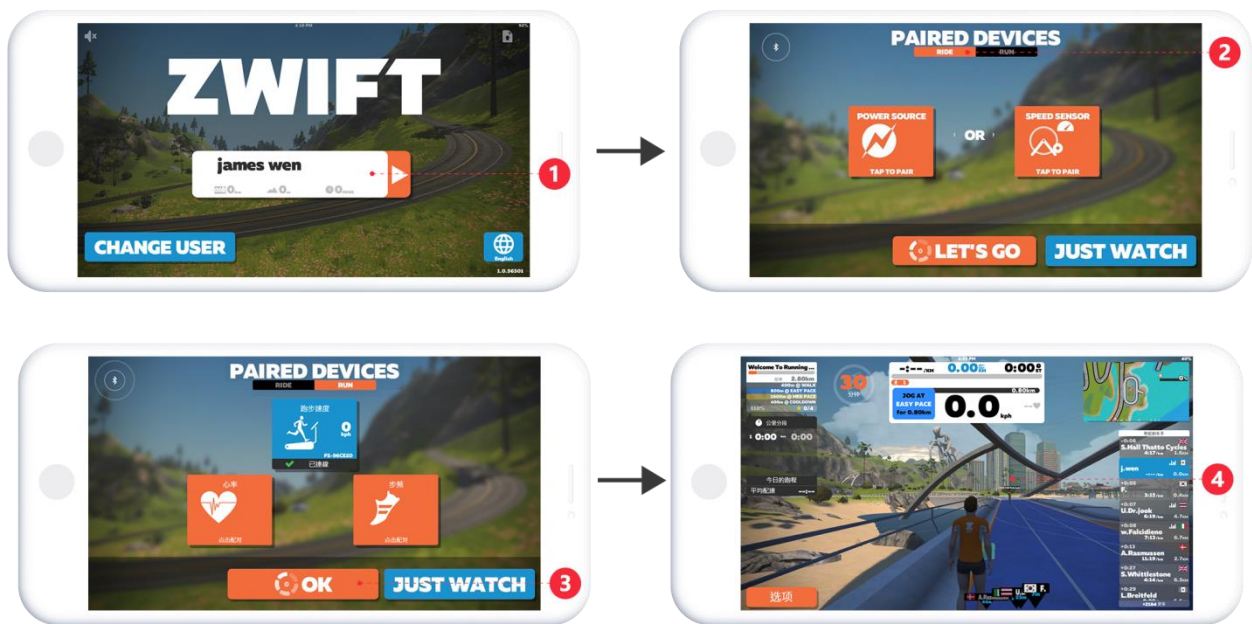

Search, download, and install ZWIFT over the App Store.

- 【1】** Enter ZWIFT to register an account;
- 【2】** Login account to select the paired riding or running equipment;
- 【3】** Pair device successfully, tap OK to start sport;
- 【4】** For riding equipment, start riding directly. For running equipment, need to press the start button to start running.