

Assembly Instruction

Trampoline 366/426

144"(12FT)/ dia. 366cm x H.273cm

168"(14FT)/ dia. 426cm x H.273cm

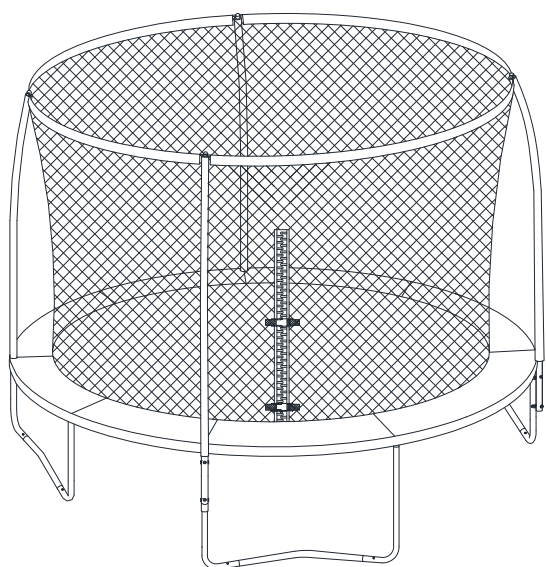

366cm

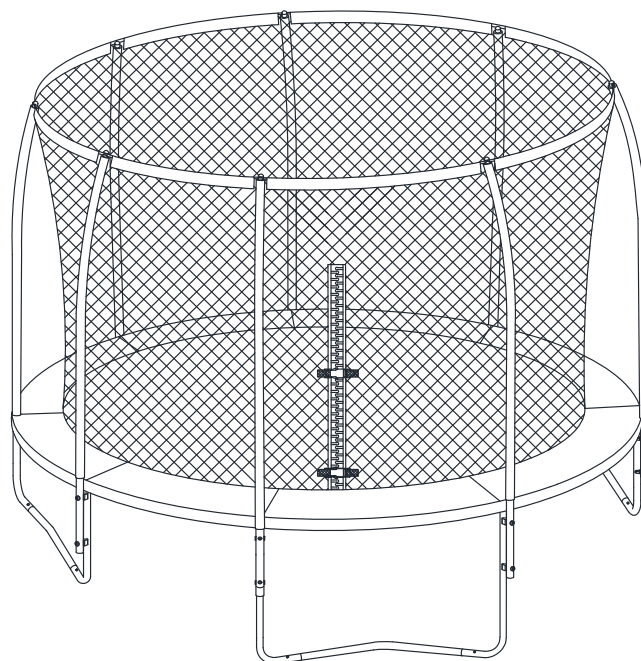

426cm

It is very important that you read and understand the instructions before assembling and using the trampoline.

We hope that you will enjoy using the trampoline. A trampoline is great fun and at the same time good exercise. It takes some time to assemble so please read all the instructions before starting and it will be easier. It is possible that the assembly will take more than an hour, so be patient and get the assistance of a friend.

IMPORTANT

Read the following statements and warnings to avoid serious or fatal injury.

Warning!

- Max 100 kg.
- Only for domestic use.
- Outdoor use.
- Only one user. Collision hazard.
- The net should be replaced every year.
- Adult supervision required.
- Do not perform somersaults (flips). This is very dangerous and you risk serious injury or death.
- Always close the safety net opening before jumping.
- Read the instructions.
- The trampoline shall be assembled by an adult in accordance with the assembly instructions and then checked before the first use.
- Jump with proper gym shoes or barefoot only.
- Empty pockets and hands before jumping.
- Always jump in the middle of the mat.
- Do not use when the mat is wet.
- Do not eat while jumping.
- Do not exit by a jump.
- Limit the time of continuous usage (take regular breaks).
- Do not use in strong wind conditions and secure the trampoline.
- Do not try to jump over the net.
- Do not purposely jump onto the net.
- Do not try to purposely rebound off the safety net.
- Do not hang on the top of the net, or try to climb the netting.
- Take off any jewellery that could become entangled with the netting or cut the netting.

Placement of the trampoline

Do not place the trampoline on a concrete floor or other hard surfaces. The ideal placement is a level, stable surface like a lawn. There must be at least 2 meters of space around the trampoline. Check that there are no wires, tree branches, fences or other possible hazards above and around the trampoline. The trampoline should not be placed near any pools, swings, slides, climbing frames or other obstructive installations. The trampoline is not intended to be buried into the ground.

Weather conditions

The trampoline should not be used when wet. In winter conditions, please disassemble the trampoline and store all fabric parts (mat, foam pad, safety net) inside. In strong wind conditions, disassemble the foam pad and safety net and secure the trampoline to the ground using Ground Stakes/Anchors (sold separately).

How to use

Take it easy at first. Don't try difficult moves.

Do not jump when tired - this increases the risk of injury. Be sure to wear proper shoes, e.g. gym shoes, or be barefoot when jumping.

Never step on the frame pad. It is not constructed to support the weight of a person. Never dismount by jumping off the trampoline. Always climb off. Don't use the trampoline under the influence of drugs or alcohol.

Always have someone else watching while you jump. If you should injure yourself you will have someone to assist you.

Always start your jump at the centre of the mat. If you land more than 30 cm away from the edge of the logo, stop your jump immediately!















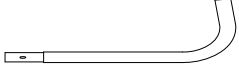

Restart your jump at the centre of the mat.

Assembly









Please read the assembly instructions fully before starting to assemble the trampoline. It is advisable to have two people assembling it together.

Start first by checking that you have all the required parts. The reference No. of each part will be used in the instructions to guide you.

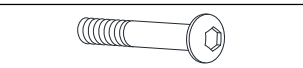
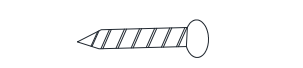
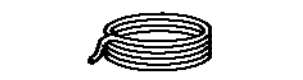
Trampoline Parts List

Part Number	Diagram	Description	366cm Quantity	426cm Quantity
1		Trampoline Mat	1	1
2		Frame Pad	1	1
3		Top Rail with Leg Sockets	8	8
4		Leg Base	4	4
5		Reinforce Steel	4	8
6A		Right L-Shaped Leg - (2 holes)	4	0
6A		Right L-Shaped Leg - (3 holes)	0	4
6B		Left L-Shaped Leg - (3 holes)	4	4
7		Galvanized Springs	72	88
8		Long Bolt (50mm)	4	0
9		Screws (15mm)	8	8
10		Cap Nut	12	16
11		Larger Spring Washer	20	24
12		Arc Washer	20	24
13		Wrench	1	1
14		Spring Loading Tool	1	1
15		Allen Wrench	1	1

Enclosure Parts List

Part Number	Diagram	Description	366cm Quantity	426cm Quantity
A		Upper Frame Tube with Foam	4	8
B		Lower Frame Tube with Foam	4	8
C		Cable Wire	12	12
D		Long Bolt (79mm)	8	16
E		Self-Locking Screw	8	16
F		Cord	7	8
G		Enclosure Netting	1	1
I		Small Spring Washer	4	8
J		Plastic Cap	4	8
K		Cap	4	8
L		Gap Spacer	8	16
M		End Cap	4	8



REMEMBER TO USE GLOVES DURING ASSEMBLY TO AVOID PINCHING AND IT WILL TAKE AT LEAST TWO PEOPLE TO ASSEMBLE THE TRAMPOLINE

Trampoline assembly

STEP 1

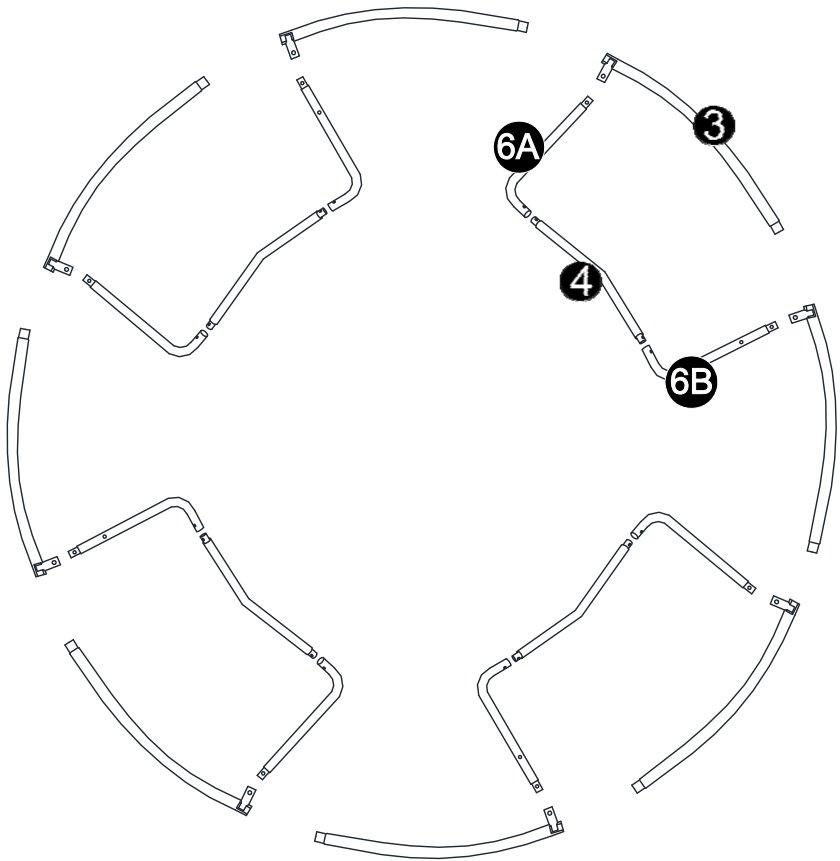

366

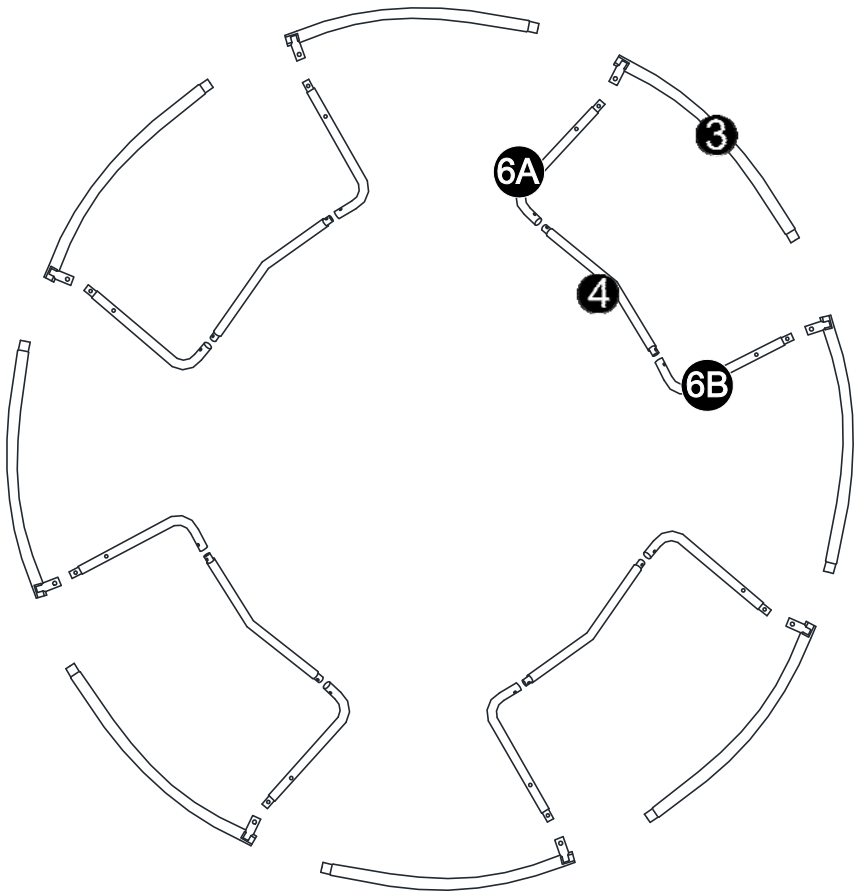

426

STEP 2

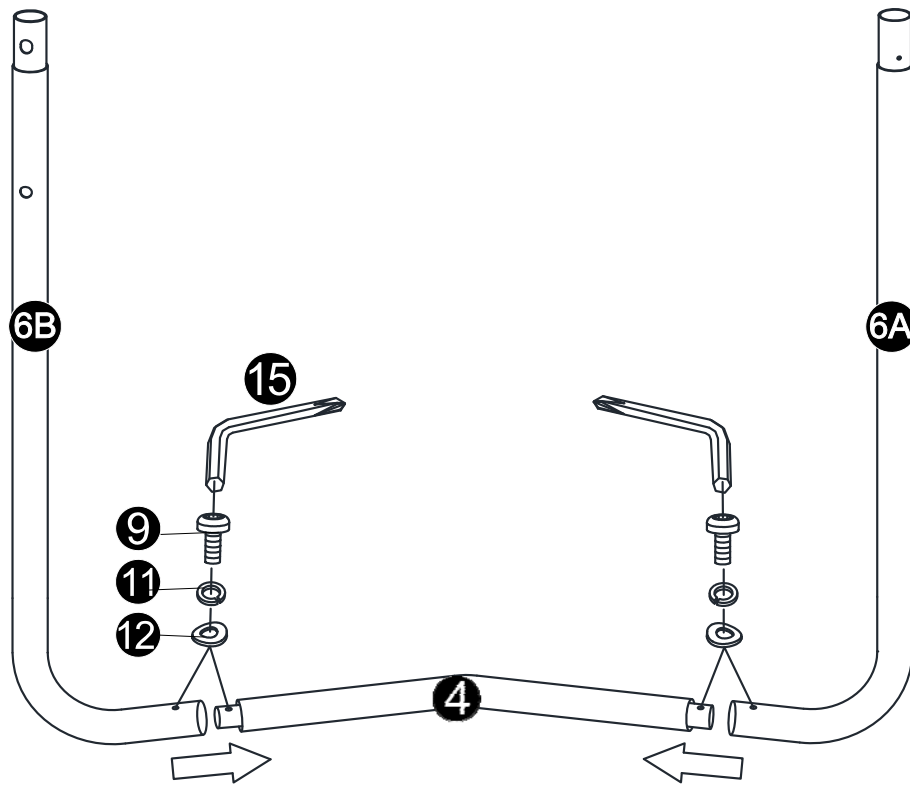

366

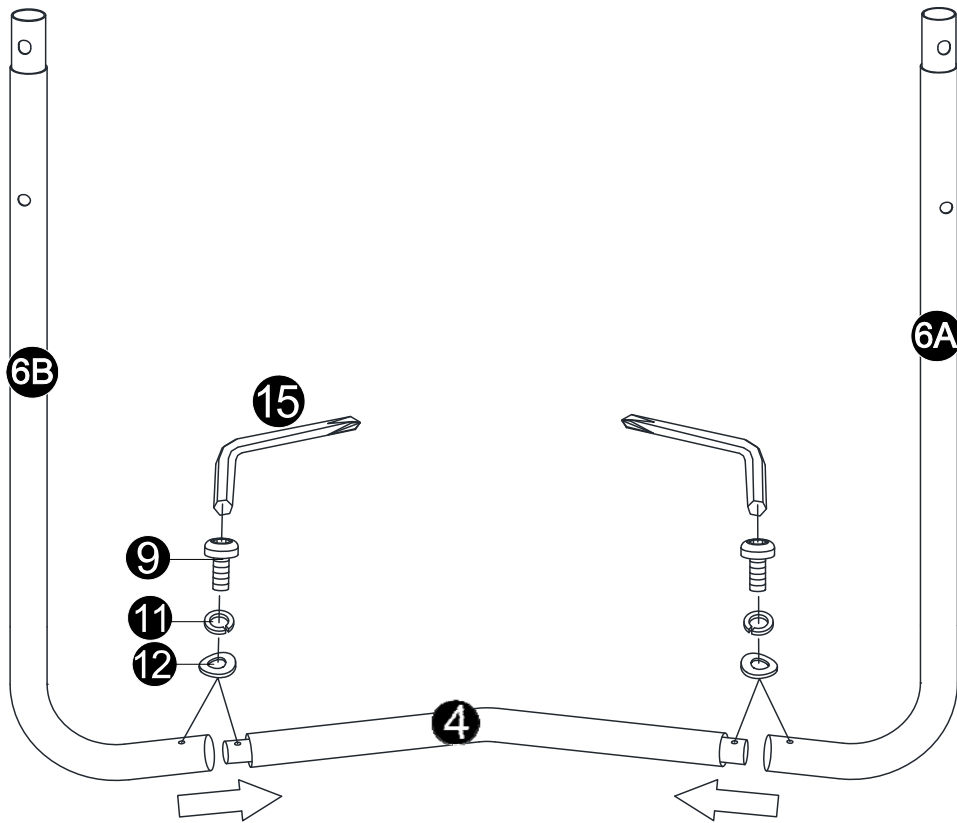

426

STEP 3

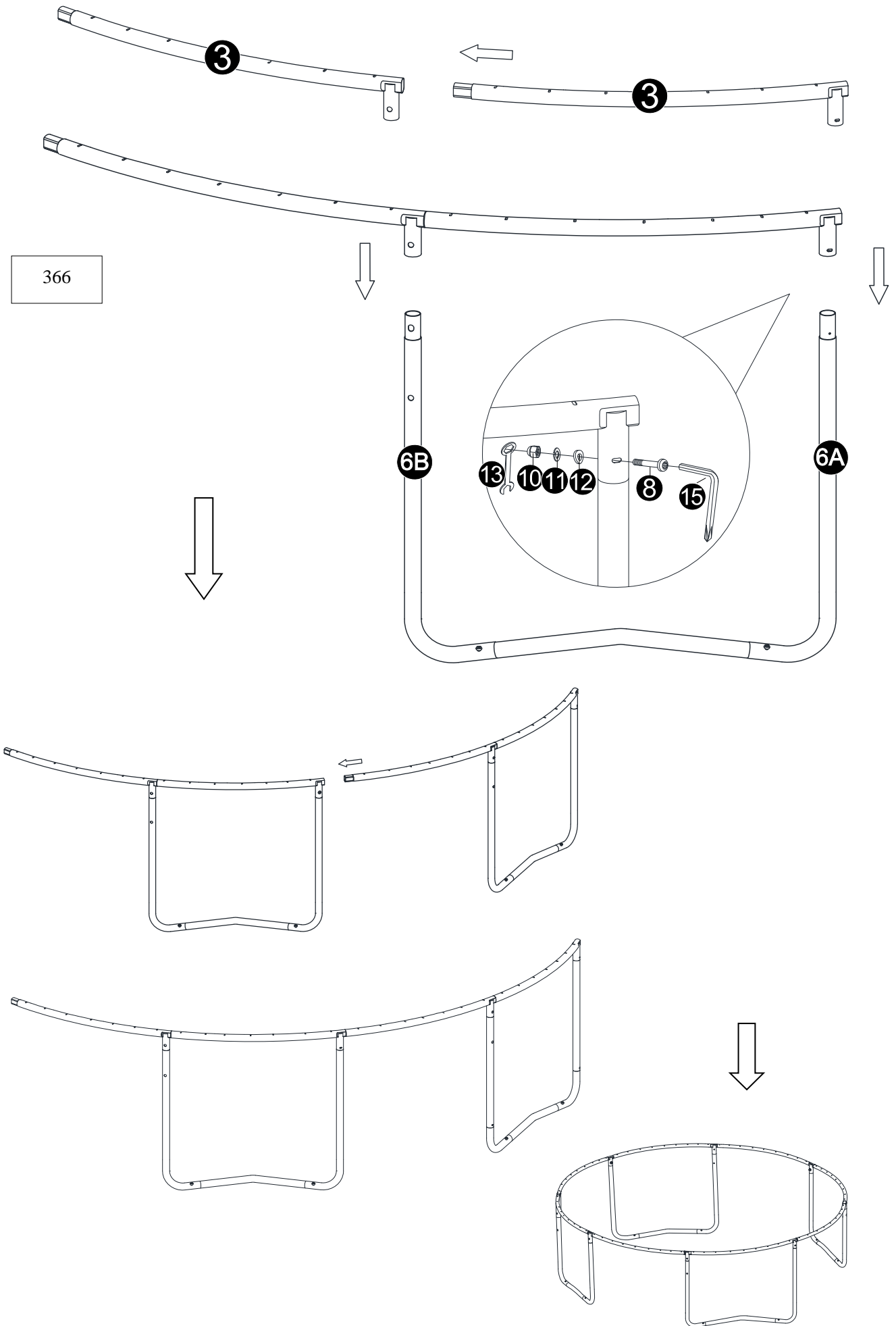

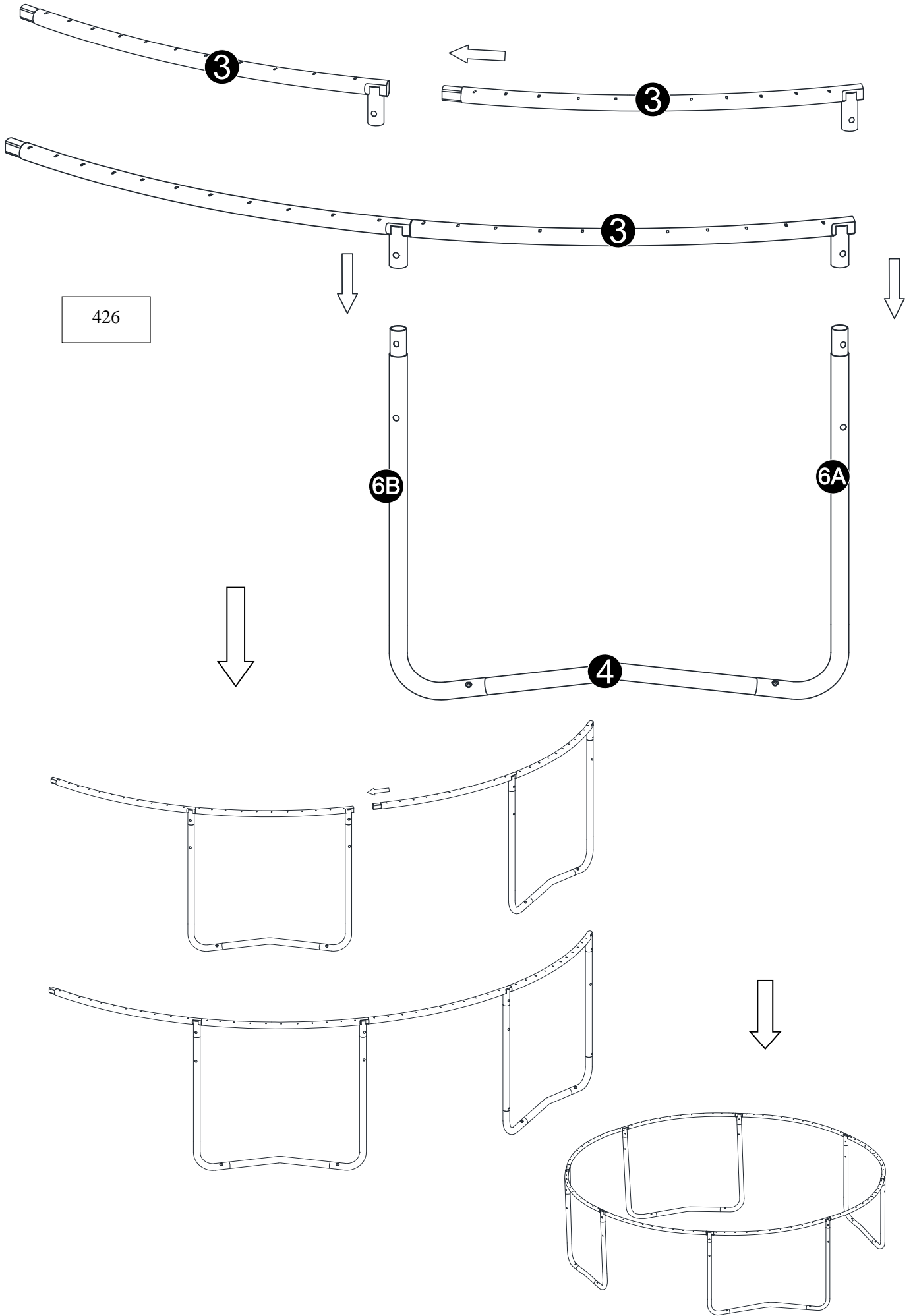

STEP 4

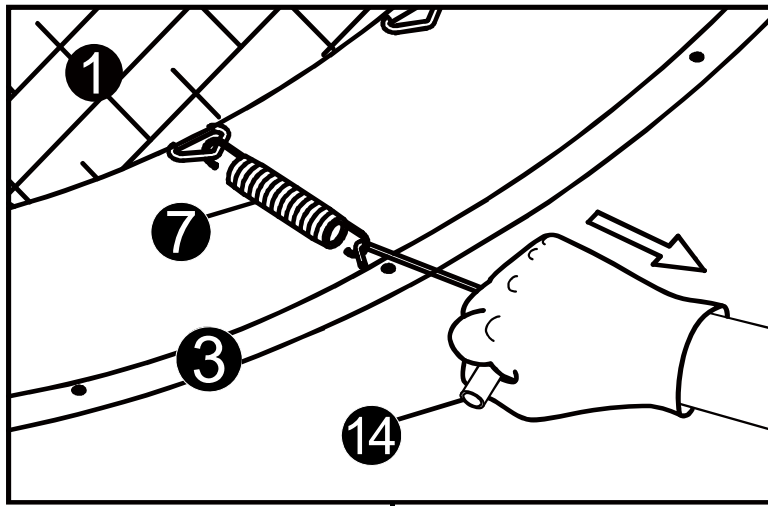

366

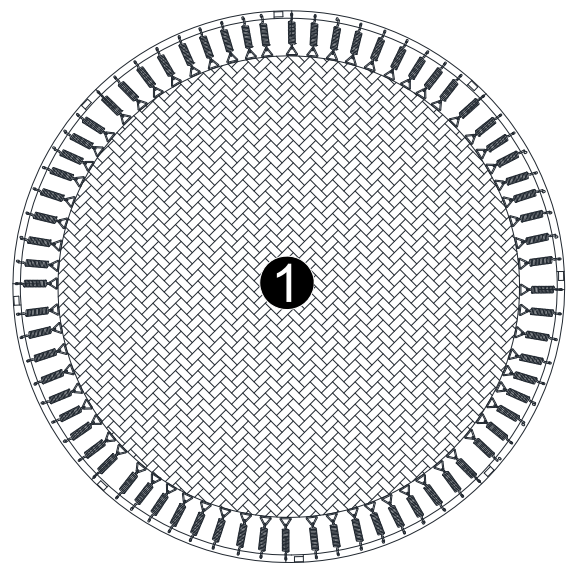
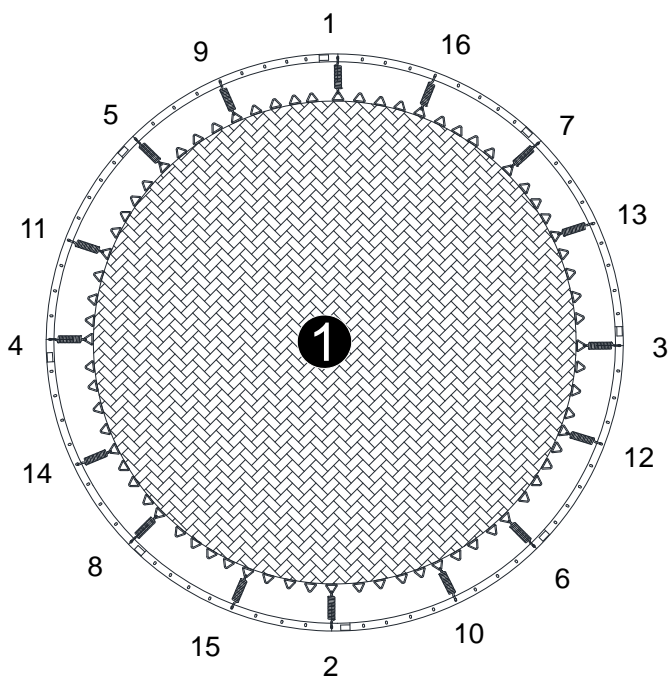
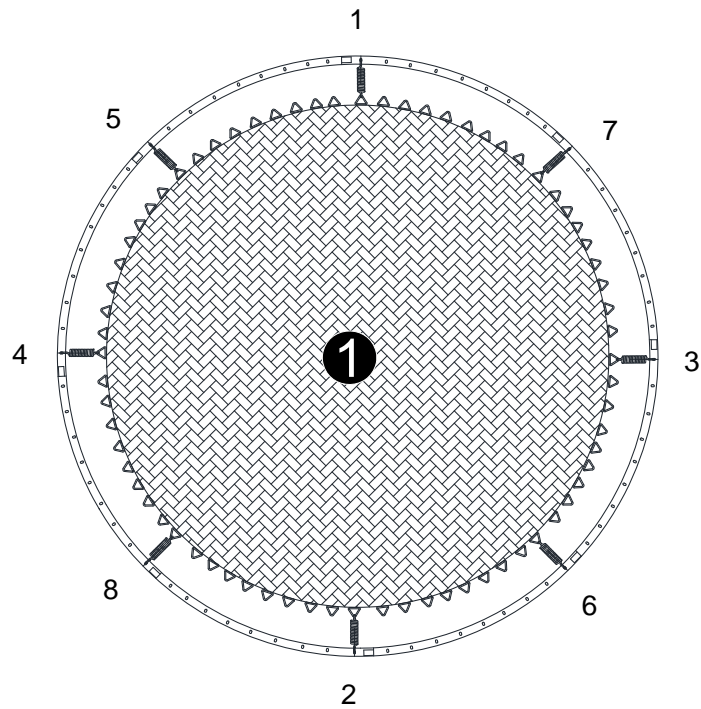

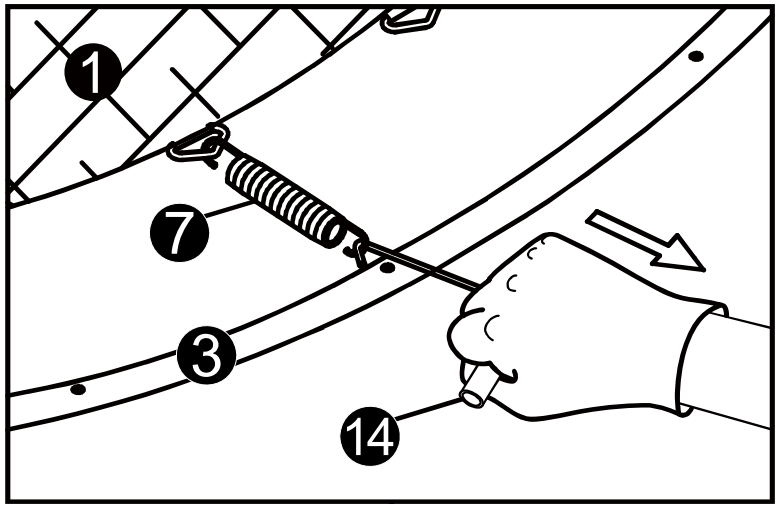

426

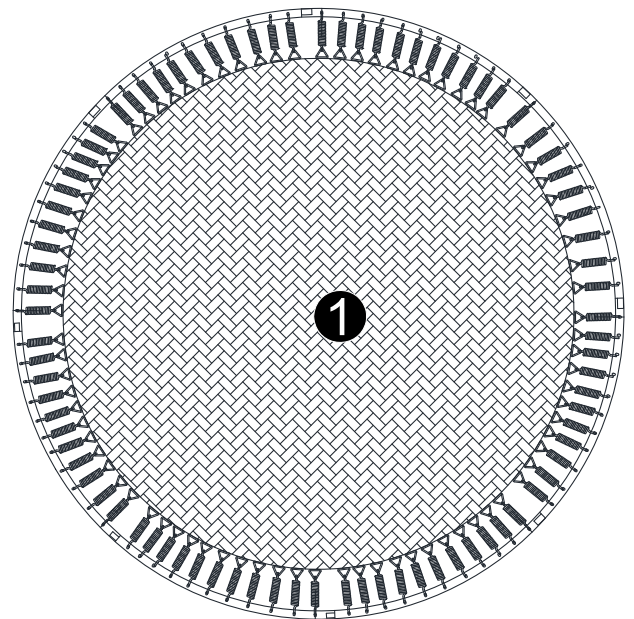
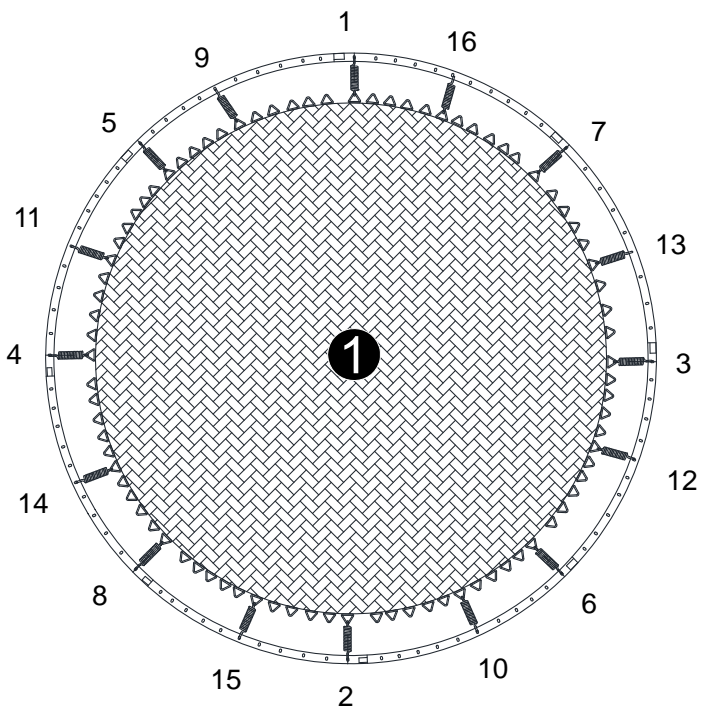
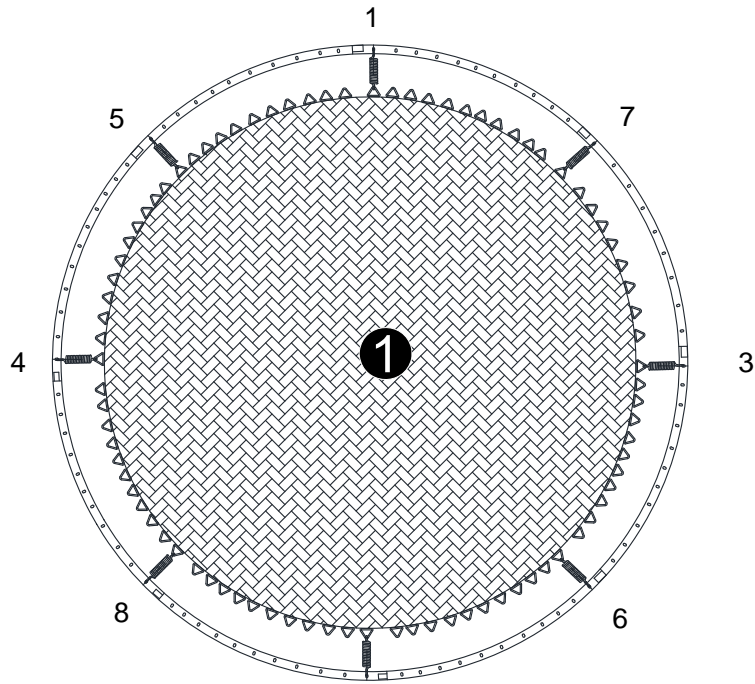

STEP 5

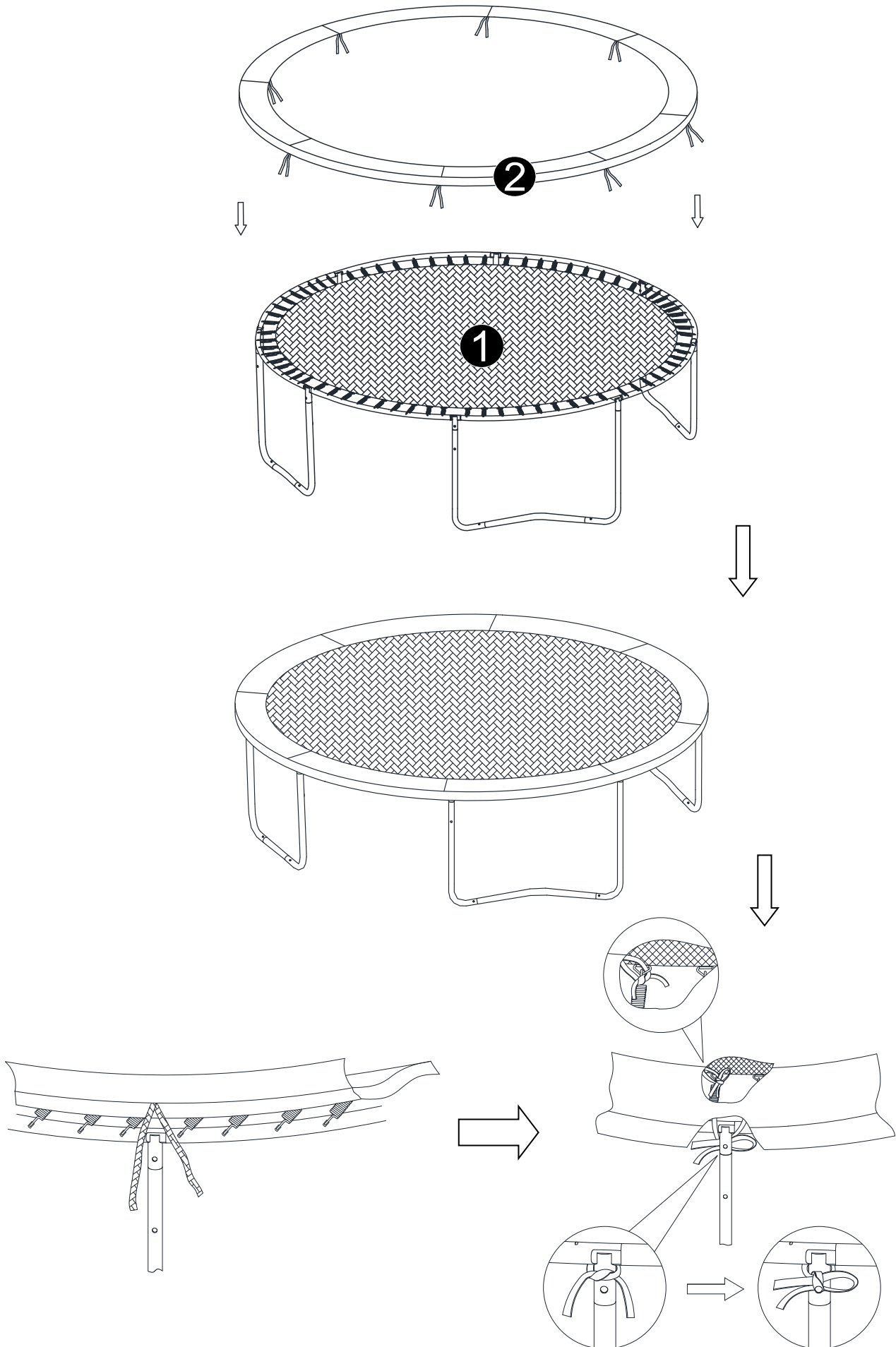

STEP 6

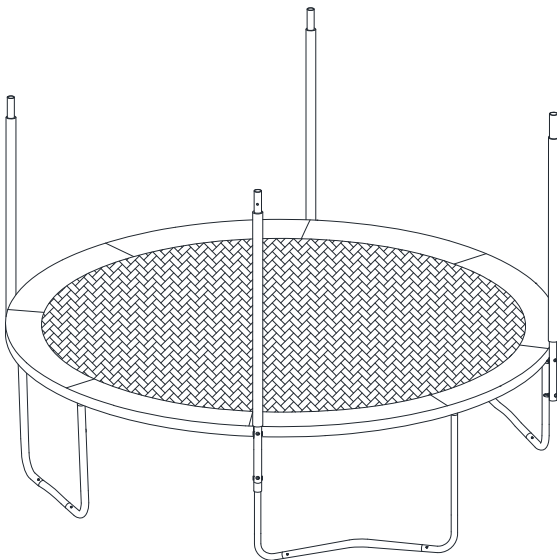
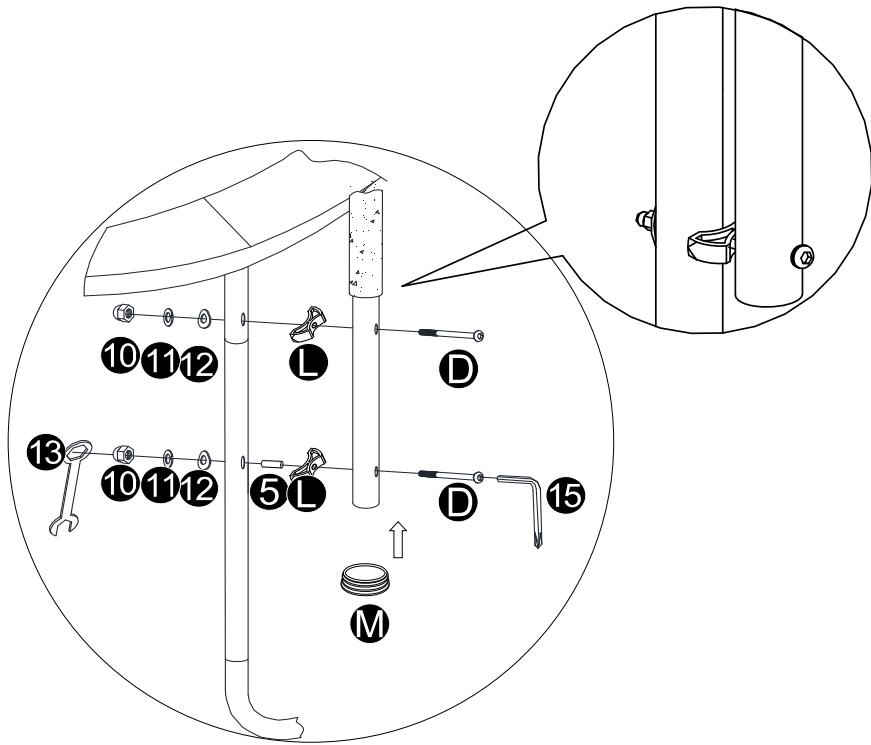

366

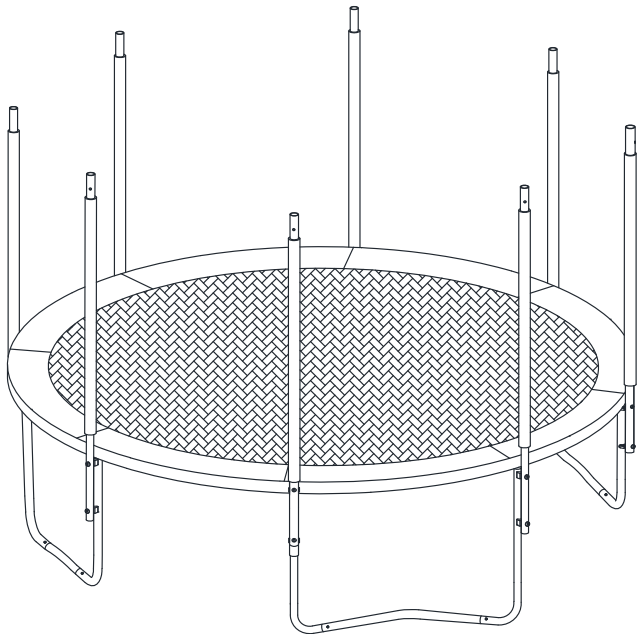

426

STEP 7

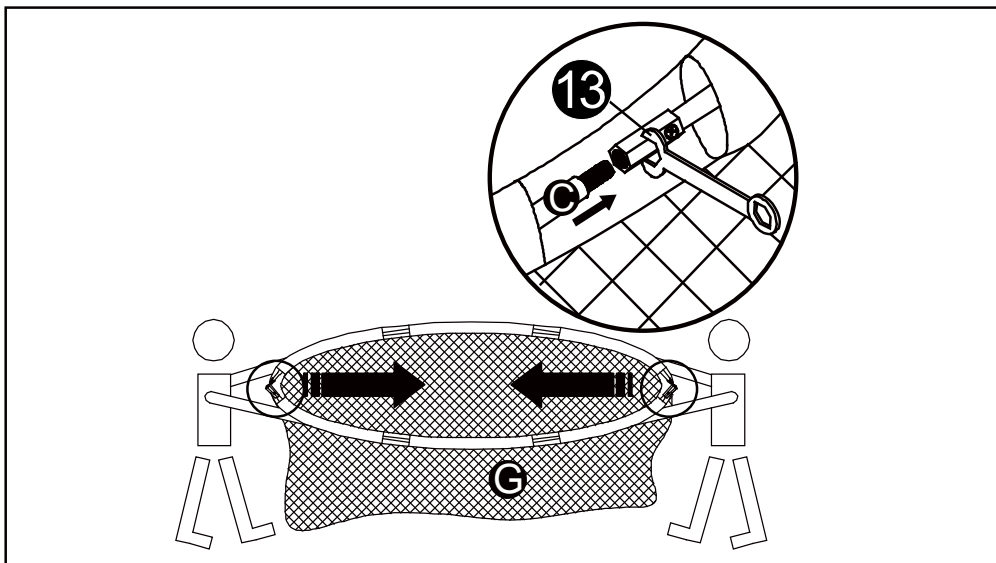
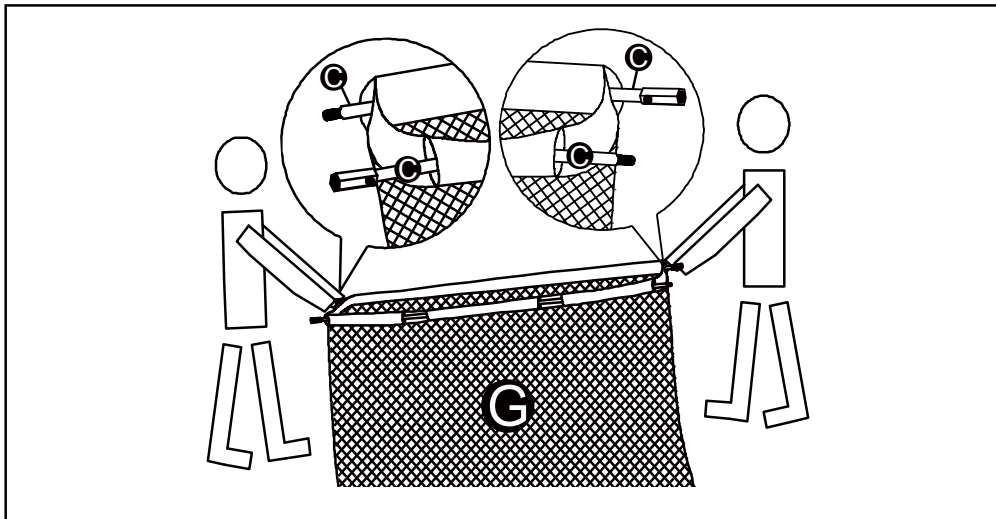
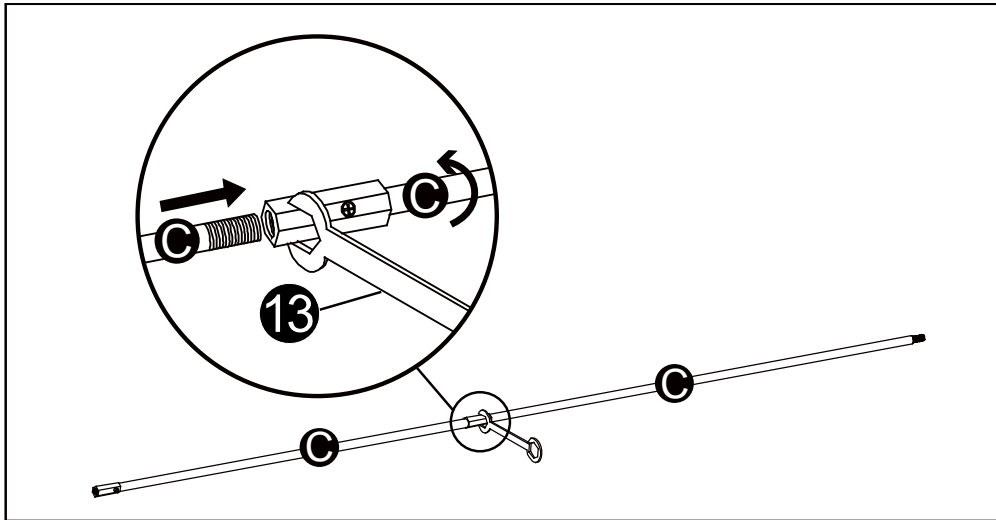

STEP 8

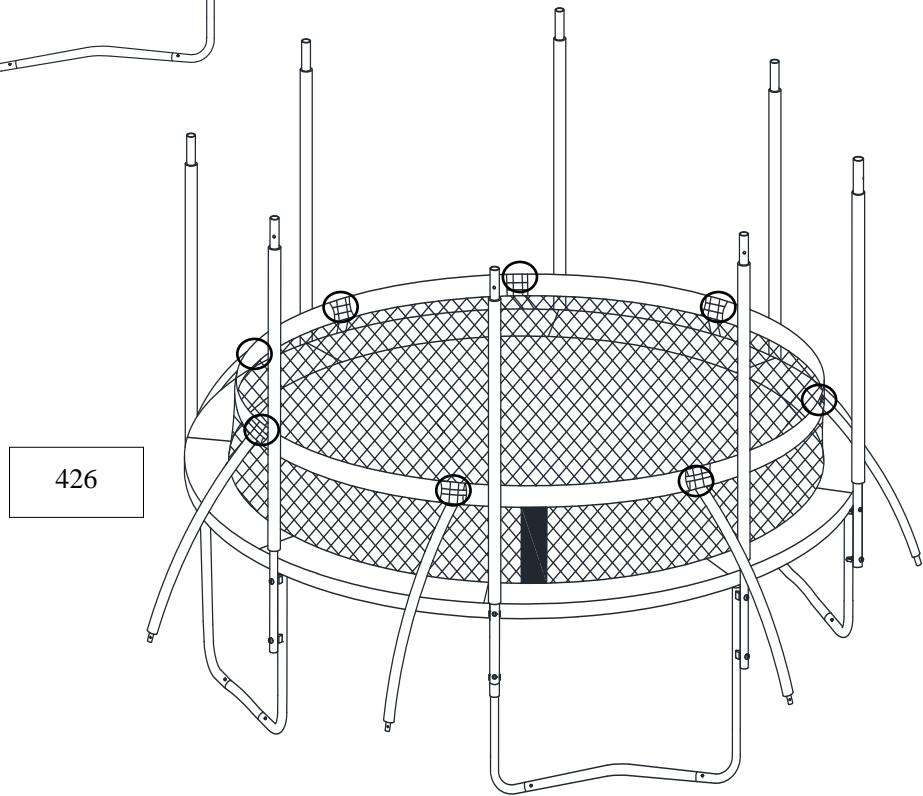
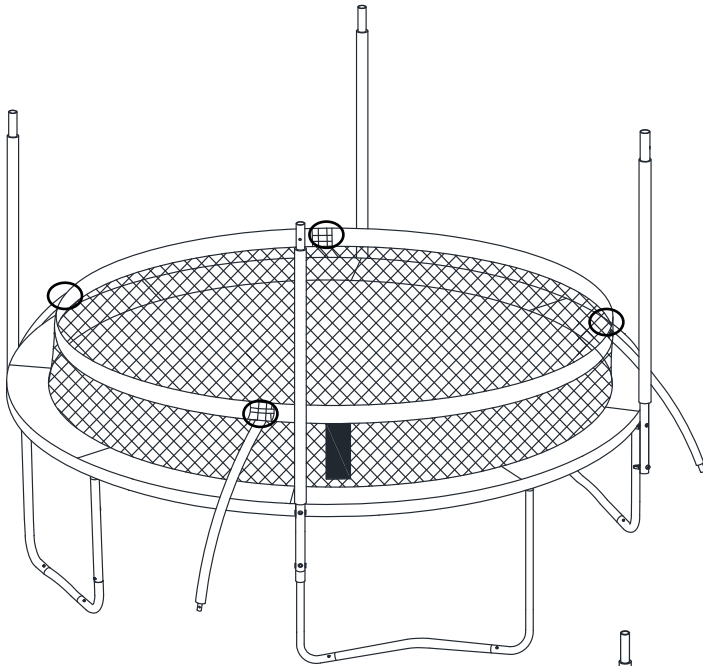
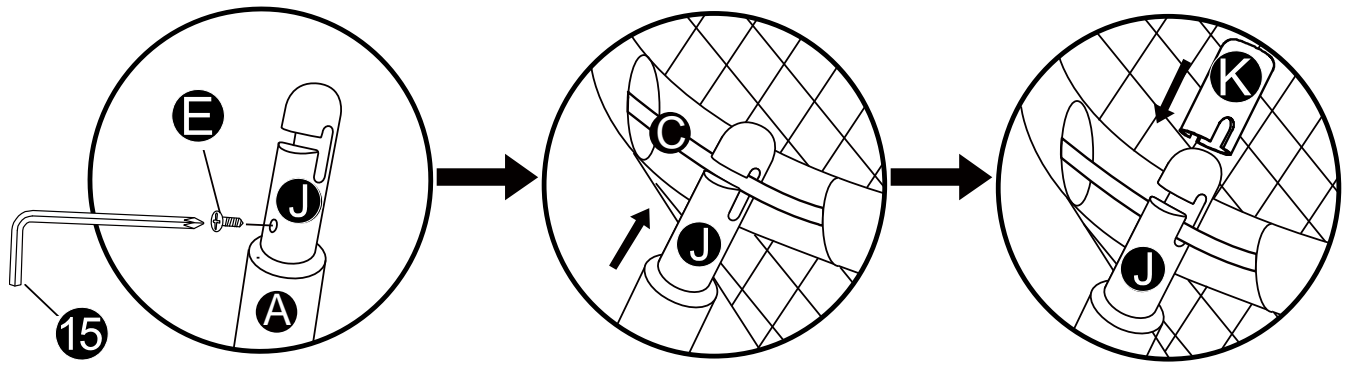

STEP 9

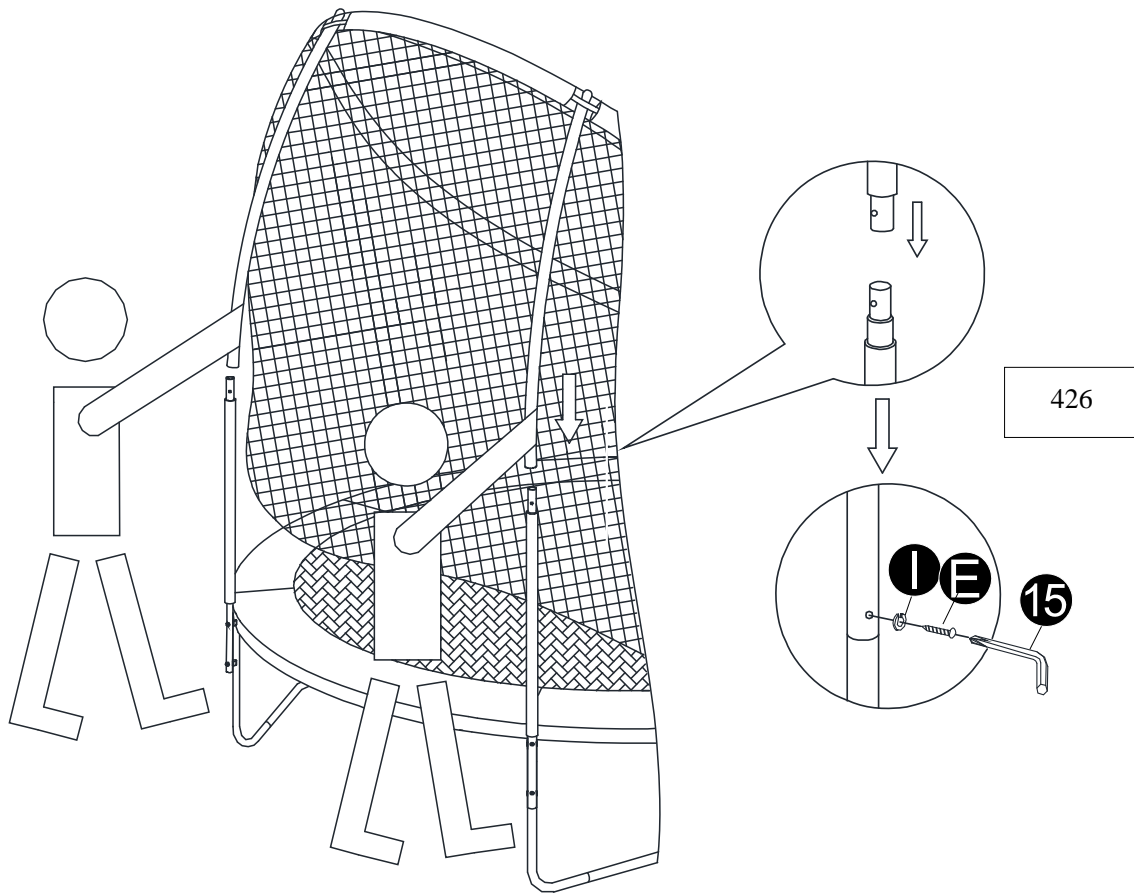
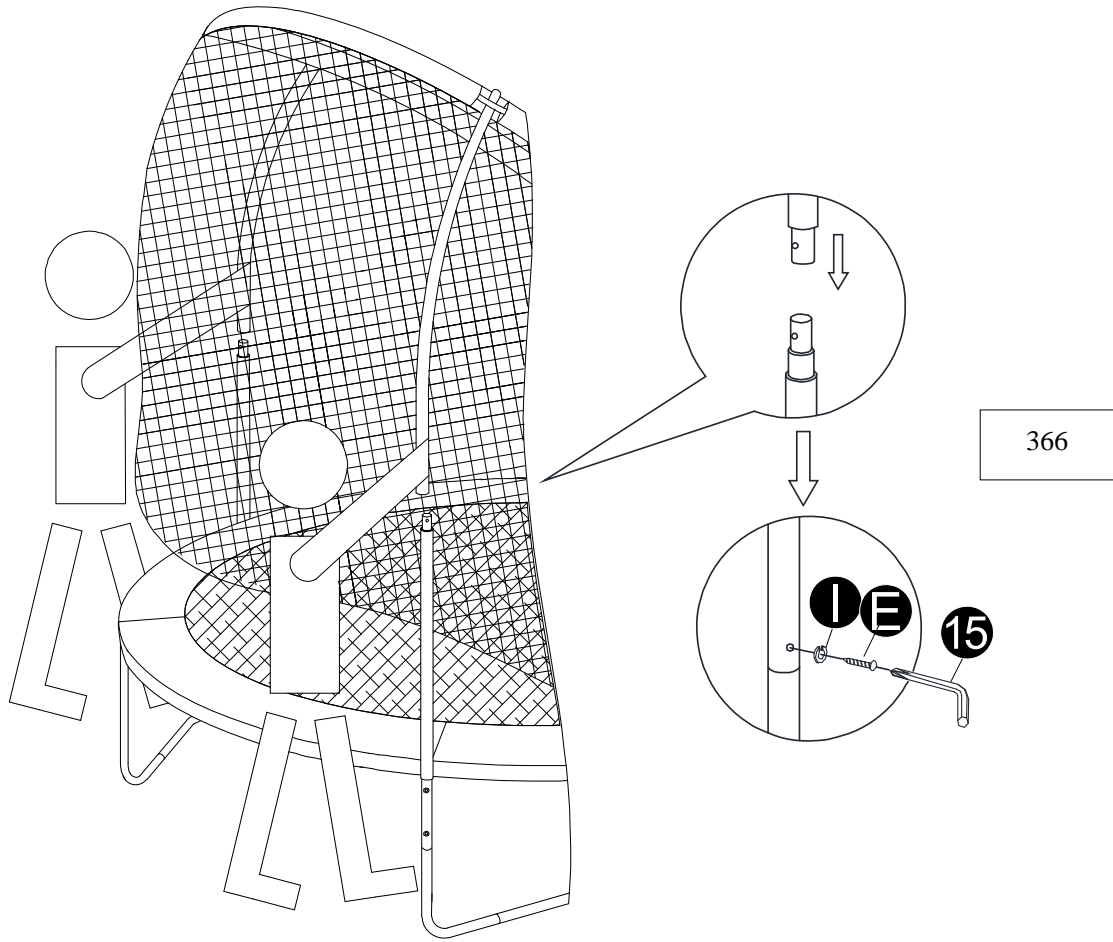

STEP 10

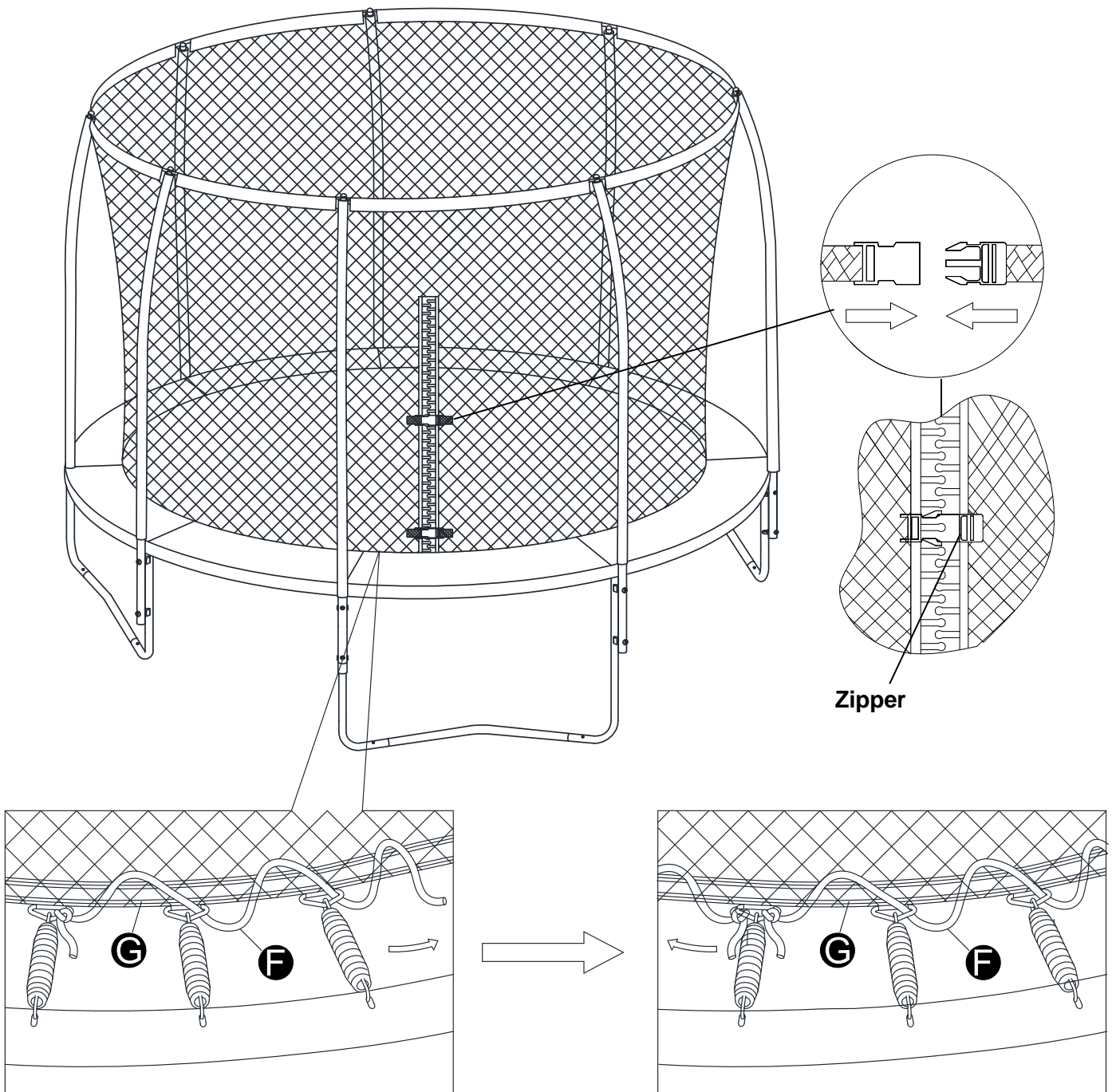

STEP 11

Important: Remember to go back and tighten all screws, nuts and buckles on both the Trampoline and the Enclosure Netting. Otherwise it may not function properly and may lead to injuries that could have been avoided by proper assembly.

The assembly of the trampoline is now complete. Remember to be careful when jumping.

BASIC TRAMPOLINE BOUNCES

THE BASIC BOUNCE

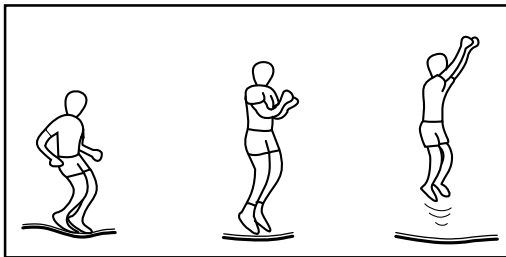

1. Start from standing position, feet shoulder width apart and with head up and eyes on mat.
2. Swing arms forward and up and around in a circular motion.
3. Bring feet together while in mid-air and point toes downward.
4. Keep feet shoulder width apart when landing

KNEE BOUNCE

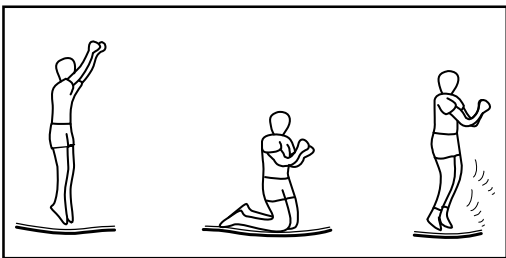

1. Start with basic bounce and keep it low.
2. Land on knees keeping back straight, body erects and uses your arms to maintain balance.
3. Bounce back to basic bounce position by swinging arms up.

SEAT BOUNCE

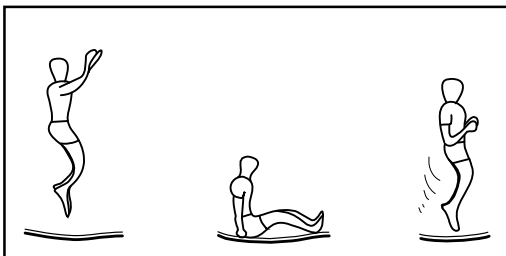

1. Land in a flat sitting position.
2. Place hands on mat besides hips, do not lock your elbow.
3. Return to erect position by pushing with hands.

FRONT BOUNCE

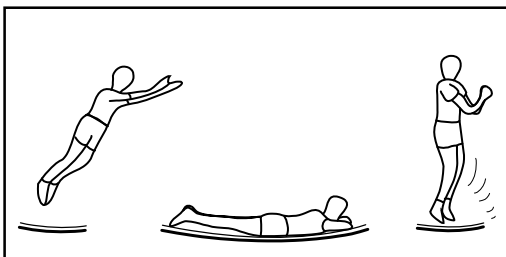

1. Start with a low bounce.
2. Land in prone (face down) position and keep hand and arms extended forward on mat.
3. Push off the mat with arms to return to standing position.

180 DEGREE BOUNCE

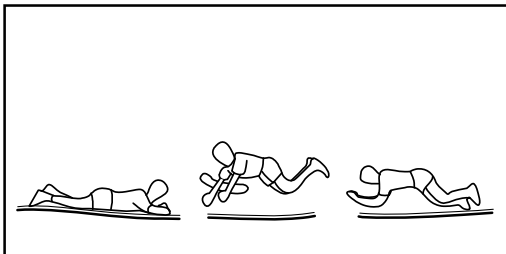

1. Start with front bounce position.
2. Push off with left or right hands and arms (depending on which way you wish to turn).
3. Maintain head and shoulders in the same direction and keep back parallel to mat and head up.
4. Land in prone position and return to standing position by pushing up with hands and arms.

WARNING:

ALWAYS START YOUR JUMP AT THE CENTER OF THE MAT. WHEN YOU LAND MORE THAN 30 CM AWAY FROM THE LOGO, STOP YOUR JUMP IMMEDIATELY! RESTART YOUR JUMP AT THE CENTER OF THE MAT.

NOTE:

MAKE SURE ALL BUCKLES AND ZIPPERS ARE CORRECTLY CLOSED DURING ANY USE OF THE TRAMPOLINE.

CARE AND MAINTENANCE

This trampoline was designed and manufactured with quality materials and craftsmanship. If proper care and maintenance is provided, it will provide all jumpers with years of exercise, fun, and enjoyment as well as reduce the risk of injury. Please follow the guidelines listed below. Installments of additional accessories must be carried out as per manufacturer's instructions.

This trampoline is designed to withstand a certain amount of weight and use. Please make sure that only one person at any one time uses the trampoline. Jumpers should either wear socks, gymnastics shoes, or be barefoot when using the trampoline. Please be aware that street shoes or tennis shoes should NOT be worn while using the trampoline. In order to prevent the trampoline mat from getting cut or damaged please do not allow any pets onto the mat. Also, jumpers should remove all sharp objects from their person prior to using the trampoline. Any type of sharp or pointed objects should be kept off the trampoline mat at all times. Regularly check that nuts and bolts are securely tightened, since they may come loose over time. Check that all spring-loaded (pit pin) joints are still intact and cannot become dislodged during play; Check all coverings and sharp edges and replace when required Check that mat, padding and enclosure are free from defects.

Always inspect the trampoline before each use for worn, abused or missing parts. A number of conditions could arise that may increase your chances of getting injured. Please be aware of:

- Punctures, holes, or tears in the trampoline mat
- Sagging trampoline mat
- Loose stitching or any kind of deterioration of the mat
- Bent or broken frame parts, such as the legs
- Broken, missing, or damaged springs
- Damaged, missing, or insecurely attached frame pad
- Protrusions of any types (especially sharp types) on the frame, springs, or mat

Note. Sunlight, rain, snow and extreme temperatures reduce the strength of these parts over time.

IF YOU FIND ANY OF THE PREVIOUS CONDITIONS, OR ANYTHING ELSE THAT YOU FEEL COULD CAUSE HARM TO ANY USER, THE TRAMPOLINE SHOULD BE DISASSEMBLED OR SECURED FROM USE UNTIL THE CONDITION (S) HAS BEEN RESOLVED.

Do not modify the trampoline or any of its parts

The net should for safety's sake be replaced every year.

MOVING THE TRAMPOLINE

If you need to move the trampoline, two people should be used. All connector points should be wrapped and secured with weather resistant tape, such as duct tape. This will keep the frame intact during the move and prevent the connector points from dislocating and separating. When moving, lift the trampoline slightly off the ground and keep it horizontal to the ground. For any type of other move, you should disassemble the trampoline.

Keep this instruction manual.

Produced by Crowntec(Jiang Xi)Sports Technology Co.,Ltd,
Intersection of West Blvd. and Jingyi Road, Gongqingcheng City, Jiujiang City.
Jiangxi Province,China.
office@crowntecgroup.com

Imported by Salling Group, Rosbjergvej 33, 8220 Brabrand.
sallinggroup.com

Samlevejledning

Trampolin – 366/426

144”(12FT)/ dia. 366cm x H.273cm

168”(14FT)/ dia. 426cm x H.273cm

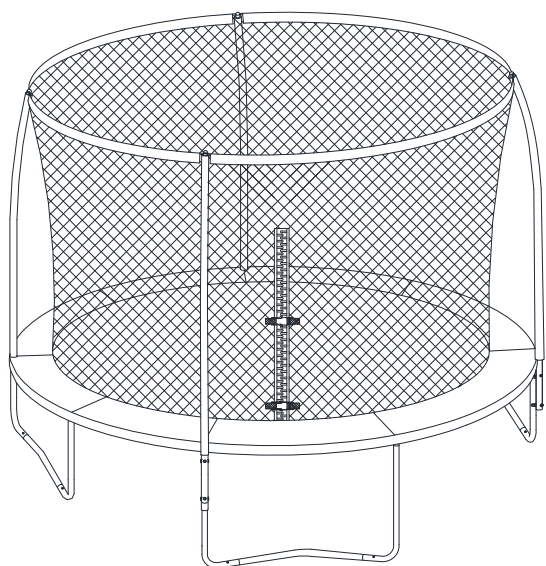

366cm

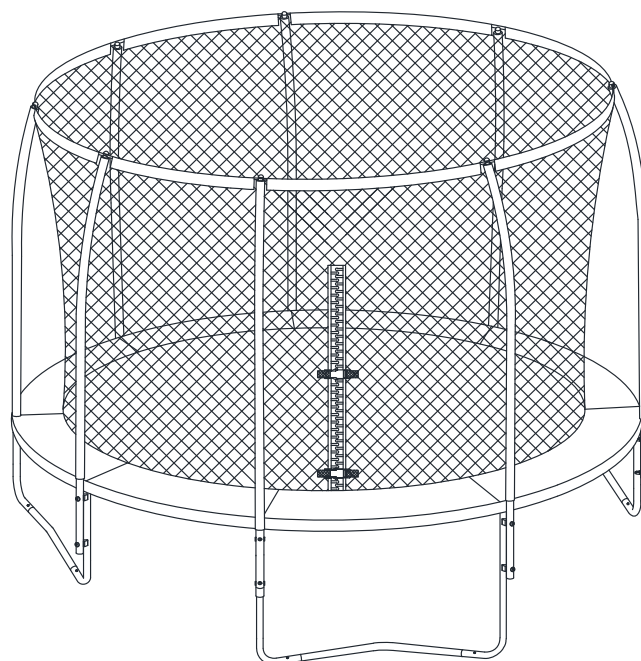

426cm

Det er meget vigtigt, at du læser og forstår vejledningen, før trampolinen samles og anvendes.

Vi håber, at du bliver glad for at bruge trampolinen. En trampolin er rigtig sjov og giver god motion på samme tid. Det tager lidt tid at samle den, men det er lettere, hvis du læser alle anvisninger, før du starter. Det kan tage over en time at samle trampolinen, så vær tålmodig, og få en til at hjælpe dig.

VIGTIGT

Læs følgende erklæring og advarsler for at undgå alvorlige eller fatale ulykker.

Advarsel.

- Maks. 100 kg.
- Kun til privat brug.
- Til udendørs brug.
- Kun en bruger ad gangen. Risiko for kollision.
- Nettet bør udskiftes hvert år.
- Opsyn af en voksen er påkrævet.
- Lav ikke saltomtaler. Det er meget farligt, og du risikerer alvorlige skader eller dødsfald.
- Luk altid sikkerhedsnettets åbning, inden du begynder at hoppe.
- Læs vejledningen.
- Trampolinen skal samles af en voksen ifølge samlevejledningen og derefter tjekkes før brug.
- Hop kun i gymnastiksko eller med bare fødder.
- Tøm lommerne, og hav ikke noget i hænderne.
- Hop altid på midten af dugen.
- Må ikke bruges, hvis dugen er våd.
- Spis ikke, når du hopper
- Hop aldrig ned fra trampolinen.
- Benyt trampolinen i begrænset tid (hold jævnlige pauser).
- Må ikke bruges i stærk blæst. Fastgør trampolinen.
- Forsøg ikke at springe over nettet.
- Hop ikke ind i nettet med vilje.
- Forsøg ikke at hoppe tilbage fra nettet igen med vilje.
- Hæng ikke oven på nettet, og forsøg ikke at klatre op i det.
- Tag smykker af, som kan vikles ind i nettet eller skære i det.

Placering af trampolinen

Placer aldrig trampolinen på et cementgulv eller andre hårde flader. Den bedste placering er på en jævn og stabil overflade som for eksempel en græsplæne. Der skal være et frit område på mindst to meter omkring trampolinen. Sørg for, at der ikke er nogen ledninger, grene, hegn eller andre mulige farer over og rundt om trampolinen. Trampolinen må ikke placeres tæt på pools, gynger, rutsjebaner, klatrestativer eller andre installationer, der udgør en risiko. Denne trampolin er ikke beregnet til nedgravning.

Vejrforhold

Trampolinen må ikke bruges, når den er våd. Skil trampolinen ad om vinteren, og opbevar alle stofdele (dug, skumkanter og sikkerhedsnet) indendørs. Fjern skumkanter og sikkerhedsnet ved stærk blæst, og fastgør trampolinen til jorden med plækker/jordspyd (sælges separat).

Vejledning

Start langsomt. Forsøg ikke at lave svære øvelser.

Hop ikke i trampolinen, når du er trætet. Det øger risikoen for skader. Sørg for at bære passende fodtøj, f.eks. gymnastiksko, eller hop med bare fødder.

Træd aldrig på sikkerhedsbetrækket. Det er ikke konstrueret til at kunne bære en persons vægt.

Når du skal ned fra trampolinen, må du aldrig hoppe. Kravl altid af. Hop aldrig i trampolinen, hvis du har indtaget stoffer eller alkohol.

Der skal altid være andre til stede, når du hopper i trampolinen. Så er der nogen til at hjælpe dig, hvis du skulle komme til skade.

Begynd altid med at hoppe midt i cirklen. Hvis du lander mere end 30 cm fra kanten af logoet, skal du omgående holde op med at hoppe!











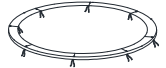

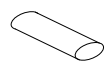
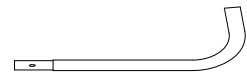
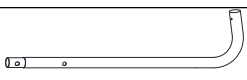
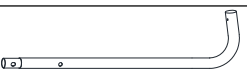
Begynd at hoppe på midten af dugen igen.

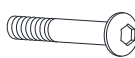
Montering



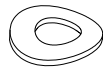









Læs samlevejledningen omhyggeligt, før du begynder at samle trampolinen. Det kan anbefales, at to personer hjælpes ad med at samle trampolinen.

Begynd med at kontrollere, at du har alle de nødvendige dele. Hver dels referencenummer vil blive brugt her i vejledningen som en hjælp til dig.

Oversigt over dele (trampolin)

Delnr.	Dele	Beskrivelse	366cm Antal	426cm Antal
1		Trampolindug med påsyede trekantringe	1	1
2		Sikkerhedsbetræk	1	1
3		Topramme med benfæster	8	8
4		Benbase	4	4
5		Forstærket stål	4	8
6A		Højre L-formet ben - (2 huller)	4	0
6A		Højre L-formet ben - (3 huller)	0	4
6B		Venstre L-formet ben - (3 huller)	4	4
7		Galvaniserede fjedre	72	88
8		Lang Bolt (50mm)	4	0
9		Skrue (15mm)	8	8
10		Låsemøtrik	12	16
11		Fjederskive (stor)	20	24
12		Buet spændeskive	20	24
13		Skruenøgle	1	1
14		Fjedermonteringsværktøj	1	1
15		Unbrakonøgle	1	1

Enclosure Parts List

Part Number	Diagram	Description	366cm Quantity	426cm Quantity
A		Toprør med skum	4	8
B		Underrør med skum	4	8
C		Kabeltråd	12	12
D		Lang Bolt (79mm)	8	16
E		Selvlåsende skrue	8	16
F		Line	7	8
G		Sikkerhedsnet	1	1
I		Fjederskive (lille)	4	8
J		Plastikhætte	4	8
K		Kasket	4	8
L		Gap Spacer	8	16
M		Endestykke	4	8



HUSK AT BENYTTE HANDSKER UNDER SAMLING FOR AT UNDGÅ KLEMNING, OG DER SKAL VÆRE MINDST TO PESONER FOR AT SAMLE TRAMPOLINEN

Montering af trampolin

Trin 1

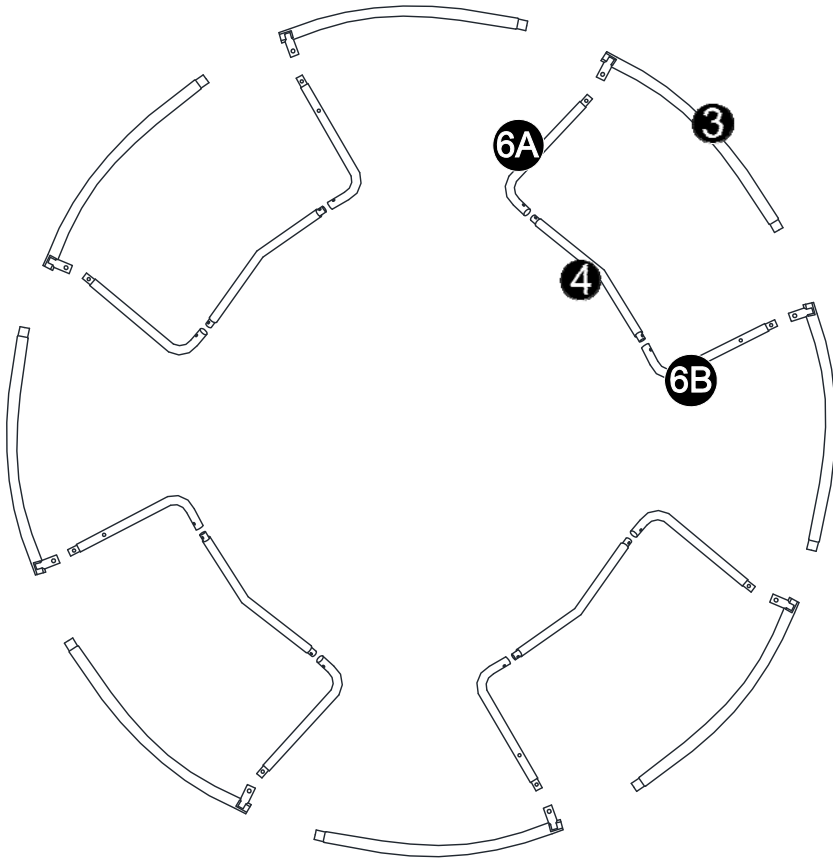

366

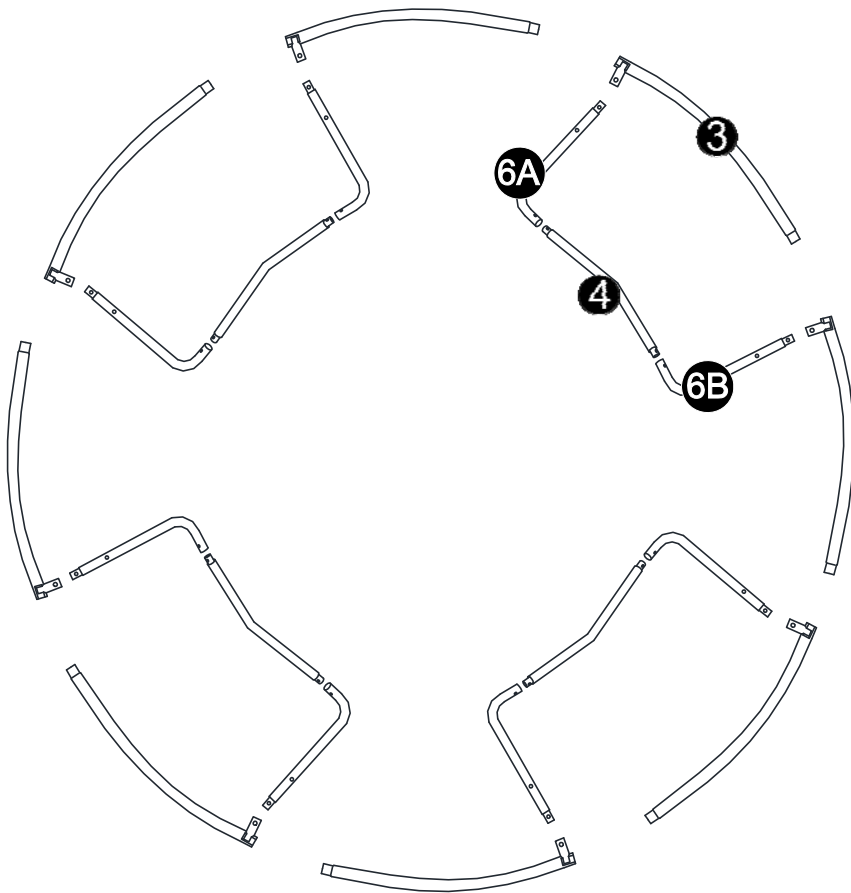

426

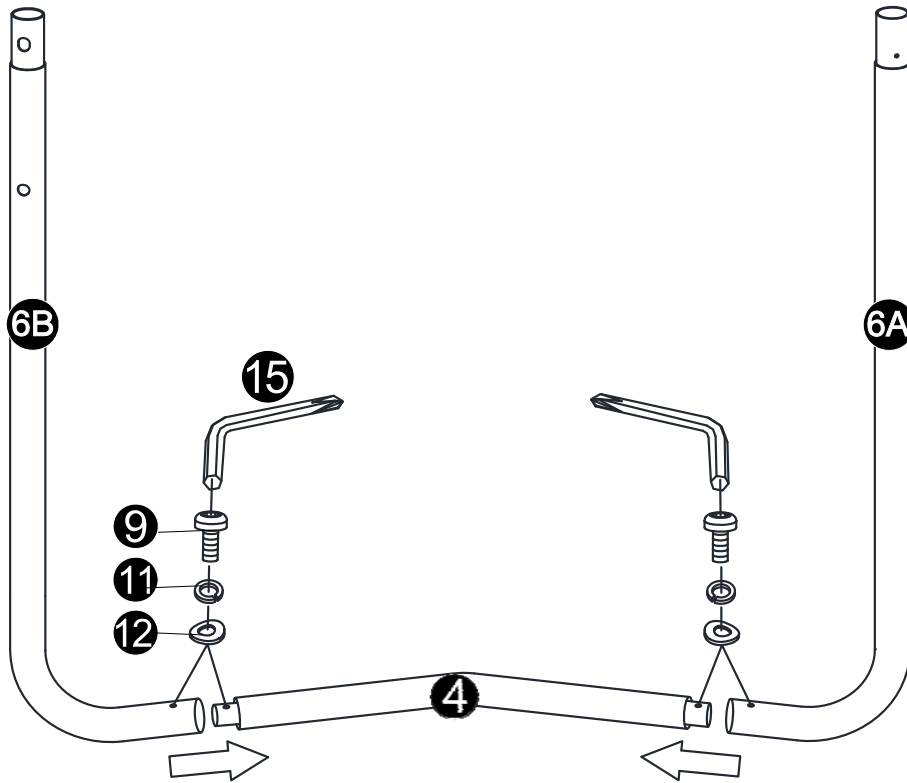

366

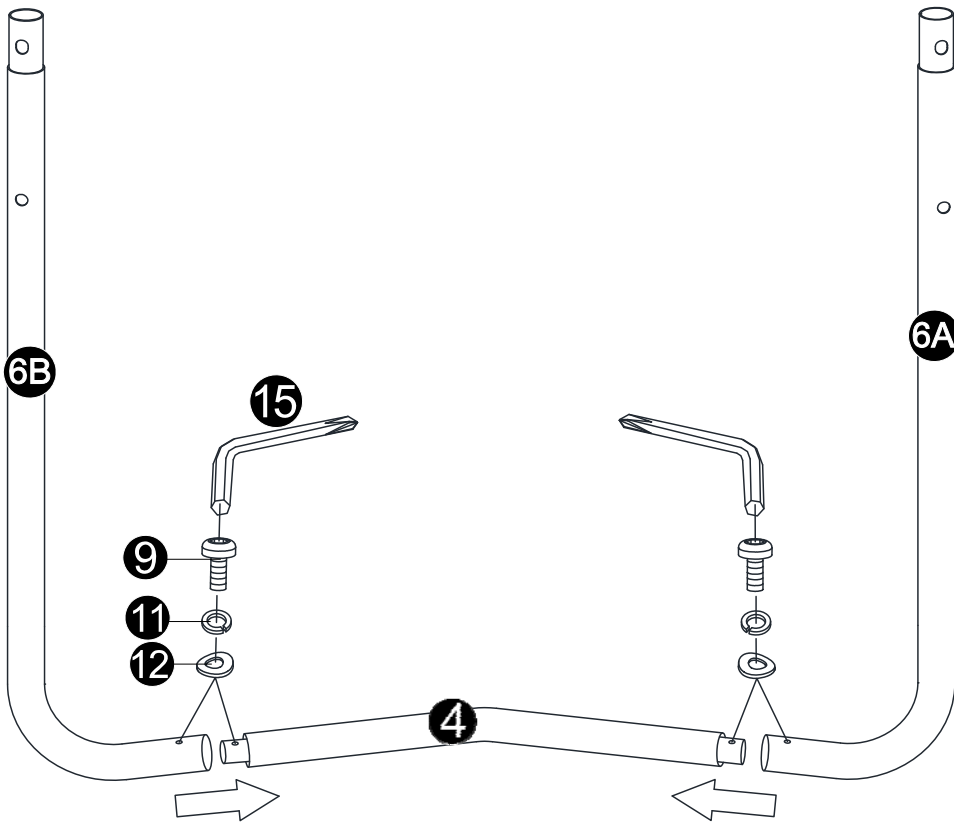

426

Trin 3

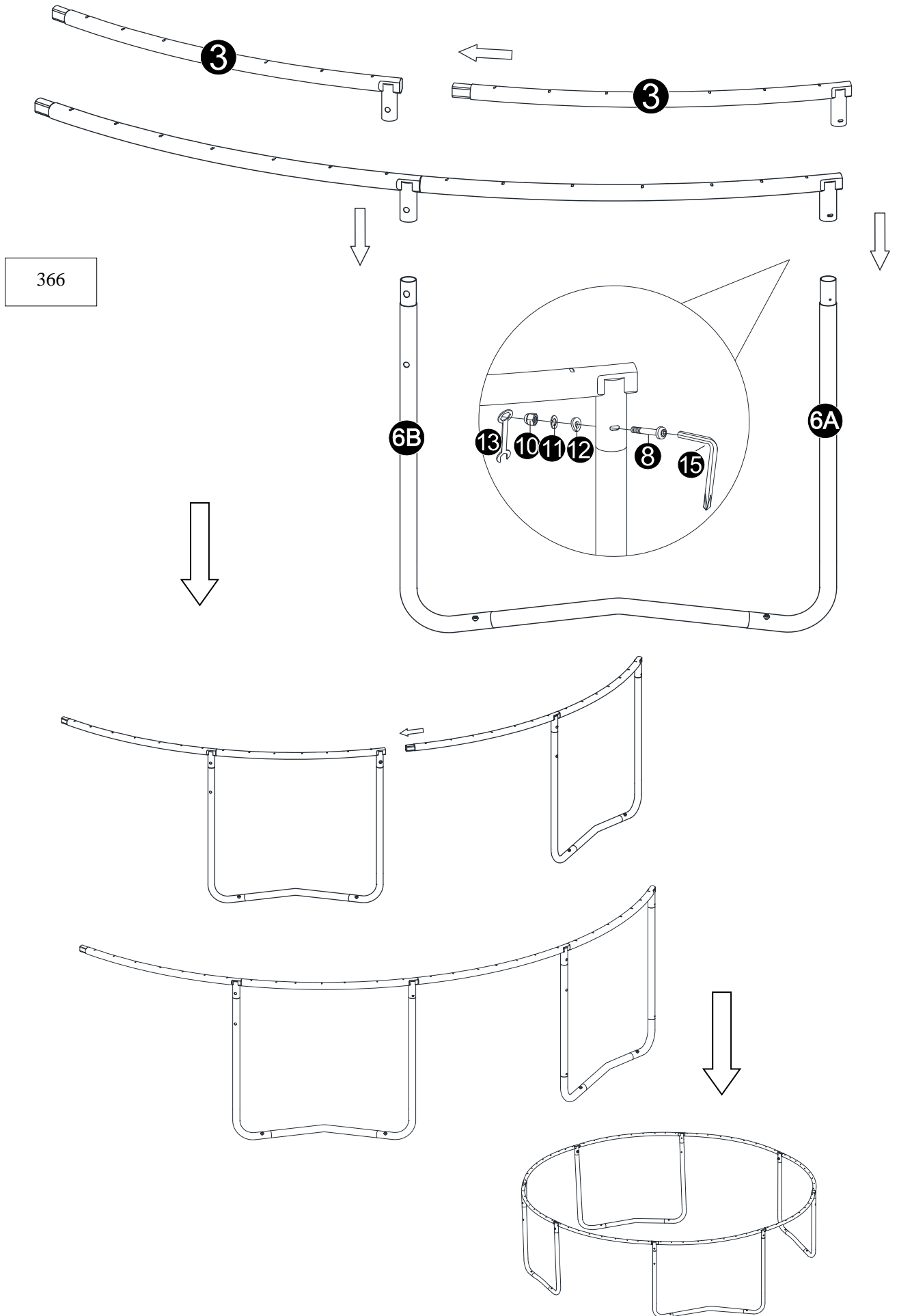

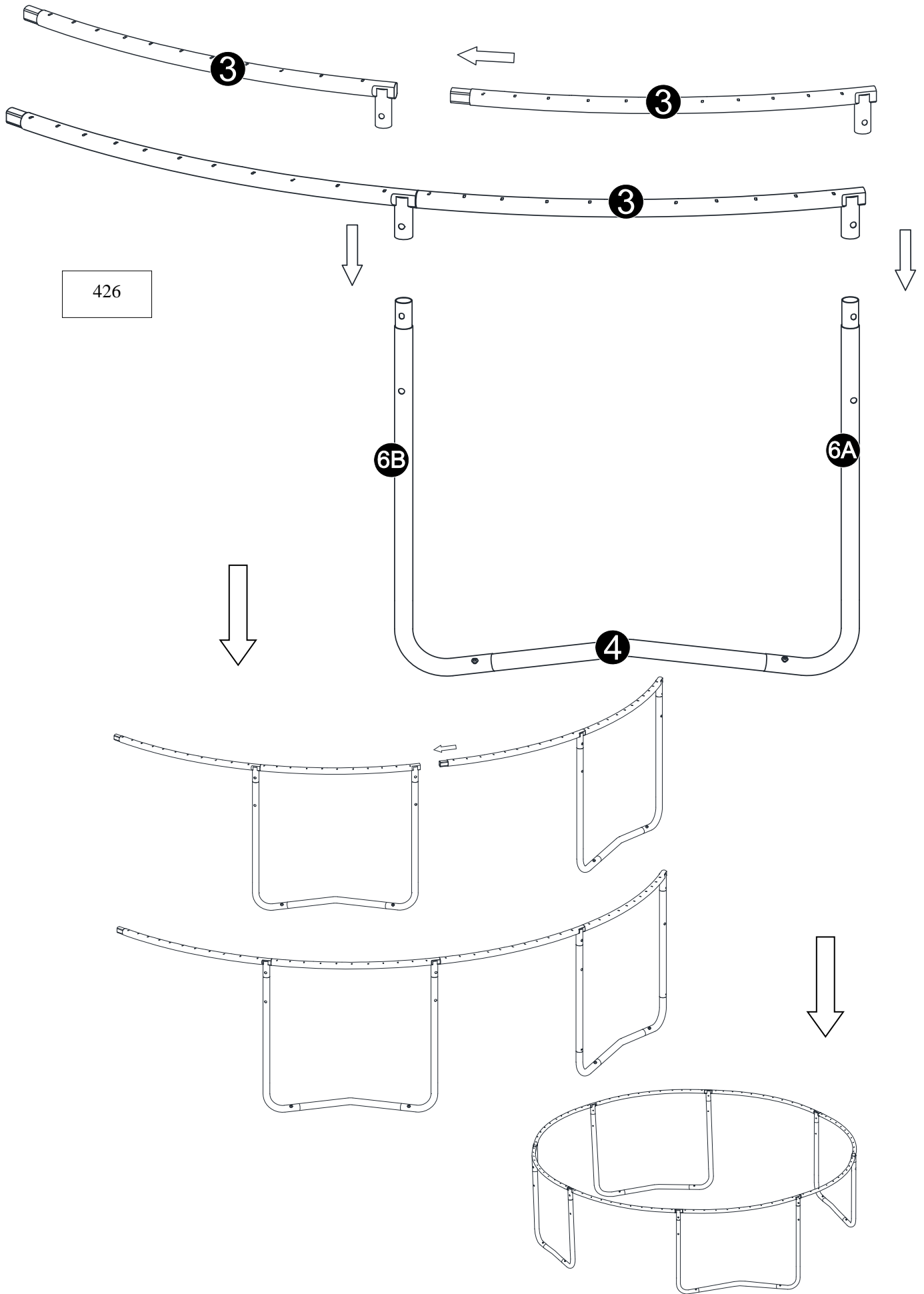

Trin 4

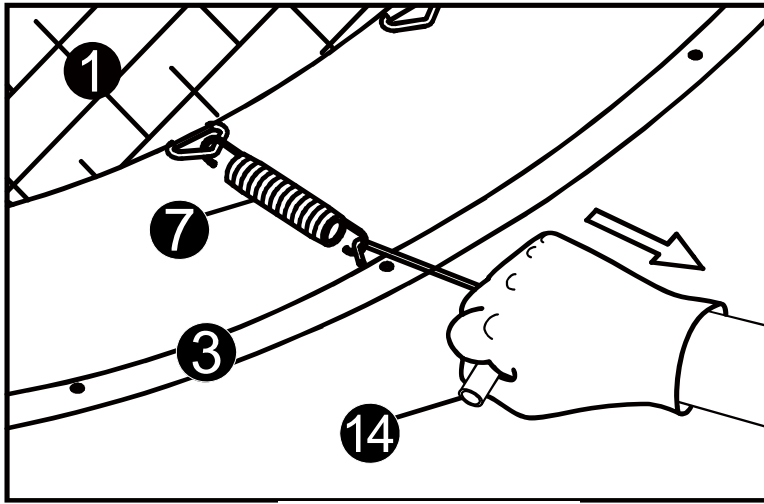

366

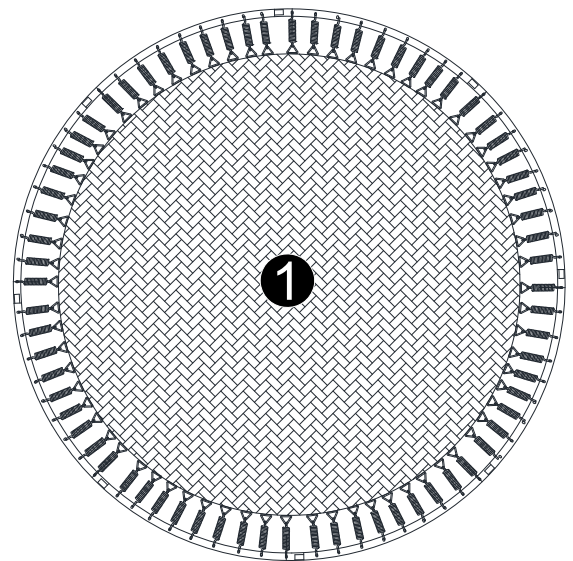
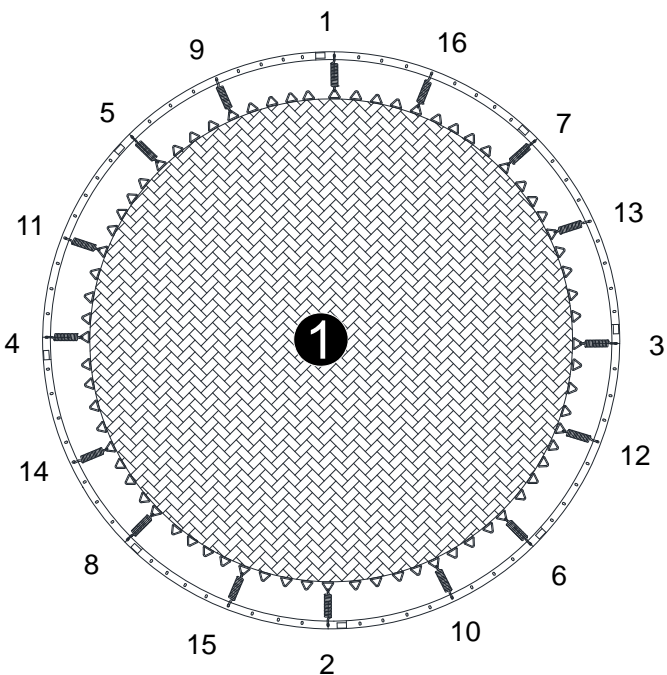
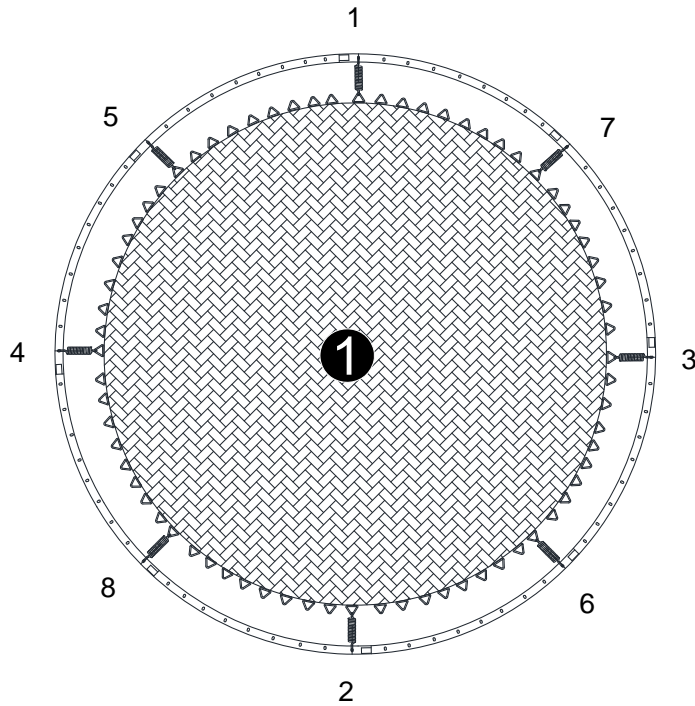

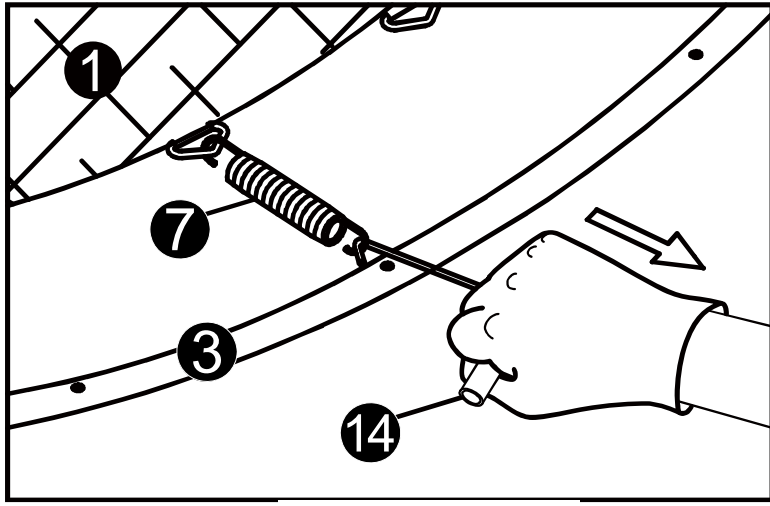

426

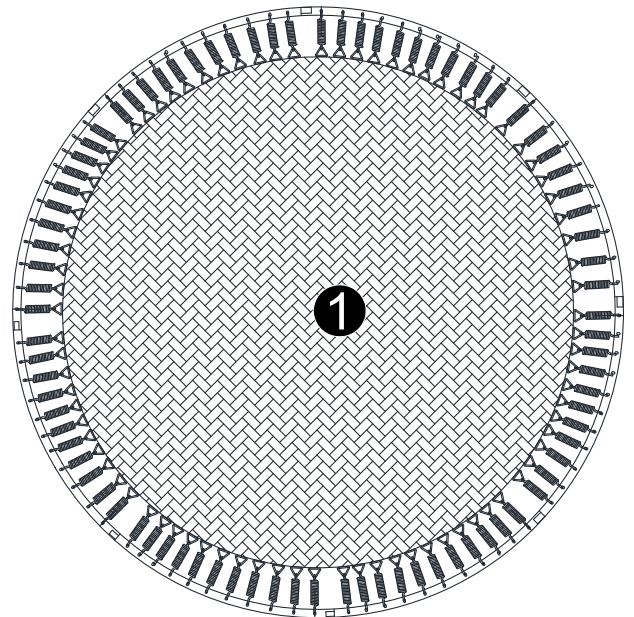
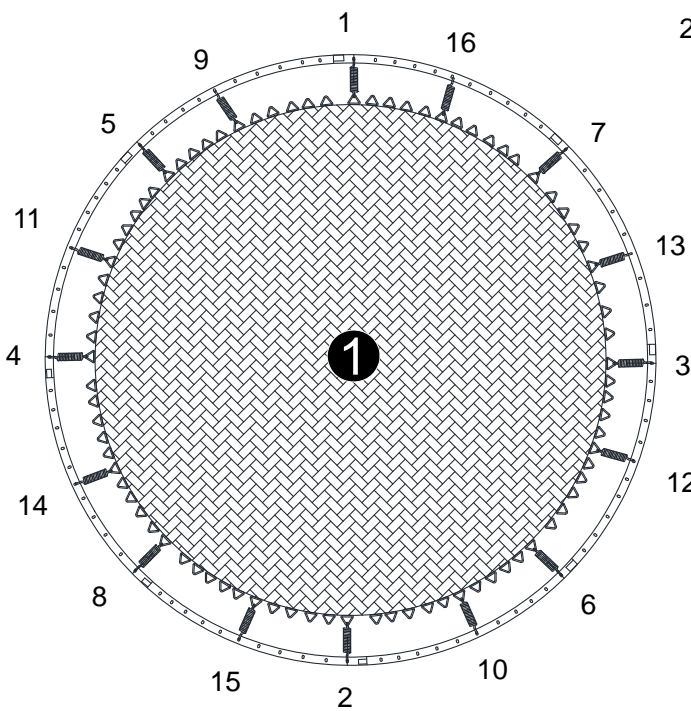
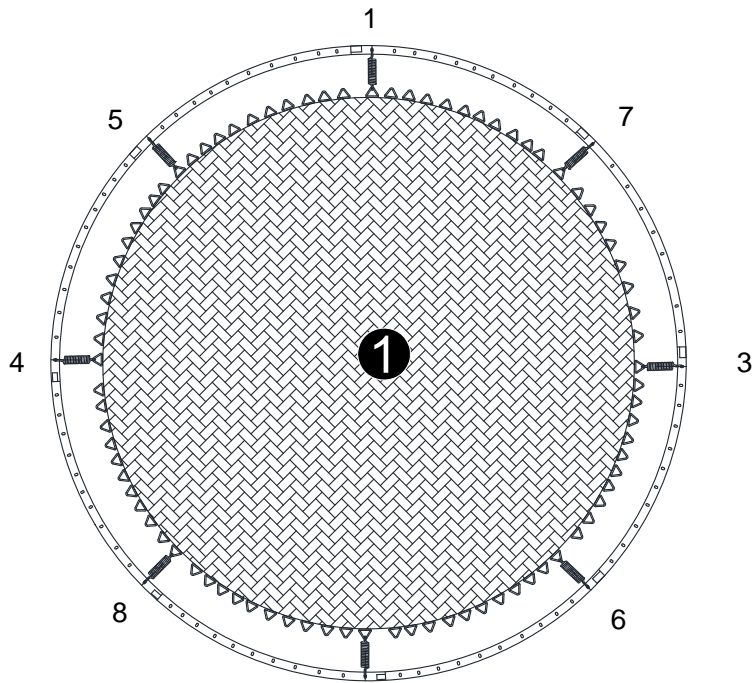

Trin 5

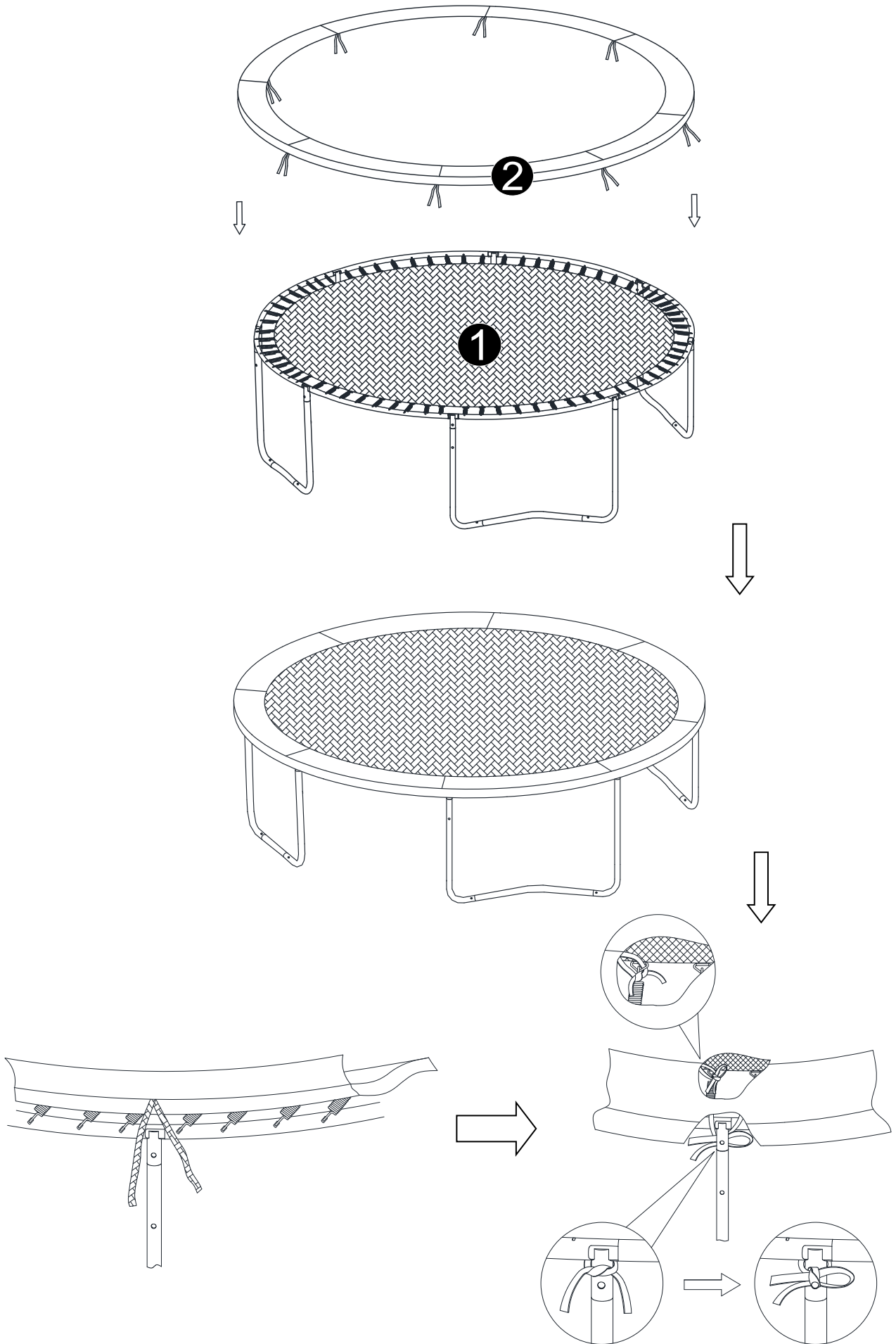

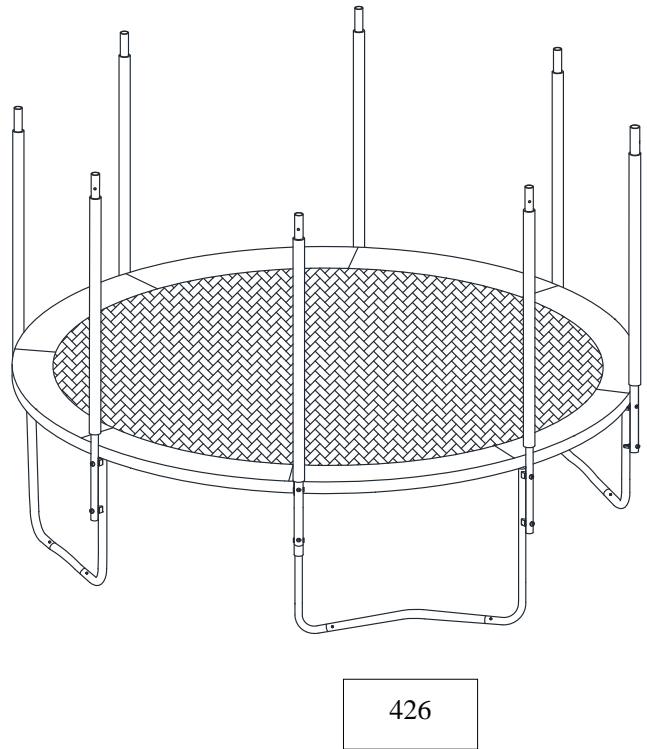
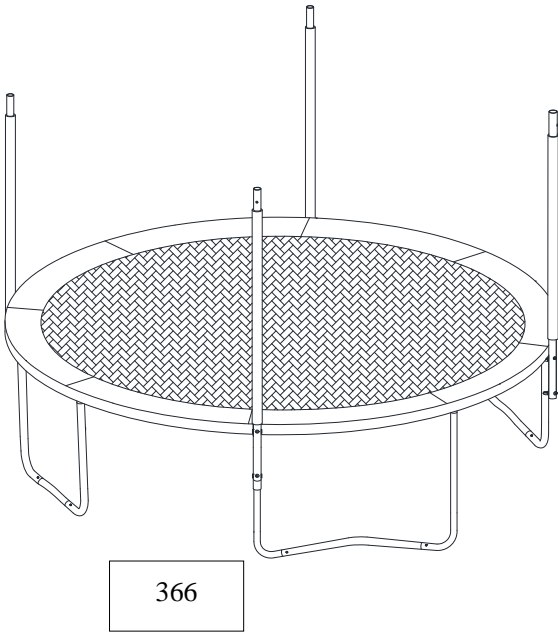
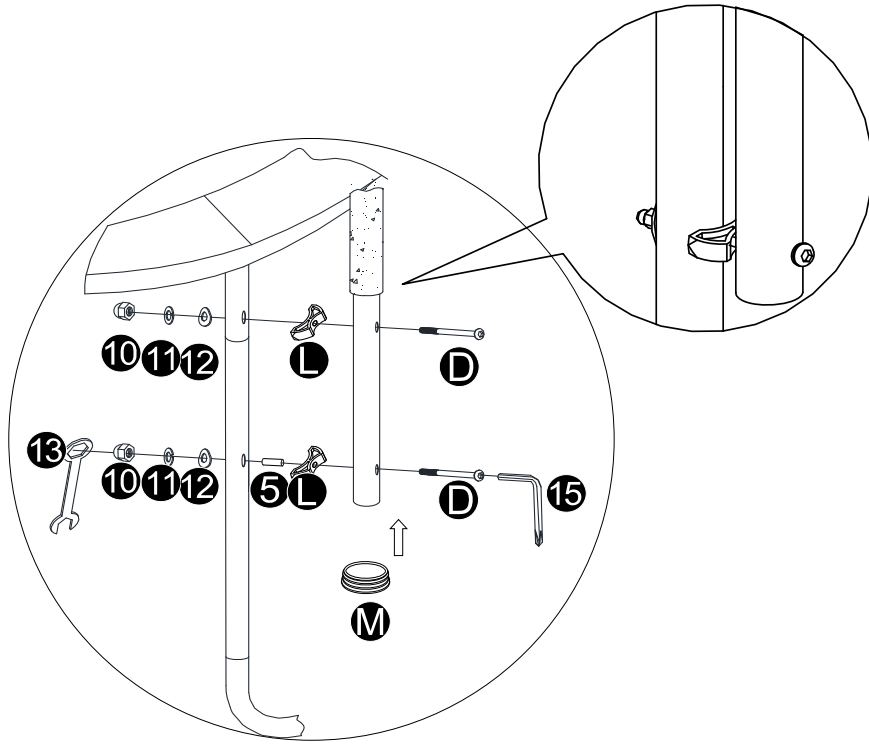

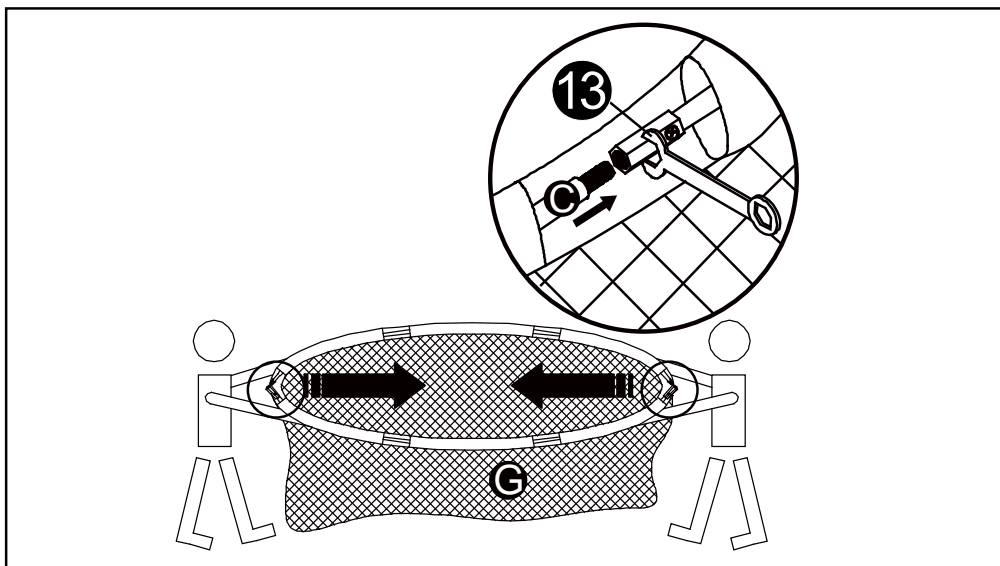
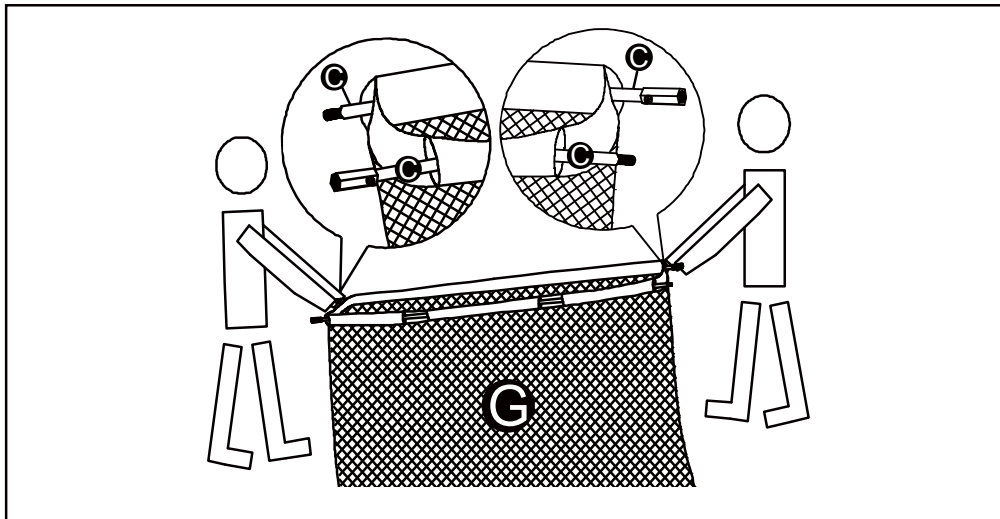
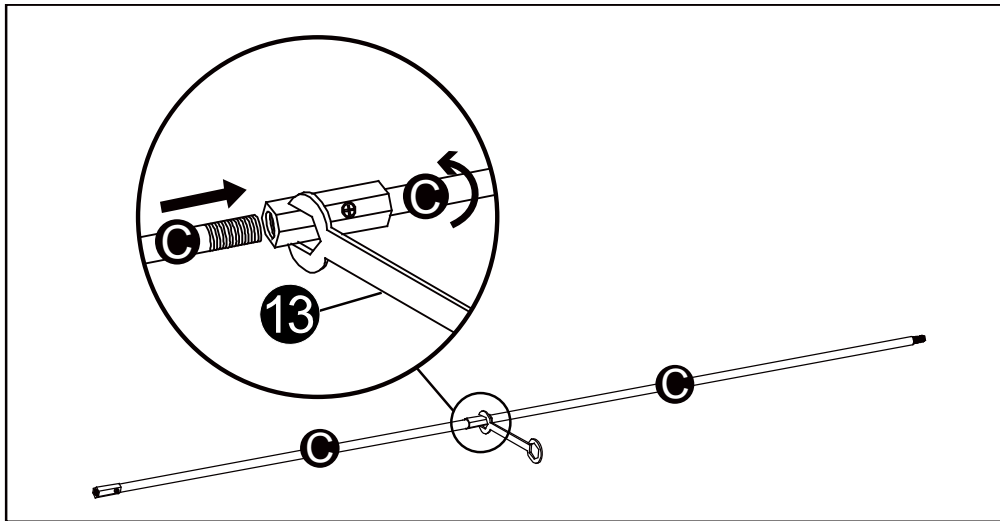

Trin 8

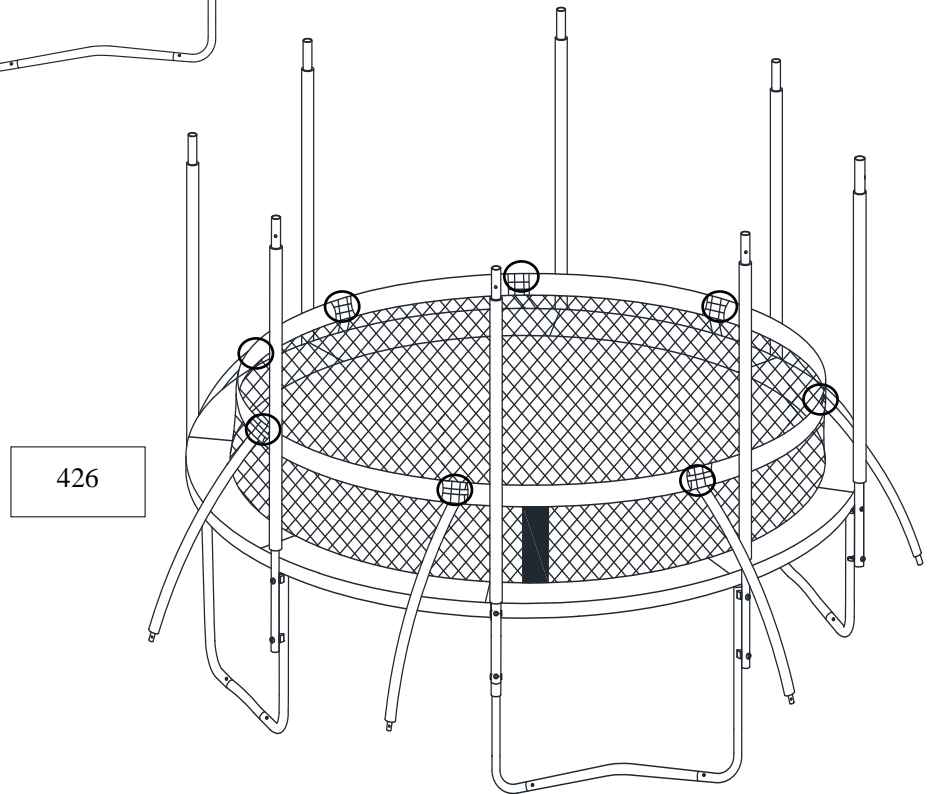
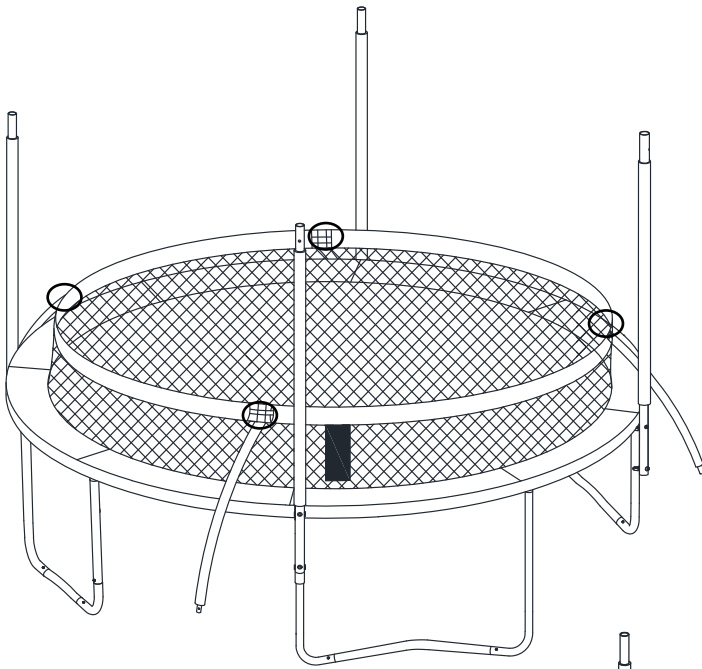
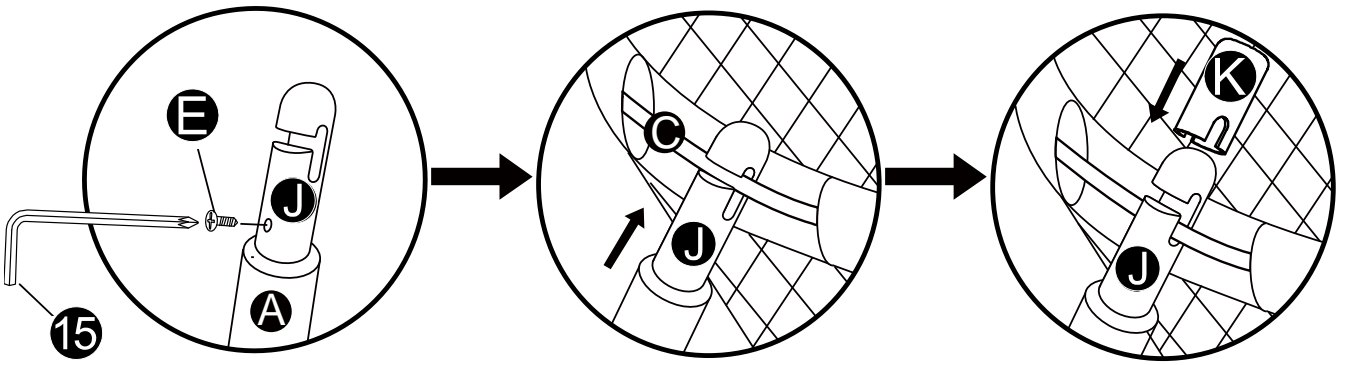

Trin P 9

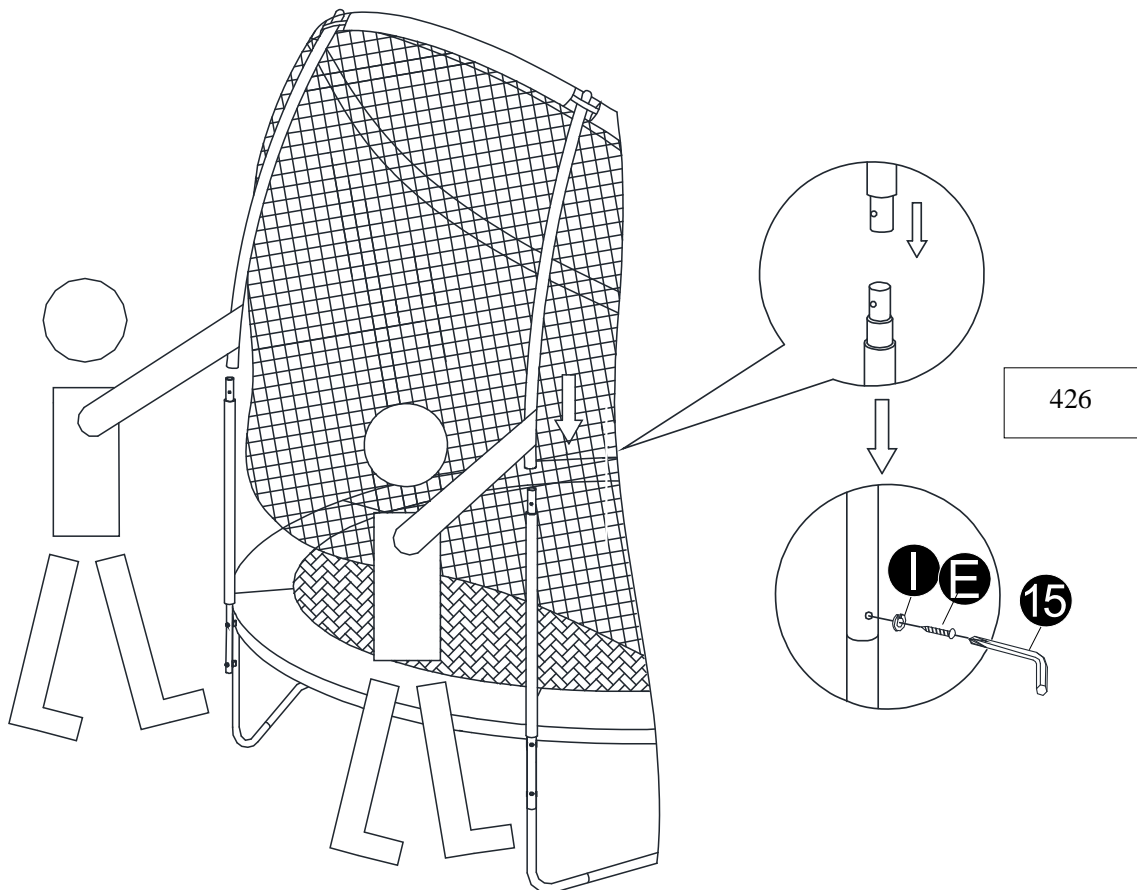
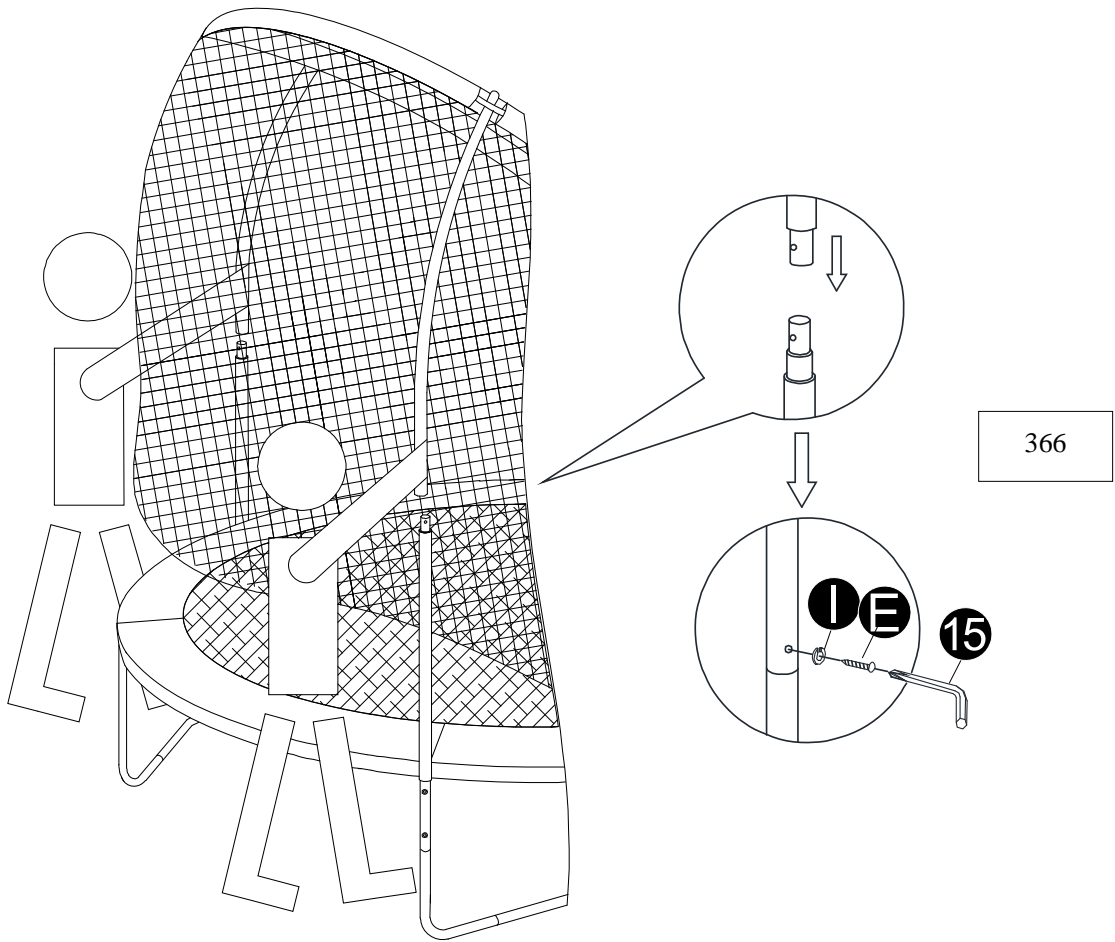

Trin 10

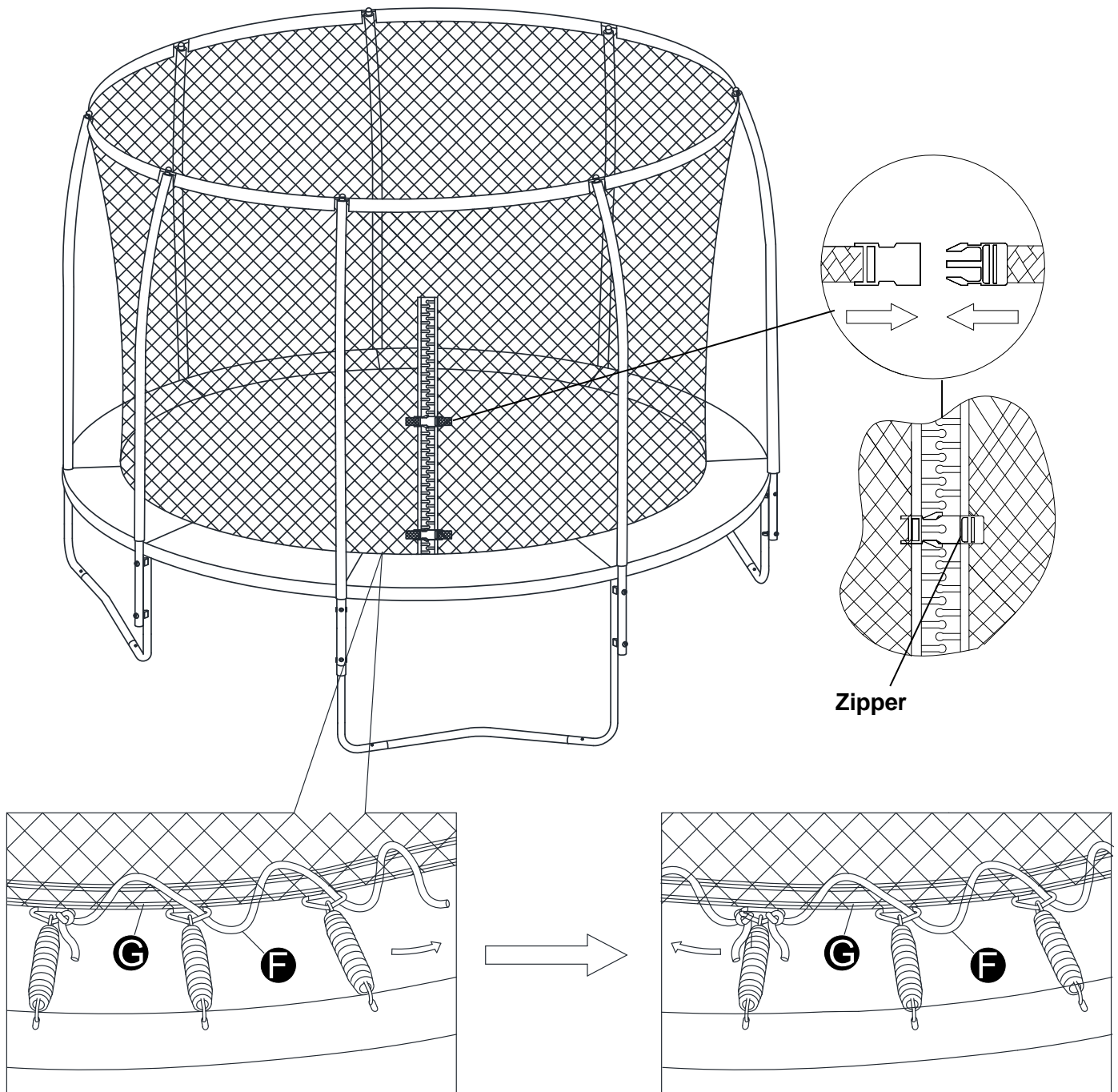

Trin 11

Vigtigt: Husk at stramme alle skruer, møtrikker og spænder på både trampolin og sikkerhedsnet.
Hvis ikke dette gøres, kan det ske, at den ikke fungerer korrekt, hvilket kan føre til skader, der ellers kunne have været undgået.

Trampolinen er nu færdigmonteret. Husk at være forsigtig, når du hopper.

GRUNDLÆGGENDE TRAMPOLINHOP

GRUNDLÆGGENDE HOP

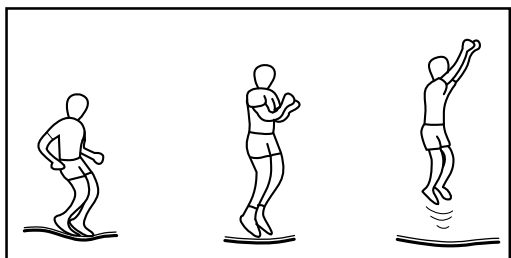

1. Start fra oprejst position, stå med spredte ben og hovedet oppe og med øjnene på trampolindugen.
2. Sving armene fremad og op og rundt i en cirkulær bevægelse.
3. Saml fødderne, når du er oppe i luften, og lad dine tæer vende nedad.
4. Hold fødderne fra hinanden, når du lander på dugen.

HOP PÅ KNÆ

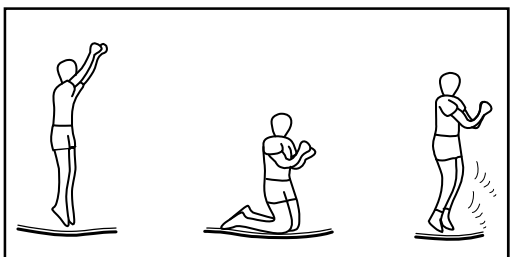

1. Start med lave basishop.
2. Land på knæene, samtidig med at du holder ryggen lige og kroppen strakt, og brug dine arme til at holde balancen.
3. Hop basishop igen ved at svinge armene opad.

HOP PÅ NUMSEN

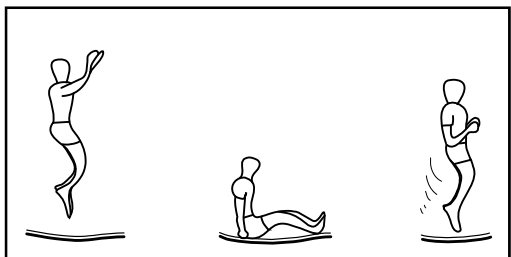

1. Land i siddende stilling.
2. Anbring hænderne på dugen ud for hofterne, lås ikke dine albuer.
3. Hop tilbage til oprejst stilling, skub fra med hænderne.

FORLÆNS HOP

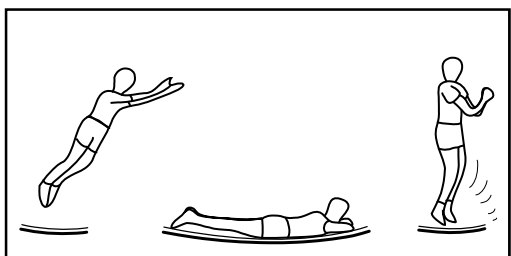

1. Start med at hoppe lavt.
2. Land liggende udstrakt på maven, og hold hænder og arme fremad på dugen.
3. Skub fra på dugen med armene for at returnere til stående stilling.

180-GRADERS HOP

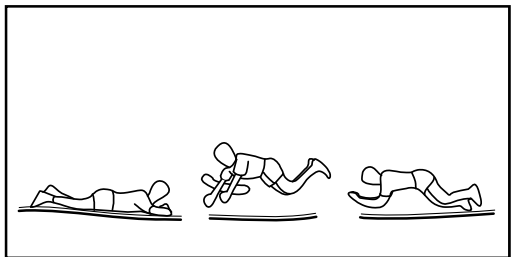

1. Start med at hoppe forlæns.
2. Skub fra med venstre eller højre hånd og arme (afhængigt af, hvilken vej du ønsker at dreje).
3. Hold hoved og skuldre i samme retning, og hold din ryg parallelt med dugen og hovedet oppe.
4. Land liggende udstrakt på maven, og returnér til stående position ved at skubbe opad med hænder og arme.

ADVARSEL!

BEGYND ALTID MED AT HOPPE PÅ MIDTEN AF DUGEN. HVIS DU LANDER MERE END 30 CM FRA LOGOET, SKAL DU STRAKS STOPPE!
BEGYND AT HOPPE IGEN PÅ MIDTEN AF DUGEN.

BEMÆRK

SØRG FOR, AT ALLE SPÆNDER OG LYNLÅSE ER LUKKET KORREKT, NÅR TRAMPOLINEN BRUGES.

PLEJE OG VEDLIGEHOLDELSE

Trampolinen er designet og fremstillet af kvalitetsmaterialer og udsøgt håndværk. Ved korrekt vedligeholdelse vil den give brugerne mange års træning, sjov og glæde, samtidig med at risikoen for skader vil være mindre. Følg vejledningen nedenfor. Montering af yderligere tilbehør bør ske i henhold til leverandørens vejledning.

Trampolinen er designet til at kunne tåle en bestemt vægt og belastning. Sørg for, at kun én person bruger trampolinen ad gangen. Brugere bør enten bruge strømper, gymnastiksko eller hoppe i bare fødder, når de bruger trampolinen. Udendørssko eller sportssko bør IKKE bæres, når trampolinen bruges. For at undgå beskadigelse eller huller i trampolindugen bør kæledyr ikke træde på dugen. Brugere skal også fjerne skarpe genstande, som de måtte have på sig, før de bruger trampolinen. Der bør ikke medtages nogen former for skarpe eller spidse genstande, når trampolinen bruges. Tjek med jævne mellemrum, at skruer, møtrikker og bolte er strammet godt, da de vil løsne sig under brug. Sørg for, at alle fjederbelastede samlinger (fjederpinde) er intakte og ikke kan løsne sig under brug. Tjek alle beskyttelsesdele for skarpe kanter, og erstæt dem, hvis det er nødvendigt. Sørg for, at dug, skumkanter og tilbehør ikke er defekte.

Undersøg altid trampolinen for slitage, forkert brug eller manglende dele før brug. Der kan opstå en række situationer, der kan øge din risiko for at komme til skade. Vær opmærksom på:

- revner eller huller i trampolindugen
- sunket trampolindug
- løse sting eller andre former for ødelæggelse af dugen
- bukkede eller knækkede rammedele, f.eks. på trampolinens ben
- ødelagte, manglende eller beskadigede fjedre
- ødelagte, manglende eller forkert monteret sikkerhedsbetræk
- fremspring af enhver art (især skarpe) på rammen, fjedre eller dugen

Bemærk. Sol, regn, sne og ekstreme temperaturer nedsætter delenes holdbarhed.

HVIS DU MENER, AT DISSE FORHOLD ELLER ANDET KUNNE FORÅRSAGE PERSONSKADE FOR BRUGERNE, BØR TRAMPOLINEN SKILLES AD ELLER SIKRES MOD BRUG, INDTIL FEJLEN(E) ER BLEVET UDBEDRET.

Foretag ikke ændringer af trampolinen eller nogen af delene

Af sikkerhedshensyn bør sikkerhedsnettet udskiftes hvert år

FLYTNING AF TRAMPOLINEN

Det kræver to personer at flytte trampolinen. Alle fæstningspunkter bør være sikret med vejrbestandig tape, såsom klæbetape. Dette vil holde rammen intakt, når den flyttes, og forhindre, at fastgørelsespunkterne ikke flytter sig eller går løs. Løft trampolinen lidt fra jorden for at flytte den, og hold den vandret med jorden. Trampolinen bør skilles ad ved al anden form for flytning.

Gem denne vejledning.

Produceret af Crowntec(Jiang Xi)Sports Technology Co,Ltd,
Intersection of West Blvd. and Jingyi Road, Gongqingcheng City, Jiujiang City, Jiangxi Province,China.
office@crowntecgroup.com

Importeret af Salling Group, Rosbjergvej 33, 8220 Brabrand.
sallinggroup.com